

A Bug's Life: Integration of Anaerobic Digestion and Bioelectrochemical Systems for Enhanced
Energy Recovery from Wastewater Solids and Other Waste Substrates

A Thesis Presented for the
Master of Science
Degree
The University of Tennessee, Knoxville

Jeff Ryan Beegle
May 2017

Notice of Copyright

This manuscript has been co-authored by UT-Battelle, LLC under Contract No. DE-AC05-00OR22725 with the U.S. Department of Energy. The United States Government retains and the publisher, by accepting the article for publication, acknowledges that the United States Government retains a non-exclusive, paid-up, irrevocable, world-wide license to publish or reproduce the published form of this manuscript, or allow others to do so, for United States Government purposes. The Department of Energy will provide public access to these results of federally sponsored research in accordance with the DOE Public Access Plan (<http://energy.gov/downloads/doe-public-access-plan>).

This thesis is dedicated to everyone who helped me get to this point, especially Jayde, Amy, Kevin, Peter, Heather, and Schrodinger

Acknowledgements

First, I want to thank everyone who helped me at the University of Tennessee and Oak Ridge National Laboratory. Lee, Scott, Mike, Ian, Wanda, and all of the others in the Bredesen Center for making UT and ORNL a part of my life journey. The Microbiology Department for accepting me as a Master's Candidate to complete my thesis. Abhijeet, for taking me in as a graduate student and helping me through the challenges of balancing research, life, and entrepreneurial pursuits. Terry and Erik serving on my thesis committee and helping to conclude this chapter in my academic career. For the numerous researchers, students, and interns that helped me with my research: Miguel R., Alex L., Scott S., Michelle H., Jessica V., Kannaiah R., Tim M., Danni L., Weng L., Johan A., Nathan R., Parker D., Victoria B., Kailey P. And to everyone who has helped with my entrepreneurship ventures, classes, or some other aspect of graduate school: Jayde A., Tony B., Mallory L., Ben M., Chelsea D., Robbie B., Beth C., Rob M., and Patrick C.

Lastly, I want to thank the people that have supported me since the idea of graduate school was just beginning to form in my head: Amy B., Kevin B., Peter B., Heather B., Joe C., Stacie A., Ron A., Maddie A., Dom S., Michael J., Alan M., Kyle M., Nathan R., Zach R., Meri M., Julie C., Erin L., David L., Beth H., Gwen B., and Tommy B. Thank you to all of my teachers and mentors from Hudson, the University of Toledo, and the University of Tennessee. A special thanks to Dr. Sanjay Khare for sparking my interest in sustainability and launching me in this direction.

Abstract

Organic waste streams, like domestic wastewater and municipal solid waste, have the potential to be used as feedstocks for biotechnology processes to produce high value products and energy. This thesis investigated the technological, economical, and environmental potential for integrated anaerobic digestion (AD) and bioelectrochemical system (BES) platforms as they were theoretically and physically evaluated for energy recovery from domestic wastewater. The first chapter of this thesis compared the theoretical energy efficiencies of converting waste directly into electricity, using AD and BES alone and in various combinations. This chapter reviewed the experimentally demonstrated energy efficiencies reported in the literature with comparisons to the maximum theoretical efficiencies, considering thermodynamic limits. Acetate was used as an ideal substrate for theoretical calculations, whereas complex wastes were used for extended analyses of practical efficiencies. In addition, to address the potential economic and environmental benefits of this technology, a brief case study was investigated using the Oak Ridge National Laboratory (ORNL) water resource recovery facility (WRRF). This work identified a combined Anaerobic Digestion/Microbial Electrolysis Cell (ADMEC) platform as the most viable treatment process for further study. In the second chapter, the abovementioned ADMEC system was tested using real domestic wastewater from the ORNL WRRF. The system was modified to include two pretreatment methods, alkaline and thermal hydrolysis, to observe potential effects of pretreatment on energy recovery. The systems in chapter two were operated so that hydrogen recovery was maximized, at the expense of biogas recovery. The results from this chapter indicated that thermal hydrolysis pretreatment had the greatest positive effect on methane composition and hydrogen production, while also reducing overall biogas production. Alkaline pretreatment had a net-negative impact on energy recovery compared to the control. This thesis concludes with my personal reflection on these technologies and where I think they may play a role in the future.

Table of Contents

Thesis Introduction	1
Chapter 1: Energy Production from Waste: Evaluation of Anaerobic Digestion and Bioelectrochemical Systems based on Energy Efficiency, Economic, and Environmental Factors	5
Literature Review	5
Scientific Methods	7
<i>Calculation of Energy Efficiencies</i>	7
<i>Calculation of Theoretical Energy Efficiencies using Acetate</i>	8
<i>Calculation of Practical Energy Efficiencies using Acetate</i>	11
<i>Calculation of Practical Energy Efficiencies using Complex Wastes</i>	13
<i>Economic and Environmental Analysis</i>	13
<i>Energy Efficiencies</i>	14
<i>Economic Benefit</i>	15
<i>Environmental Benefits</i>	16
Discussion	17
Conclusions	20
Acknowledgements:	20
Chapter 2: A New Perspective on Wastewater Energy Recovery Using Bioelectrochemical Systems and Anaerobic Digestion	21
Literature Review	21
Scientific Methods	22
<i>Wastewater Collection and Fractionation</i>	22
<i>Pretreatment Protocol</i>	23
<i>Anaerobic Digester Setup and Operation</i>	23
<i>Microbial Electrolysis Cell Start-Up & Operation</i>	24
<i>Analysis and Calculations</i>	25
Results	27
<i>Effects of Pretreatment on Soluble COD</i>	27
<i>Influence of Pretreated Sludge on Anaerobic Digestion</i>	28
<i>Effects of Pretreatment in MECs</i>	31
<i>COD-electron Balance</i>	34
<i>Energy Production from ADMFC Systems</i>	34
Discussion	38
Conclusions	40
Acknowledgements:	41
Personal Perspective	42
References	45
Appendix	59
Vita	76

List of Tables

Table 1. Anaerobic Digester biogas yields from various waste sources	2
Table 2. Summary of Food Waste and Wastewater Energy Content and Energy Recovery	6
Table 3. Literature Review of Selected Technologies	12
Table 4. Net Present Value of Case Study	16
Table 5. Sludge Characteristics Before and After Pretreatment	24
Table 6. Proximate and Energy Analysis of Food Waste (Modified from Tchobanoglous 1993)	62
Table 7. Theoretical Energy Recovery from Acetate	63
Table 8. Practical Energy Recovery from Acetate	64
Table 9. Practical Energy Recovery from Food Waste	64
Table 10. Practical Energy Recovery from Sewage Sludge	65
Table 11. One-Kilogram Analysis of Food Waste and Wastewater Solids	65
Table 12. Summary of Economic Model Variables	66
Table 13. Net-Present Value for AD Process	67
Table 14. Net-Present Value for MFC Process	68
Table 15. Net-Present Value for MEC Process	69
Table 16. Net-Present Value for ADMFC Process	70
Table 17. Net-Present Value for ADMEC Process	71
Table 18. Carbon Intensity of Fuel Sources	72
Table 19. ADMEC Experiment Data for COD Balance	74
Table 20. COD Balance Summary	74
Table 21. Energy Production Summary	75

List of Figures

Figure 1. OMC and Mtr Pathways in *Geobacter sulfurreducens* and *Shewanella oneidensis*. Adapted from Kracke et al 2015. Solid arrows indicate experimentally proven pathways and dotted arrows indicate hypothetical pathways. _____ 4

Figure 2. Schematic of a Microbial Fuel Cell (Left) and a Microbial Electrolysis Cell (Right) _ 7

Figure 3. Configurations of waste to energy systems. ADMFC (Red) combines an AD with a downstream MFC. AD (Blue) uses only digestion. ADMEC (Green) combines an AD with a downstream MEC. MEC (Orange) and MFC (Black) use only microbial fuel cells or microbial electrolysis, respectively. All systems ultimately generate electricity. _____ 9

Figure 4. Comparison of energy efficiencies for waste conversion processes. _____ 15

Figure 5. Offset Carbon Dioxide Equivalent Emissions by Source. Reported in billion kg CO₂-equivalent. All values are reported in billion kg CO₂-equivalent. The plot shows emissions from offset energy demand for aerobic water treatment (Blue) and the offset emissions from renewable energy generation from sludge (Red). _____ 17

Figure 6. Schematic of combined ADMEC System with Pretreatment Stage. Raw wastewater was concentrated to 1% TS and pretreated. The soluble and insoluble fractions were separated and fed into subsequent biological reactors. _____ 23

Figure 7. Microbial Electrolysis Cell Set-up _____ 25

Figure 8. Effects of Alkaline and Thermal Hydrolysis Pretreatment on soluble COD in laboratory 1-L tests _____ 28

Figure 9. Effect of Sludge Pretreatment on Methane Composition _____ 29

Figure 10. Specific methane production for Anaerobic Digesters _____ 30

Figure 11. Organic Acid Profile in Digester Effluent during Startup _____ 30

Figure 12. Hydrogen production rates in MECs fed with AD effluent and Control Runs. ACE and Propionate groups are control runs with 0.2 gCOD-eq/L. _____ 31

Figure 13. Reactor performances in MECs fed with AD effluent. CE, CCE, and HE are Coulombic Efficiency, Cathode Conversion Efficiency, and Hydrogen Efficiency, respectively _____ 32

Figure 14. Hydrogen production rates in MECs fed with PT effluent. ACE and Propionate groups are control runs with 0.2 gCOD-eq/L _____ 33

Figure 15. Reactor performances in MECs fed with PT effluent. CE, CCE, and HE are Coulombic Efficiency, Cathode Conversion Efficiency, and Hydrogen Efficiency, respectively _____ 33

Figure 16. COD Balance for Control, Alkaline, and Thermal Experiment Groups _____ 36

Figure 17. Energy Produced per gram of COD added per day. Energy from methane during anaerobic digestion (Green), hydrogen gas from pretreatment effluent (Blue), and hydrogen gas from digester effluent (Yellow). _____ 37

Figure 18. Steps of Anaerobic Digestion (Modified from Li 2011) _____ 62

Figure 19. Schematic of Basic Fuel Cell Design _____ 63

Figure 20. Effects of Alkaline and Thermal Hydrolysis Pretreatment on soluble COD in small-scale preliminary tests _____ 72

Figure 21. Electrochemical Data from MEC Experiments. Top Row: Pretreatment Soluble Phase (Control, Alkaline, and Thermal), Middle Row: Anaerobic Digester Effluent (Control, Alkaline, and Thermal). Bottom Row: Acetate and Propionate Controls _____ 73

List of Abbreviations and Symbols

A/mA:	Ampere/milli-ampere, unit of current
AD:	Anaerobic Digestion
ADMEC:	Anaerobic Digestion & Microbial Electrolysis Cell
ADMFC:	Anaerobic Digestion & Microbial Fuel Cell
AnMBR:	Anaerobic Membrane Bioreactor
ABS:	Absorbance, used in COD analysis
AOP:	Advanced Oxidation Process
BES:	Bioelectrochemical System
BOD:	Biochemical Oxygen Demand
CE:	Coulombic Efficiency
CCE:	Cathode Conversion Efficiency
CH ₄ :	Methane (gas)
COD:	Chemical Oxygen Demand
CO:	Carbon Monoxide (gas)
CO ₂ /CO ₂ -eq:	Carbon Dioxide / Carbon Dioxide equivalent for gas emissions
°C:	Celsius, temperature
CWA:	Clean Water Act
CWSRF:	Clean Water State Revolving Fund
d:	day, time
E _x :	Energy, for a particular process x
η _x :	Eta, energy efficiency for a particular process x
g:	gram, unit of mass
H ₂ :	Hydrogen (gas)
HE:	Hydrogen Efficiency
HRT:	Hydraulic Residence Time
H ₂ SO ₄ :	Sulfuric Acid
I _x :	Current, for a particular process x
IBR:	Integrated Biorefinery
kWh:	Kilowatt-Hour, unit of energy
L:	Liter, unit of volume
LCA:	Life Cycle Analysis
MBR:	Membrane Bioreactor
MEC:	Microbial Electrolysis Cell
MFC:	Microbial Fuel Cell
MGD:	Million Gallon per Day
MSW:	Municipal Solid Waste
N ₂ :	Nitrogen (gas)
NaCl:	Sodium Chloride
NaOH:	Sodium Hydroxide
NPV:	Net Present Value

O ₂ :	Oxygen (gas)
OLR:	Organic Loading Rate
ORNL:	Oak Ridge National Laboratory
O&M:	Operation and Maintenance cost
Ω:	Omega, electrical resistance
PEMFC:	Proton exchange membrane fuel cell
PPP:	Public-Private Partnership
PT:	Pretreatment
TS:	Total Solids
UV:	Ultraviolet (light)
V _x :	Voltage, for particular process x
VFA:	Volatile Fatty Acid
VS:	Volatile Solids
WEPA:	Water-Energy Purchase Agreement
WRRF:	Water resource recovery facility
WW:	Wastewater
WWTP:	Wastewater Treatment Plant
Y _{H₂} :	Hydrogen Yield

List of Equations

Eq. 1	$IMFC = 118.60 A$	8
Eq. 2	$VMFC = V_{cat} - V_{an} = 1.10 V$	8
Eq. 3	$EMFC = IMFC * VMFC * 24hr(1000W1kW) = 3.14 kWh$	8
Eq. 4	$E_{Acetate} = 3.78 kWh$	8
Eq. 5	$\eta_{MFC} = EMFC/E_{acetate} = 82.98\% \text{ efficiency}$	8
Eq. 6	$IMEC = 118.60 A$	10
Eq. 7	$Y_{H_2} = 1.19 m^3H_2$	10
Eq. 8	$V_{MEC} = V_{cat} - V_{an} = -0.14 V = V_{app}$	10
Eq. 9	$EMEC = Y_{H_2} * 3.29kWhm^3H_2 * 83\% PEMFC_{eff} = 3.25 kWh$	10
Eq. 10	$E_{app} = V_{app} * IMEC * 24hr1000W1kW = -0.39 kWh$	10
Eq. 11	$\eta_{MEC} = EMEC/E_{acetate} + E_{app} = 78.01\%$	10
Eq. 12	$Y_{CH_4} = 0.34m^3day$	10
Eq. 13	$EAD = 1.34 kWh$	10
Eq. 14	$\eta_{AD} = EAD/E_{acetate} = 35.39\%$	10
Eq. 15	$EAD' = EAD * 80\% \text{ removal} = 1.07 kWh$	11
Eq. 16	$IMFC' = IMFC * 20\% = 23.72 A$	11
Eq. 17	$EMFC' = IMFC' * VMFC * 24hr1000W1kW = 0.63 kWh$	11
Eq. 18	$\eta_{ADMFC} = EAD' + EMFC'E_{acetate} = 44.89\% \text{ efficiency}$	11
Eq. 19	$IMEC' = IMEC * 20\% = 23.72 A$	11
Eq. 20	$Y_{H_2}' = Y_{H_2} * 20\% = 0.24m^3H_2day$	11
Eq. 21	$EMEC' = Y_{H_2}' * 3.29kWhm^3H_2 * 83\% PEMFC = 0.65 kWh$	11
Eq. 22	$E_{app}' = V_{app} * IMEC' * 24hr1000W1kW = -0.08 kWh$	11
Eq. 23	$\eta_{ADMEC} = EAD' + EMEC'E_{acetate} + E_{app}' = 44.58\%$	11
Eq. 24	$CT = \text{Cash Flow} = Rev - O\&M(1 + r)^t$	13
Eq. 25	$NPV = \sum_{t=1}^n \frac{CT_t}{(1+r)^t} - C_0$	14
Eq. 26	$\text{Specific Methane Yield} = mL CH_4/gCOD * day$	26
Eq. 27	$\text{Coulombic Efficiency} = I_{obs} * t_{meas} * \eta_e F$	26
Eq. 28	$\text{Cathode Conversion Efficiency} = P * V_{H_2R} * T_{Cobs} F * \eta_e$	26
Eq. 29	$\text{Hydrogen Efficiency} = P * V_{H_2R} * T_2 * \eta_t$	26
Eq. 30	$\text{Hydrogen Production Rate} = V_{H_2} Vol_{anode} * time$	26
Eq. 31	$COD \text{ solubilization} = sCOD - sCOD_0(TCOD_0 - sCOD_0)$	26
Eq. 32	$IMFC = 1000gCODL * Day * 85\% \text{ biomass} * mol_{32gCOD} * 4e - mol * 96485 \text{ Coloumbe} * 1day86400seconds = 118.6 A$	60
Eq. 33	$\Delta G_{an}' = 2HCO_3^- + 9H^+ + 8e^- \rightarrow CH_3COO^- + 4H_2O = -144.34 kJ/mol$	60
Eq. 34	$V_{an}' = -\Delta G_{an}' / 8 * 96485 = 0.187 V$	60
Eq. 35	$V_{an} = V_{an}' - RT/8F \ln \frac{CH_3COO^-}{[HCO_3^-]^2 H^+ + 9} = -0.296V$	60
Eq. 36	$\Delta G_{cat}' = O_2 + 4H^+ + 4e^- \rightarrow 2H_2O = -474.3 kJ/mol$	60
Eq. 37	$V_{cat}' = -\Delta G_{cat}' / 4 * 96485 = 1.229 V$	60
Eq. 38	$V_{cat} = V_{cat}' - RT/4F \ln \frac{1}{pO_2 H^+ + 4} = 0.805 V$	60
Eq. 39	$VMFC = V_{cat} - V_{an} = 1.101 V$	60
Eq. 40	$EMFC = IMFC * VMFC * 24hr(1000W1kW) = 3.135 kWh$	60
Eq. 41	$E_{Acetate} = 3.778 kWh$	60

Eq. 42	$\eta_{MFC} = EMFCE_{acetate} = 82.98\%$ efficiency	60
Eq. 43	$IMEC = 118.6 A$	60
Eq. 44	$Y_{H_2} = 1.192 m^3 H_2$	60
Eq. 45	$\Delta G_{an}' = 2HCO_3^- + 9H^+ + 8e^- \rightarrow CH_3COO^- + 4H_2O = -144.34 kJ/mol$	60
Eq. 46	$V_{an}' = -\Delta G_{an}' / 8 * 96485 = 0.187 V$	61
Eq. 47	$V_{an} = V_{an}' - RT/8 \ln CH_3COO^- / [HCO_3^-]_{2H^+ + 9} = -0.276V$	61
Eq. 48	$\Delta G_{cat}' = 2H^+ + 2e^- \rightarrow H_2 = 0 kJ/mol$	61
Eq. 49	$V_{cat}' = -\Delta G_{cat}' / 2 * 96485 = 0V$	61
Eq. 50	$V_{cat} = V_{cat}' - RT/2 \ln p_{H_2} / 2 = -0.414 V$	61
Eq. 51	$V_{MEC} = V_{cat} - V_{an} = -0.138 V = V_{app}$	61
Eq. 52	$EMEC = Y_{H_2} * 3.29 kWh / m^3 H_2 * 83\% PEMFC = 3.25 kWh$	61
Eq. 53	$E_{app} = V_{app} * IMEC * 24hr / 1000W = -0.39 kWh$	61
Eq. 54	$\eta_{MEC} = EMECE_{acetate} + E_{app} = 78.01\%$	61
Eq. 55	$Y_{CH_4} = 1,000 gCOD/day * 88\% current * 1 mol CH_4 / 64 gCOD * 16.04 gCH_4 / mol CH_4 * 1 LCH_4 / 0.656 gCH_4 * 1 m^3 CH_4 / 1000 LCH_4 = 0.34 m^3/day$	61
Eq. 56	$EAD = 0.34 m^3/day * 10.35 kWh / m^3 * 38\% efficiency * 1 day = 1.337 kWh$	61
Eq. 57	$\eta_{AD} = EAD / E_{app} = 35.39\%$	61

Thesis Introduction

Human activity and the consumption of fossil fuels has led to increased greenhouse gas emissions, resulting in warming the oceans and the atmosphere, significantly reducing snow and ice cover globally, and rising sea levels (Allen, Barros, Broome, & Cramer, 2014). Anthropogenic impacts on human and natural systems are clear. The strong global dependence on fossil fuels for energy generation and industrial activity and the sensitive relationship between water and energy requires new energy technologies to perform at high standards while utilizing natural resources in an environmentally and socially responsible way (Hussey & Pittock, 2012). In the US, fossil fuels provide 82% of the primary energy supply, however organic waste materials like, food wastes, sewage sludges and other wastes represent an unutilized renewable feedstock for the production of electricity, hydrogen gas, biomethane, and biochemicals that can be used to offset fossil fuel demand (Association Energy Information, 2012; Logan, Verstraete, & Rabaey, 2006; Lovley, 2006; Weiland, 2010; Zhang & Angelidaki, 2014).

Thermochemical technologies, like pyrolysis, gasification, combustion, and torrefaction, represent one path toward the utilization of waste for energy generation (Acharya, Dutta, & Minaret, 2015; Cao & Pawłowski, 2012; Malkow, 2004; Yuan, Wang, Kobayashi, Zhao, & Xing, 2015). However, these technologies typically operate at low efficiencies due to the high moisture content of the waste (Oh et al., 2010; Scherson & Criddle, 2014). In addition, these technologies ineffectively utilize the components of waste streams that have the potential to be transformed into high-value products and instead generate chars, tars and, oils, although these products are beginning to be investigated as useful waste streams (A. J. Lewis et al., 2015; Alex J. Lewis & Borole, 2016; Weaver et al., 2016). There are also environmental concerns with gaseous pollutants released during incineration processes, like dioxins (Appels et al., 2011).

In contrast, biological systems utilize the capabilities of highly specialized bacteria, archaea, and single-cell eukaryotes to convert waste streams into a wide range of products, often while simultaneously performing beneficial remediation or treatment services. Bacteria are essential for nutrient recycling and remediation in natural systems like soils and oceans (Atlas & Hazen, 2011; Schimel & Schaeffer, 2012; Zehr & Ward, 2002). Ancient cultures realized the potential for harnessing the power of bacteria and other microbes and started using yeast to ferment wines, dating back to at least 3,100 B.C. (Cavaliere, McGovern, Hartl, Mortimer, & Polsinelli, 2003). In modern times, microbes have been harnessed for industrial processes, such as producing valuable biochemicals like, fuels, polymers, amino acids, vitamins, and pharmaceuticals. (Demain, 2000; Harnisch, Rosa, Kracke, Viridis, & Krömer, 2015; Marshall, Labelle, & May, 2013; Paddon & Keasling, 2014). Many of these processes are highly controlled, using monocultures of engineered strains in optimized reactors, and highly regulated, requiring simple, cheap substrates to generate products with little variation.

Anaerobic digestion is a biological process facilitated by a diverse microbial community that can breakdown and convert macromolecules in waste into biogas, nutrient rich sludge, and short chain fatty acids. The composition of biogas contains 50-70% methane, 30-40% carbon dioxide, and other trace gases, like hydrogen sulfide, hydrogen, nitrogen, and siloxanes (USDA, EPA, & DOE, 2014). The anaerobic digestion (AD) process is divided into 3 essential steps (see Figure 18): hydrolysis, acidogenesis/acetogenesis and methanogenesis (Merlino et al., 2013). During the initial hydrolysis step, microbes secrete hydrolytic enzymes, like cellulase, cellobiase, xylanase, amylase, lipase, and protease, to degrade biopolymers (Weiland, 2010). The resulting compounds are fermented into alcohols and fatty acids, like acetate and ethanol. Strict anaerobes

from the genera *Bacteriocides*, *Clostridia*, and *Bifidobacteria*, as well as facultative anaerobes from the genera *Streptococci* and *Enterobacteriaceae*, are involved in most of the hydrolysis and fermentation steps (Weiland, 2010). Acetate is the preferred substrate for acetogenic methanogens, of the genera *Methanosarcina* and *Methanosaeta*, which account for roughly two-thirds of the methane production in an anaerobic digester when using acetate as a substrate (Y. Liu & Whitman, 2008; Zinder, 1993). Carbon dioxide and methylated compounds are alternative substrates for methane production. Carbon dioxide is suitable for *Methanothermobacter*, *Methanosarcina*, and other hydrogenotrophic methanogens and methylated compounds are suitable for *Methanosarcina*, *Methanosphaera*, and other methylotrophic methanogens (Y. Liu & Whitman, 2008). The biogas generated from digestion contains between 65-70% methane and 30-35% carbon dioxide, in general (Appels et al., 2011). Methane produced during AD can be converted into electricity and heat, which can be used to offset energy use in industrial facilities like water resource recovery facilities (WRRFs). Table 1 presents a summary of biogas yields from various sources of biomass and organic waste streams. Although anaerobic digestion is considered a mature technology, there are several barriers preventing widespread adoption in the U.S., including large capital costs, high annual O&M costs, risk of system failure, and lack of outside support (Willis et al., 2012). Many of these risks stem from the long residence times and large footprints required for conversion and treatment. In recent decades, feedstock pretreatment steps have been added to accelerate the hydrolysis step, which is often the rate-limiting step, resulting in improved energy recovery, sludge biodegradability, biogas composition, and sludge stabilization (Ariunbaatar, Panico, Esposito, Pirozzi, & Lens, 2014; Bordeleau & Droste, 2011; Carrère et al., 2010; Penaud, Delgenès, & Moletta, 1999; Yu et al., 2014).

Table 1. Anaerobic Digester biogas yields from various waste sources

Substrate	Co-Substrate	Biogas (l/g VS fed)	Reactor Configuration	Reference
Cow Manure	Agriculture Waste	0.62	Continuous-Stirred Tank Reactor (CSTR)	(Cavinato, Fatone, Bolzonella, & Pavan, 2010)
Fruit and Vegetable Waste	Wastewater	0.51	Anaerobic Sequencing Batch Reactor (ASBR)	(Bouallagui, Lahdheb, & Romdan, 2009)
Municipal Solid Waste (MSW)	Fats, Oil and Grease (FOG)	0.55	Fed-Batch Reactor	(Martín-González, Colturato, Font, & Vicent, 2010)
Primary Sludge	Fruit and Vegetable Waste	0.40	Continuous-Stirred Tank Reactor (CSTR)	(Gómez, Cuetos, Cara, Morán, & García, 2006)
Sewage Sludge	Municipal Solid Waste	0.60 *	Semi-UASB	(Sosnowski, Wieczorek, & Ledakowicz, 2003)
Food Waste		0.32	Continuous-Stirred Tank Reactor (CSTR)	(X. Chen, Romano, & Zhang, 2010)

* VSS added

In the last century, Potter discovered the biological phenomena that the oxidation of organic matter by bacteria led to the formation of an electrical potential difference in an electrochemical reactor (Potter, 1911, 1915). This initial study has been investigated and modified to harvest and control the products of redox reactions in these bioelectrochemical systems (BES). It is now known that several bacteria can use inorganic terminal electron acceptors in their environment. The applications for this phenomena are widespread, spanning from electricity, hydrogen production and electrofermentation, to bioremediation and biosensors

(Call & Logan, 2008; Gregory & Lovley, 2005; Harnisch et al., 2015; Logan et al., 2006; Roman Moscoviz, Toledo-Alarcón, Trably, & Bernet, n.d.; Venkata Mohan, Velvizhi, Vamshi Krishna, & Lenin Babu, 2014). The potential value of BES is that the bioelectrochemical reactions occur at higher energy efficiencies than other electrochemical reactions. For instance, typical water electrolyzers require an applied voltage of 1.8-2 V to produce hydrogen gas, whereas the theoretical applied voltage for hydrogen production in a microbial electrolysis cells is 0.14 V (Call & Logan, 2008; H. Cheng, Scott, & Ramshaw, 2002).

The organisms initially identified by Potter that are responsible for extracellular electron transport to inorganic electron acceptors are known as electrogens, also known as electroactive microorganisms or electroactive bacteria. There are three known mechanisms of extracellular electron transport: transfer by electron mediators or shuttles, direct membrane electron transfer, and microbial nanowires (Logan et al., 2006; Malvankar & Lovley, 2014; Strycharz-Glaven, Snider, Guiseppi-Elie, & Tender, 2011). There are other methods of interspecies electron transfer that play pivotal roles in microbial communities (Batstone & Viridis, 2014; Malvankar & Lovley, 2014). It has been demonstrated that organisms like *E. coli* and *P. aeruginosa* are capable of secreting hydroquinone derivatives and phenazine derivatives, respectively, which act as electron mediators in their environment (Qiao, Li, Bao, Lu, & Hong, 2008; Rabaey, Boon, Höfte, & Verstraete, 2005). Gram negative bacteria like *G. sulfurreducens* and *S. oneidensis* have been documented to transport electrons directly to inorganic electron acceptors (Kracke, Vassilev, & Krömer, 2015). Figure 1 illustrates the OMC and Mtr Pathways for electron transport to inorganic electronic acceptors in some gram negative species. (Kracke et al., 2015). There are also proposed mechanisms for electron transport in gram positive bacteria. In acetogenic organisms like *M. thermoacetica*, there may be membrane cytochromes responsible for direct and shuttled electron transport but there may also be cytochrome-less transport mechanisms in organisms like *C. ljungdahii* and *A. woodii* (Kracke et al., 2015; Ljungdahl, Adams, Barton, Ferry, & Johnston, 2003; Müller, 2003). The organisms capable of producing conductive nanowires have demonstrated at least two mechanisms for electron transport. Microbes like *S. oneidensis* produce cytochrome-containing nanowires that are capable of “electron hopping” (El-Naggar et al., 2010; Gorby et al., 2006). Conversely, organisms like *G. sulfurreducens* produce type IV pili that exhibit conductive behavior due to overlapping pi orbitals in aromatic amino acid residues (Reguera et al., 2005). It should be noted that the effects of nanowires, interspecies electron transfer, and redox shuttles are relevant for AD and BES.

Bioelectrochemical systems rely on diverse microbial communities that extend beyond electrogens, alone. These systems are often enriched with glucose as a fermentable substrate, in addition to substrates like acetate to support the growth of electrogens. The role of microbes like fermenters and other syntrophes is to hydrolyze and ferment more complex substrates, like alcohols and longer organic acids (Borole & Mielenz, 2011; Freguia, Rabaey, Yuan, & Keller, 2008). This is increasingly important in bioelectrochemical systems fed with complex substrates like wastewater, anaerobic digester effluent, and other waste streams. The enrichment of fermenters improves the robustness of the microbial communities and improves the overall oxidation of substrates that cannot be consumed directly by electrogens (Miceli, Garcia-Pena, Parameswaran, Torres, & Krajmalnik-Brown, 2014). In addition, these robust communities may also work to mitigate the role of hydrogen scavengers and other detrimental microbes (Parameswaran, Zhang, Torres, Rittmann, & Krajmalnik-Brown, 2010).

The aim of this thesis is to investigate anaerobic digestion and bioelectrochemical systems as mutually beneficial technologies for the recovery of energy and other products from

waste, as proposed by Pham et al (T. H. Pham et al., 2006). The first chapter of this thesis investigates the theoretical and practical energy efficiencies of AD and BES systems based on ideal substrates, like acetate, and complex feedstocks, like domestic wastewater and municipal solid waste. The first chapter also investigates the expected economic and environmental impacts of integrated AD/BES platforms treating domestic wastewater at the Oak Ridge National Laboratory (ORNL) wastewater resource recovery facility (WRRF). The second chapter applies the findings of the first chapter to construct an integrated ADMEC system for wastewater treatment and energy recovery. The experiments performed in this chapter also including a pretreatment step to investigate mechanisms to enhance hydrogen production and accelerate rate-limiting conversion steps like hydrolysis. This thesis concludes with my personal reflection on these technologies and where I think they may play a role in the future, particularly focusing on technology commercialization, the state-of-the-art, and potential markets.

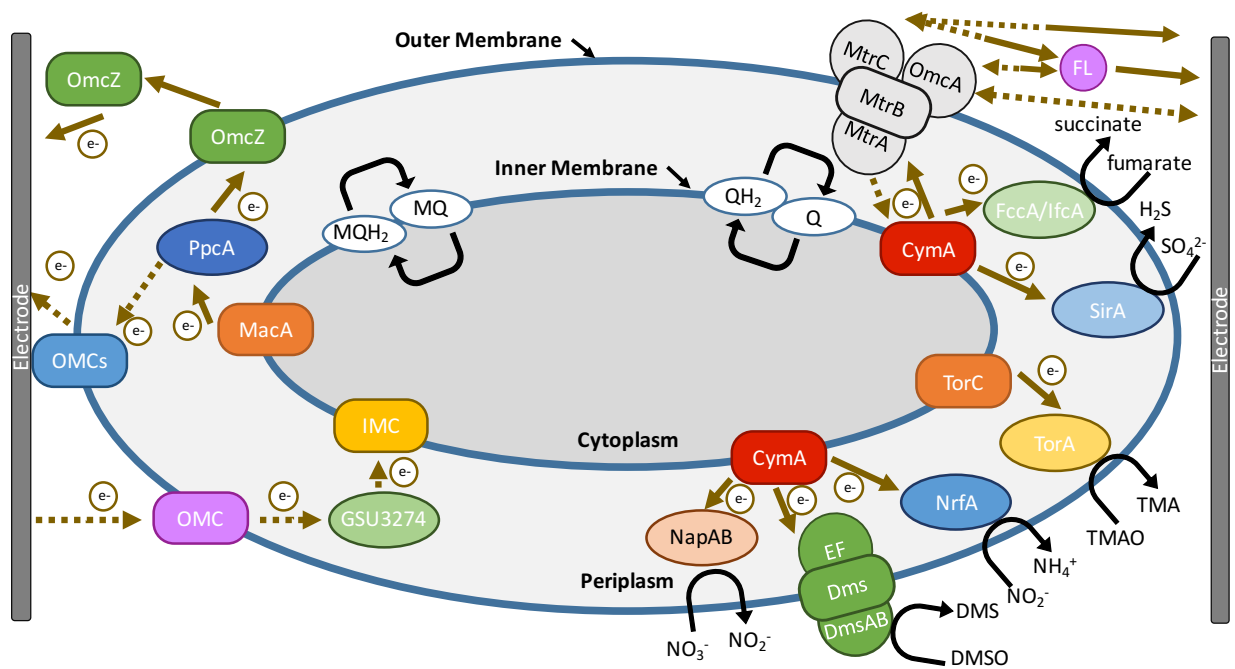

Figure 1. OMC and Mtr Pathways in *Geobacter sulfurreducens* and *Shewanella oneidensis*. Adapted from Kracke et al 2015. Solid arrows indicate experimentally proven pathways and dotted arrows indicate hypothetical pathways.

Chapter 1: Energy Production from Waste: Evaluation of Anaerobic Digestion and Bioelectrochemical Systems based on Energy Efficiency, Economic, and Environmental Factors

Authors: Jeff Beegle and Abhijeet Borole

Literature Review

The strong international dependence on fossil fuels for energy generation and the sensitive relationship between water and energy requires new energy technologies to perform at high standards while utilizing natural resources in an environmentally and socially responsible way (Hussey & Pittock, 2012). In the US, fossil fuels provide 82% of the primary energy supply, however food wastes, sewage sludges and other wastes represent an unutilized renewable feedstock for the production of electricity, hydrogen gas, biomethane, and biochemicals that can be used to offset fossil fuel demand (Association Energy Information, 2012; Logan et al., 2006; Lovley, 2006; Weiland, 2010; Zhang & Angelidaki, 2014). Municipal solid waste (MSW) is one potential energy source with over 60% containing organic material. The food waste fraction alone (14.6% of total MSW) is produced at a rate of 33.5 billion kilograms per year by individuals, with an additional 27 billion kilograms generated by retailers (Buzby, Wells, & Hyman, 2014; USEPA, 2014). In terms of chemical oxygen demand (COD), food waste represents a resource of 24.4 billion kilograms of COD per year. Landfilling is the most common method of food waste disposal (~54%) but composting, incineration, anaerobic digestion, gasification, combustion, torrefaction, and pyrolysis are also used (Arena, 2012; Mata-Alvarez, Macé, & Llabrés, 2000; USEPA, 2014; Weiland, 2010; Yuan et al., 2015).

Similarly, wastewater sludge generated during the treatment of domestic and industrial wastewater represents a second potential energy resource. In the US, the effluent standards for secondary wastewater treatment are 30 mg/L Biochemical Oxygen Demand (BOD) (US EPA, 2017). The relationship between BOD and COD has been estimated by a ratio of 0.5 BOD to COD (Hays, Zhang, & Logan, 2011). In addition, sewage sludge contains nitrogen, phosphorus, heavy metals, and other compounds which could be harvested and recycled for use in other processes (Oller, Malato, & Sánchez-Pérez, 2011; Prieto-Rodríguez et al., 2013; George Tchobanoglous, Burton, & Stensel, 2003). In the US, each person produces approximately 80 g of sewage solids per day which are treated in water resource recovery facilities (WRRFs), leading to a production rate over 9 billion kilograms per year, which is equivalent to 13.40 billion kilograms of COD per year. (Jenicek, Bartacek, Kutil, Zabranska, & Dohanyos, 2012). Conventional disposal methods for sewage sludges include anaerobic digestion, fermentation, gasification, incineration, and pyrolysis (Appels, Baeyens, Degreé, & Dewil, 2008; Fytli & Zabaniotou, 2008; Luque, Menéndez, Arenillas, & Cot, 2012). A summary of the energy resources provided by food waste and sewage sludge is provided in Table 1. Many of the disposal methods for food waste and sewage sludges rely on thermochemical processes, but these are typically less energy efficient, due to high moisture content (Scherson & Criddle, 2014).

In contrast, biological processes represent a group of technologies capable of generating energy from waste without the need to reduce moisture content. Anaerobic digestion (AD) represents a mature biological treatment process but more recently, bioelectrochemical systems (BES) have been proposed to treat sewage sludge and other substrates, such as food waste, in addition to anaerobic digestion (Adrián Escapa, Martin, & Moran, 2014; Pant et al., 2013; T. H. Pham et al., 2006). Furthermore, the biological treatment processes used in this study have the potential to eliminate the need for aerobic treatment, a common component of the conventional

water treatment process, which consumes upwards of 1.5% of total electricity demands in developed countries (Appels et al., 2008; Goldstein & Smith, 2002; H. Li, Jin, Mahar, Wang, & Nie, 2008; McCarty, Bae, & Kim, 2011). AD and BES can be integrated into waste treatment processes to establish net-energy positive treatment facilities (Gao, Scherson, & Wells, 2014; McCarty et al., 2011; Water Environment Federation, 2014).

Table 2. Summary of Food Waste and Wastewater Energy Content and Energy Recovery

Waste Type	Resource Energy Content				
	Energy Content (kWh/kg COD)	Mass of Resource (billion kg COD)	Energy Resource (billion kWh)	Mass per Person (kg per person)	Energy per Person (kWh per person)
Food Waste	2.95	24.40	71.98	76.25	224.94
Sewage Sludge	4.08	13.40	54.67	41.88	170.84

Anaerobic digestion (AD) is a robust, mature bioconversion process that can utilize both food waste and sewage sludge as substrate (Appels et al., 2008; Mata-Alvarez et al., 2000). The anaerobic digestion process is divided into 3 essential steps: hydrolysis, acidogenesis/acetogenesis and methanogenesis (Weiland, 2010). Acetate is the preferred substrate for acetogenic methanogens, which account for roughly two-thirds of the methane production in an anaerobic digester when using acetate as a substrate (Y. Liu & Whitman, 2008; Zinder, 1993). Methane produced during AD can be converted into electricity and heat, which can be used to offset energy use in MSW facilities and WRRFs. To supplement the performance of AD, it has been proposed that bioelectrochemical systems (BES) can be used as a secondary treatment stage (T. H. Pham et al., 2006). Two BES technologies will be used in this study, the first of which is the microbial fuel cell (MFC). This system is comprised of two electrodes, an anode and a cathode, separated by an electrolyte, shown in Figure 2. However, these differ from conventional fuel cells due to the utilization of bacteria at the anode to oxidize organic and inorganic fuels (Logan et al., 2006). The oxidation of organic substrates generates protons and electrons, which ultimately combine at the cathode. To generate energy from metabolism, electrons from the substrate must be transferred to a final electron acceptor at a higher potential. More energy can be generated from the substrate when the redox potential between the anode and substrate is large. The anode potential dictates the metabolic pathways utilized by microbes and the microbial community composition (Rabaey & Verstraete, 2005). In practice, this is kept low to facilitate oxidative metabolism, provided there are alternative electron acceptors present. Most MFC experiments are carried out at small scales, which typically do not experience the same electrochemical losses as large-scale systems. A review of laboratory and pilot systems was reported in Janicek et al 2014 (Janicek, Fan, & Liu, 2014). The second BES technology considered in this study is the microbial electrolysis cell (MEC). The design of MECs is similar to MFCs but operates with an anaerobic cathode and with the application of an external potential (>0.3V) resulting in the production of hydrogen at the cathode (Figure 2) (S. Cheng & Hamelers, 2008). In comparison, conventional water electrolyzers require 1.8-2 V to produce hydrogen gas (H. Cheng et al., 2002). It is estimated that MECs will require 0.29 kWh per cubic meter of

hydrogen gas produced, which in most cases will be mitigated by the energy content of the produced hydrogen. Interest in MECs has increased significantly in the past few years due to its ability to produce hydrogen and its operational advantages over MFCs (A. Escapa, Mateos, Martínez, & Blanes, 2016; Adrián Escapa et al., 2014). A review of small and large-scale MECs was reported by Escapa et al 2016 (A. Escapa et al., 2016). A summary of notable AD and BES studies referenced in this report are shown in Table 2.

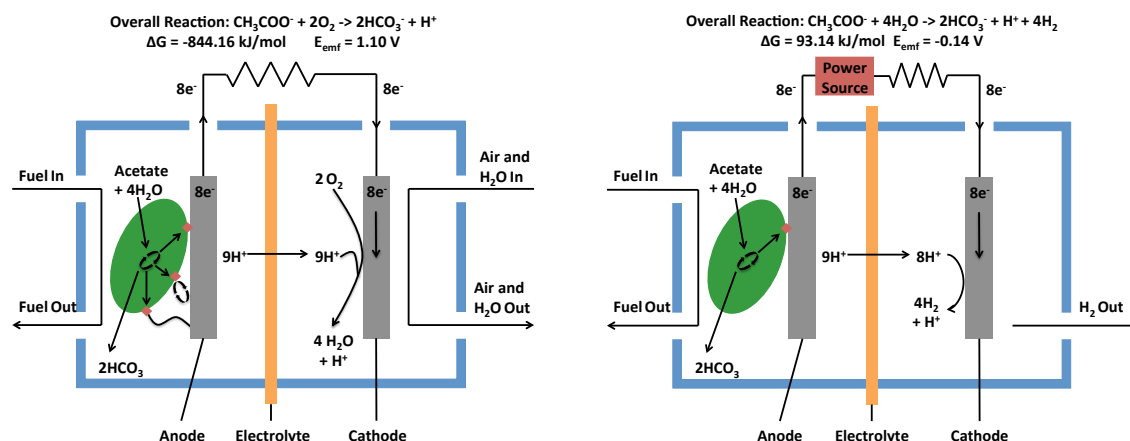

Figure 2. Schematic of a Microbial Fuel Cell (Left) and a Microbial Electrolysis Cell (Right)

Previous publications have reported on the principles that outline AD and BES processes, however the focus is often only on theoretical performance (S. Cheng & Hamelers, 2008; Gunaseelan, 1997; Logan et al., 2006; Rabaey & Verstraete, 2005; Rozendal, Hamelers, Rabaey, Keller, & Buisman, 2008; Weiland, 2010). While these reviews are useful for demonstrating fundamental concepts for these technologies, there is a failure to address the expected performance of these technologies with complex substrates, which is required for the planning of these systems in the real world. This report proceeds in four parts: 1) an evaluation of theoretical energy efficiency and performance based on acetate as an ideal substrate, 2) a review of the state-of-the-art for anaerobic digestion (AD), microbial fuel cells (MFCs), and microbial electrolysis cells (MECs) at laboratory and pilot scales, 3) estimation of energy efficiency and performance using complex wastes at large scales, and 4) calculation of potential economic and environmental benefits, using ORNL WRRF as a case study. This WRRF has an average daily capacity of 0.2 MGD with an average incoming COD of 300 mg/L. To address the flexibility of these technologies, in part 3, we will investigate AD and BES technologies as standalone and integrated processes (Figure 3). The goal of this study is to investigate a group of bioconversion systems capable of maximizing the energy recovery from abundant waste streams. The study concludes with a discussion of the energy efficiency losses and current methods available to reduce the gap between theoretical and practical efficiencies.

Scientific Methods

Calculation of Energy Efficiencies

The following section investigates the essential parameters needed to evaluate the energy efficiencies of AD and BES systems for different substrates. Figure 3 illustrates the

configurations used to evaluate food waste and sewage sludge as energy sources. In order to compare the different processes, a common end-product is necessary. Electricity was chosen as the standard end-product for direct comparison of viable energy yield from each process. In this study, proton exchange membrane fuel cells (PEMFCs) were used to convert hydrogen gas produced by MECs into electricity and gas turbines were used to convert biomethane to electricity. The theoretical maximum energy yields for each technology were estimated using chemical oxygen demand (COD), an indirect measure of the organic content, which can also be used to evaluate waste. Acetate was used as a primary substrate for these evaluations. To evaluate energy production from food waste and sewage sludge, a loading rate of one kg COD equivalent/day of food waste and wastewater was added to each process, respectively. The differences in performance from food waste and wastewater yields compared to theoretical yields with acetate is used to illustrate the efficiency losses due to the complexity of substrates and overpotentials in waste-to-energy processes.

Calculation of Theoretical Energy Efficiencies using Acetate

The theoretical energy efficiency of AD and BES was estimated using acetate as a substrate. It is assumed that all the electrons contained in an acetate molecule are oxidized and utilized by the microbial communities. Our theoretical calculations include metabolism losses reported by Foley et al 2010, which divert electrons destined for current production to microbial growth (Foley, Rozendal, Hertle, Lant, & Rabaey, 2010). In this analysis, we assume that 12% of incoming COD is lost to microbial growth in AD and 15% of incoming COD is lost in BES.

Microbial Fuel Cell

The energy efficiency for MFCs is calculated by converting the incoming COD into the theoretical current that can be produced from the respective substrate (Equation S1). This, in addition to the theoretical voltage determined by the Nernst equation, determines the theoretical energy production of any substrate, in this case acetate. The theoretical efficiency of this system is then determined by comparing the daily energy output to the chemical energy of acetate, 3.778 kWh/kgCOD (Haandel & Lubbe, 2007). Equations 32-42 in the appendix illustrate the calculations needed to determine the theoretical current and voltage of an MFC. Equations 1-5 below summarize the key results from this analysis. Note that the theoretical efficiency is not 100%, due to losses from microbial growth and the calculations using the Nernst equation in non-standard conditions.

$$Eq. 1 \quad I_{MFC} = 118.60 A$$

$$Eq. 2 \quad V_{MFC} = V_{cat} - V_{an} = 1.10 V$$

$$Eq. 3 \quad E_{MFC} = I_{MFC} * V_{MFC} * \frac{24hr}{\left(\frac{1000W}{1kW}\right)} = 3.14 kWh$$

$$Eq. 4 \quad E_{Acetate} = 3.78 kWh$$

$$Eq. 5 \quad \eta_{MFC} = \frac{E_{MFC}}{E_{Acetate}} = 82.98\% \text{ efficiency}$$

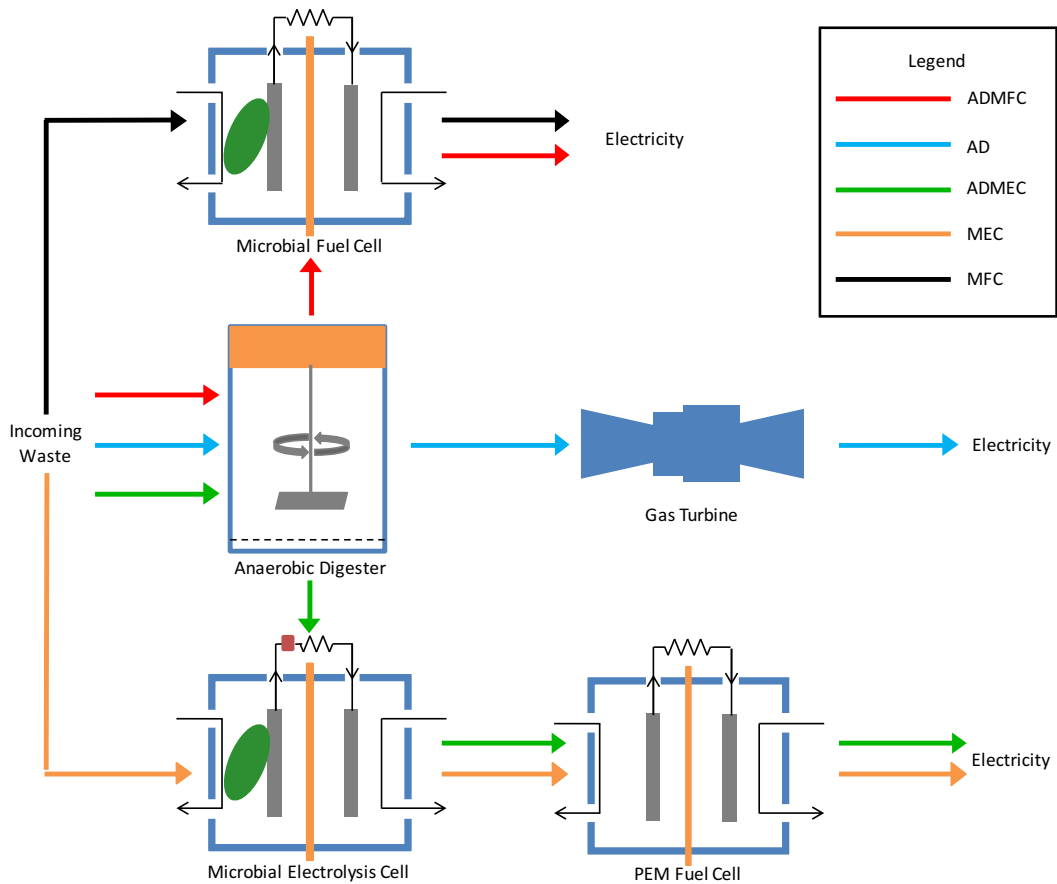

Figure 3. Configurations of waste to energy systems. ADMFC (Red) combines an AD with a downstream MFC. AD (Blue) uses only digestion. ADMEC (Green) combines an AD with a downstream MEC. MEC (Orange) and MFC (Black) use only microbial fuel cells or microbial electrolysis, respectively. All systems ultimately generate electricity.

Microbial Electrolysis Cell

Similarly, for MECs, the theoretical current generated from acetate was calculated, as well as the theoretical hydrogen production. Due to the operational differences between MFCs and MECs, the latter requires an input of energy to enable the production of hydrogen. The theoretical energy requirement for this system is calculated using the Nernst equation, equations 43-54 in the appendix. As mentioned above, the hydrogen gas produced is converted into electricity via a proton exchange membrane fuel cell (PEMFC), which operates at a theoretical efficiency of 83% (Winkler & Nehter, 2008). The energy efficiency of the system is calculated by combining the electrical energy equivalent produced by the MEC with the chemical energy of acetate and the electricity requirement. Equations 6-11 below summarize the key equations for MEC energy efficiency:

$$\text{Eq. 6} \quad I_{MEC} = 118.60 \text{ A}$$

$$\text{Eq. 7} \quad Y_{H_2} = 1.19 \text{ m}^3 \text{ H}_2$$

$$\text{Eq. 8} \quad V_{MEC} = V_{cat} - V_{an} = -0.14 \text{ V} = V_{app}$$

$$\text{Eq. 9} \quad E_{MEC} = Y_{H_2} * \frac{3.29 \text{ kWh}}{\text{m}^3 \text{ H}_2} * 83\% \text{ PEMFC}_{eff} = 3.25 \text{ kWh}$$

$$\text{Eq. 10} \quad E_{app} = V_{app} * I_{MEC} * \frac{24 \text{ hr}}{\frac{1000 \text{ W}}{1 \text{ kW}}} = -0.39 \text{ kWh}$$

$$\text{Eq. 11} \quad \eta_{MEC} = \frac{E_{MEC}}{E_{acetate} + E_{app}} = 78.01\%$$

Anaerobic Digester

Acetate is an essential metabolite in the anaerobic digestion process, where it is generated as an intermediate from fermentation and is consumed by methanogens for methane production. From the literature, the reported theoretical yield of methane is 0.35 m³/kgCOD, assuming no metabolic losses (E. S. Heidrich, Curtis, & Dolfing, 2011). This occurs when 64 gCOD converts to 1 mole of methane. In our analysis, we included losses for microbial growth, estimated at 12% of COD (Foley et al., 2010). In addition, the methane generated from AD, with a heating value of 10.35 kWh/m³, is converted to electricity at an efficiency of 38% (Eurelectric, 2003). A summary of the AD efficiency analysis is shown in equations 12-14 and equations 55-57 in the appendix show these calculations in greater detail.

$$\text{Eq. 12} \quad Y_{CH_4} = 0.34 \frac{\text{m}^3}{\text{day}}$$

$$\text{Eq. 13} \quad E_{AD} = 1.34 \text{ kWh}$$

$$\text{Eq. 14} \quad \eta_{AD} = \frac{E_{AD}}{E_{acetate}} = 35.39\%$$

Combined Anaerobic Digester and Bioelectrochemical Systems

For the next two configurations, AD was combined with MFCs or MECs to illustrate a more robust waste treatment design. In both of these configurations, the AD is assumed to remove 80% of the available COD. The remaining 20% COD present in the AD effluent is fed into either

a MFC or MEC. The value of 80% COD removal was chosen for the digester because it is a conservative estimate for current digester technology, compared to values used in a recent Life Cycle Analysis (LCA) study (Foley et al., 2010). A summary of these results is shown in equations 15-18 for the ADMFC process and equations 19-23 for the ADMFC process.

Combined AD/MFC

$$\text{Eq. 15} \quad E'_{AD} = E_{AD} * 80\% \text{ removal} = 1.07 \text{ kWh}$$

$$\text{Eq. 16} \quad I'_{MFC} = I_{MFC} * 20\% = 23.72 \text{ A}$$

$$\text{Eq. 17} \quad E'_{MFC} = I'_{MFC} * V_{MFC} * \frac{24\text{hr}}{\left(\frac{1000\text{W}}{1\text{kW}}\right)} = 0.63 \text{ kWh}$$

$$\text{Eq. 18} \quad \eta_{ADMFC} = \frac{E'_{AD} + E'_{MFC}}{E_{acetate}} = 44.89\% \text{ efficiency}$$

Combined AD/MEC

$$\text{Eq. 19} \quad I'_{MEC} = I_{MEC} * 20\% = 23.72 \text{ A}$$

$$\text{Eq. 20} \quad Y'_{H_2} = Y_{H_2} * 20\% = 0.24 \frac{\text{m}^3\text{H}_2}{\text{day}}$$

$$\text{Eq. 21} \quad E'_{MEC} = Y'_{H_2} * \frac{3.29\text{kWh}}{\text{m}^3\text{H}_2} * 83\% \text{ PEMFC} = 0.65 \text{ kWh}$$

$$\text{Eq. 22} \quad E'_{app} = V_{app} * I'_{MEC} * \frac{24\text{hr}}{\frac{1000\text{W}}{1\text{kW}}} = -0.08 \text{ kWh}$$

$$\text{Eq. 23} \quad \eta_{ADMFC} = \frac{E'_{AD} + E'_{MEC}}{E_{acetate} + E'_{app}} = 44.58\%$$

Calculation of Practical Energy Efficiencies using Acetate

In this section, the performance parameters from a range of anaerobic digestion, microbial fuel cell, and microbial electrolysis cell studies were compared. A summary of this literature review is presented in Table 3. The analysis in this report focused on the performance of large-scale studies to illustrate the barriers to scaling up this technology. The results from these studies were used to estimate the expected performance of AD and BES in real lab and/or pilot-scale conditions. For our analysis, we assumed that substrate fed into the system is readily biodegradable by microorganisms and the only losses in the system, in addition to losses to microbial growth, are those created by thermodynamic constraints and design inefficiencies. The efficiencies for gas turbines and PEMFCs are the same as above for this analysis.

Microbial Fuel Cells

Several pilot-scale studies have been carried out using MFCs. The substrates used in these studies vary but many utilize synthetic wastewater. From the literature survey, the voltage observed at the maximum power point was between 0.2-0.5V. In this study, an MFC voltage of 0.3 V was used to forecast the expected improvements in large-scale MFC designs (Borole, Hamilton, Vishnivetskaya, Leak, & Andras, 2009; Dekker, Ter Heijne, Saakes, Hamelers, & Buisman, 2009; Z. Li, Yao, Kong, & Liu, 2008; Ter Heijne et al., 2011)

Table 3. Literature Review of Selected Technologies

Platform	Substrate	Reactor Size (l)	Retention Time (d)	Applied or Maximum Power Voltage	COD removal (%)	Biogas Production (L/L*d)	Hydrogen Production (L/L*day)	Power Density Wm ⁻² (Wm ⁻³)	CE (%)	Reference
AD	Waste Activated Sludge	3,400,000	16	-	NA	0.18	-	-	-	(Bolzonella, Pavan, Battistoni, & Cecchi, 2005)
AD	Separated Food Waste	900,000	80	-	NA	1.51	-	-	-	(Banks, Chesshire, Heaven, & Arnold, 2011)
AD	Food Waste	60	20-60	-	NA	2.5 - 8.0	-	-	-	(Cho et al., 2013)
AD	OFMSW and Sludge	30	38	-	NA	1.00	-	-	-	(Sosnowski et al., 2003)
MEC	Domestic WW	0.3	4.5**	0.2-0.6	90	-	NA	-	26	(Ditzig, Liu, & Logan, 2007)
MEC	Domestic WW	4	0.17	1	85	-	0.05	-	719*	(Gil-Carrera, Escapa, Moreno, & Moran, 2013)
MEC	Domestic WW	4	0.17	0.6 and 1.0	80	-	0.02	-	190*	(Gil-Carrera, Escapa, Carracedo, Moran, & Gomez, 2013)
MEC	Domestic WW	3	8**	0.7	92	-	0.02	-	238*	(a. Escapa, San-Martín, Mateos, & Morán, 2015)
MEC	Domestic WW	3	0.28	0.7	75	-	NA	-	344*	(a. Escapa et al., 2015)
MEC	Domestic WW	100	1.00	0.6-1.1	33.7	-	0.015	-	55	(E. S. Heidrich et al., 2013)
MEC	Domestic WW	100	1.00	0.6-1.1	65.6	-	0.007	-	41	(Elizabeth S. Heidrich, Edwards, Dolfing, Cotterill, & Curtis, 2014)
MFC	Sludge w/ Synthetic feed	1.5	3.8**	~0.45	88	-	-	0.133 (2.02)	-	(Z. Li et al., 2008)
MFC	Synthetic WW	5	0.0006	0.475	NA	-	-	2 (200)	-	(Ter Heijne et al., 2011)
MFC	Synthetic WW	7.5	0.26	0.213-0.300	69-97	-	-	(2-10)	-	(Clauwaert, Mulenga, Aelterman, & Verstraete, 2009)
MFC	Synthetic WW	20	0.0049	0.25	NA	-	-	1.44 (144)	-	(Dekker et al., 2009)
MFC	Acetate***	0.02	0.0016	~0.5	NA	-	-	3.650 (345)	-	(Borole, Hamilton, Vishnivetskaya, Leak, & Andras, 2009)

* High CE values from hydrogen recycling; ** Batch Operation; *** Fed with Ferricyanide

Microbial Electrolysis Cells

Like MFCs, several pilot-scale studies have been carried out using MECs. However, many of these studies have used domestic wastewater as a substrate. From our literature survey, we looked at the applied voltages required and the Coulombic Efficiency (CE), a percentage that estimates the electrons recovered in hydrogen from substrate, in each study and used these values in our energy efficiency calculations. Hydrogen production was estimated by multiplying the theoretical hydrogen production by the Coulombic Efficiency. The applied voltage was estimated at 0.6 V and the practical CE for pilot-scale systems was assumed to be 50%. The low CE is due to factors experienced in real systems, such as electron scavengers in the consortium, limited biodegradability of substrate, etc.

Anaerobic Digestion

From our literature survey, the highest efficiency obtained in an AD study was reported by Wei et al 2014, which demonstrated a methane yield of 0.32 m³/kgCOD (Wei, Harb, Amy, Hong, & Leiknes, 2014). Using this methane yield, the revised energy efficiency for AD is 33.3%.

Calculation of Practical Energy Efficiencies using Complex Wastes

In this final section on energy efficiency, the effects of utilizing substrates that are not completely biodegradable was evaluated. As mentioned above, food waste and sewage sludge are two renewable biomass feedstocks that could be used to generate energy via anaerobic digestion and bioelectrochemical systems. However, there are significant energy efficiency losses based on the literature survey of laboratory and pilot-scale studies. To investigate energy production from more realistic feedstocks, we reviewed the conversion of complex substrates in the literature and estimated the energy efficiencies of these processes. A biodegradability factor was included in the calculations. The biodegradability of food waste and sewage sludge was found to be 53% and 63%, respectively, based on the literature (Bougrier, Albasi, Delgenès, & Carrère, 2006; Labatut, Angenent, & Scott, 2011; Verma, 2002). In addition, the energy content of these substrates is different from acetate. As such, the energy content of food waste and sewage sludge was estimated at 2.95 kWh/kgCOD and 4.08 kWh/kgCOD, respectively (Cho et al., 2013; E. S. Heidrich et al., 2011; G Tchobanoglous, Thiesen, & Vigil, 1993).

Economic and Environmental Analysis

Economic Analysis

A case study was developed to investigate the potential economic and environmental impacts of implementing an AD/BES treatment system at the ORNL WRRF, based on the practical energy efficiencies for complex wastes. The intent of this analysis was to identify the treatment platform with the greatest economic potential and pursue the selected technology further in Chapter 2. This facility has an average daily capacity of 757 m³/d with an average incoming COD of 300 mg/L. The simplified economic and environmental impacts were based on several factors. For economic analysis, we calculated the expected capital costs, operational costs, product revenue, and the net present value (NPV) for the system after 20 years. The annual revenue was discounted at a rate of 1% to estimate the 20-year net present value (NPV), in accordance with the US federal discount rate in 2016. Equation 24 shows the discounted cash flow calculation and Equation 25 shows the NPV calculation:

$$\text{Eq. 24} \quad C_T = \text{Cash Flow} = \frac{(\text{Rev} - O\&M)}{(1+r)^t}$$

Eq. 25
$$NPV = \sum_{t=1}^T [C_T] - C_0$$

Where discounted cash flow is calculated as the difference between revenue and O&M costs, divided by the discount rate, and NPV is calculated as the sum of discounted cash flow, minus the initial capital costs. In this analysis, each configuration was evaluated on the primary products created by the process; the systems were not standardized to electricity production. This change is to reflect the variable economic value of products like hydrogen, electricity, and biogas. This also opens the door for other products to be evaluated which may have greater economic value, i.e. hydrogen peroxide. This analysis was performed by scaling the practical energy efficiency values for sewage sludge to an industrial scale, given the resource masses in Table 2. For capital cost, reported values of \$100,000/tonCOD*day and \$1220/m³ were used for AD and BES, respectively (A. Escapa, Gómez, Tartakovsky, & Morán, 2012; T. H. Pham et al., 2006). The operational costs were estimated at \$0.05/kgCOD, \$0.11/kgCOD, and \$0.048/kgCOD, respectively for MFC, MEC, and AD (Moriarty, 2013; T. H. J. a Sleutels, Ter Heijne, Buisman, & Hamelers, 2012). The respective volumes for MFCs and MECs were estimated based on a 20 gCOD/L*day organic loading rate (OLR) which corresponds to a 11.35 m³ anode reactor. Lastly, the revenue values for hydrogen gas, biogas, and electricity in Tennessee were \$0.10/kWh, \$0.03/kWh, and \$0.06/kWh, respectively (Administration, 2016; Energy, 2013; SoCalGas, 2013). Additional details are provided in the appendix, Tables 13-18.

Environmental Analysis

The environmental benefits analysis performed in this report only considers the equivalent carbon dioxide emissions savings by: reducing electricity demand for aerobic wastewater treatment and reducing fossil fuel demand for electricity generation. This reflects the benefit of adopting anaerobic treatment technologies compared to aerobic treatment. The values estimated here are useful for demonstrating the comparative benefits of these technologies, however a determination of all emissions from individual processes will require a complete Life Cycle Analysis (LCA) on the system. The estimated emissions offset by reduced electricity generation demand considered the US energy mix for electricity production and the carbon intensity of each energy source. In the US, the energy mix for electricity production is 46% coal, 21% nuclear, 20% natural gas, 13% renewable, and 1% petroleum (Association Energy Information, 2012). The carbon intensity of each source, as well as a summary of the economic values and US energy mix using in the calculations, is presented in Table 18. The value for reduced aerobic treatment demand was calculated by multiplying the total US electricity by 1.5% for aerobic treatment and then multiplying this value by the carbon intensity factor. The reduced fossil fuel demand value was calculated by estimating the recoverable energy of sewage sludge, based on the energy efficiency of the ADMEC platform, and calculating the carbon intensity of this energy to indicate the quantity of carbon being reduced.

Results

Energy Efficiencies

The analysis performed in this report investigated the theoretical and practical energy efficiencies of ideal and complex substrates. The methods described above were used to compare the expected energy efficiencies of AD and BES processes with practical energy efficiencies observed in several laboratory studies. The results are also given in Tables 7-10 in the appendix. The bar graph in Figure 4 represents this information so that the difference between theoretical and practical efficiencies are clearer. It is important to note that the differences in efficiency are

largest in the bioelectrochemical systems. Although the efficiencies are quite low given the current state-of-the-art, there is room for improvement. Increasing the efficiencies of BES technology will lead to significant economic and environmental benefits, as discussed below.

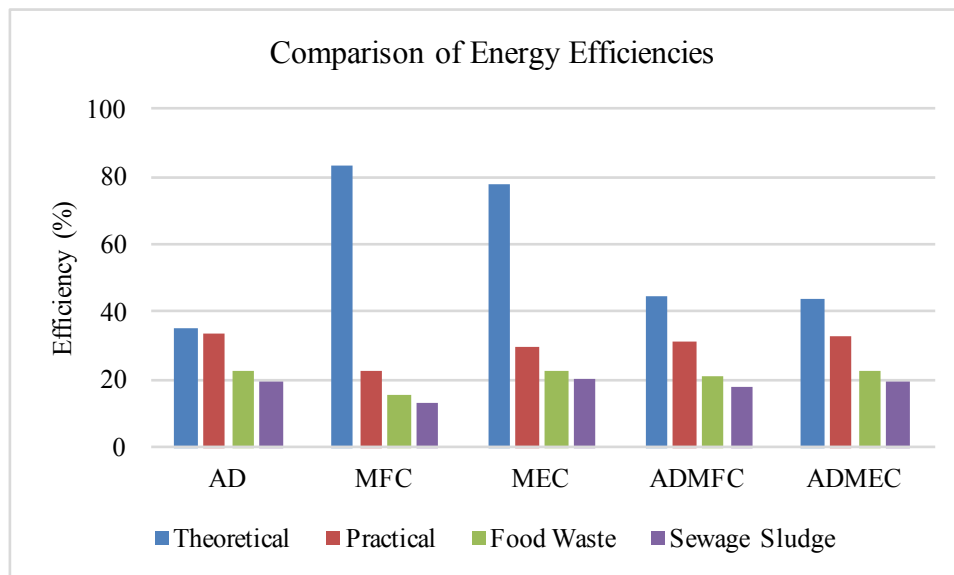

Figure 4. Comparison of energy efficiencies for waste conversion processes.

Although the energy efficiencies of BES are very high as standalone processes, these technologies are not adequate to handle the high solid content of complex waste streams, such as food waste and sludge. As such, BES can be used as secondary processes to AD, which are capable of processing high solid content. The combined systems also have a smaller energy efficiency gap to overcome for commercialization. To evaluate the feasibility of these configurations, a brief economic and environmental analysis was performed for all configurations at the ORNL Water Resource Recovery Facility (WRRF).

Economic Benefit

The Oak Ridge National Laboratory WRRF has a capacity of 757 m³/d and has an average influent COD of 300 mg/L. Using the determined energy efficiencies for sewage sludge in section 3.1, the 20-yr net present value for each treatment system was calculated (Table 3). The capital costs, revenue, and operational costs were listed above. The annual energy resource available for the ORNL WRRF was estimated at 200,435.55 kWh, based on the incoming COD concentration and the chemical energy potential of sewage COD, as determined by Heidrich et al 2011 (E. S. Heidrich et al., 2011). From this analysis, no system showed a positive return, however the ADMEC and ADMFC systems were significantly closer than AD or BES alone. The negative NPV is largely due to the low annual revenues and relatively high O&M costs for each system, which were both calculated as a function of influent COD. The key strategies to improve NPV to maintain high product yield while decreasing capital and O&M costs. Some strategies are addressed below in the discussion. Improving the electrochemical energy efficiencies of BES is a key parameter for improving NPV. A value of BES that was not

explored in this study is the production of non-energy products, like hydrogen peroxide. These products have greater value than electricity and could be used to supplement the revenue of the proposed configurations. Hydrogen peroxide could also be used to mitigate chemical expenses for disinfection at some WRRFs. In addition, the capital costs for BES systems are very high, relative to AD. The scaling factor of \$1,220/m³-anode is optimistic for the current state of the art and real systems will likely have much higher capital costs. This is expected because the technology is relative new but it also requires expensive electrical components and membranes to support high conversion efficiencies. Overall, the combination of relatively moderate capital costs, high revenue potential, and moderate O&M costs suggests that the ADMEC or ADMFC platform are ideal for wastewater treatment, compared to AD or BES alone.

Table 4. Net Present Value of Case Study

	CAPEX	Revenue	O&M	20-yr NPV
AD	-\$22,712.46	\$1,299.44	\$3,979.22	-\$71,070.68
MFC	-\$13,847.00	\$1,599.88	\$4,145.02	-\$59,775.59
MEC	-\$13,847.00	\$4,008.71	\$9,119.05	-\$57,354.22
ADMFC	-\$20,939.37	\$1,427.88	\$4,012.38	-\$42,942.71
ADMEC	-\$20,939.37	\$1,801.20	\$5,007.19	-\$48,233.72

Environmental Benefits

The environmental benefits in this analysis only consider the equivalent carbon dioxide emissions savings by: reducing electricity demand for aerobic wastewater treatment, and reducing fossil fuel demand for electricity generation. This simplified analysis excludes other sources of emissions such as from transportation of waste and the incineration and disposal of residuals. A look at the energy demand of conventional wastewater treatment shows that carbon dioxide emissions can be reduce by offsetting the need for aerobic treatment. In the US, 3% of total electricity produced is consumed by wastewater treatment and half of that is used for aerobic treatment. In 2016, the US consumed 11,066 billion kWh of electricity (US Energy Information Administration, 2017). If the bioconversion systems in this study could be implemented and eliminate the need for aerobic treatment, 1.5% (166.5 billion kWh) of the total national electricity demand would be reduced. The existing energy mix for electricity generation shows that 46% of electricity comes from coal, 21% from nuclear power, 20% from natural gas, 13% from renewables, and 1% from petroleum (Association Energy Information, 2012). Nuclear power and renewables do not generate CO₂ emissions directly so they will not contribute to greenhouse gas emission reductions in this analysis. The carbon intensity of coal, natural gas, and petroleum are 1.58, 0.88, and 1.183 kgCO₂/kWh-e, Table 18 (EIA, 2013). By multiplying the carbon intensity of each fossil fuel by its contribution to electricity demand, a carbon intensity factor of 0.91 kgCO₂/kWh was determined. The carbon dioxide savings from reducing 1.5% of the national electricity demand can be estimated. The potential emission savings from eliminating aerobic waste treatment are 152 billion kgCO₂-equivalent.

Lastly, the electrical energy generated from wastewater sludge conversion can be used to offset additional fossil fuel demand in the electricity sector. The ADMEC configurations was selected due to its viability as a treatment platform. Operating at an energy efficiency of 20%,

see above, an estimated 10.7 billion kWh of electrical energy can be recovered from sewage sludge in the US. By using the carbon intensities of fossil fuels from the previous paragraph, it is estimated that nearly 9.74 billion kgCO₂-equivalent can be reduced. Overall, the total emissions savings from implementing food waste and wastewater conversion processes can be estimated at 160 billion kgCO₂-equivalent, shown in Figure 5. Over 94% of these emission reductions come from the reduced energy demand for aerobic wastewater treatment.

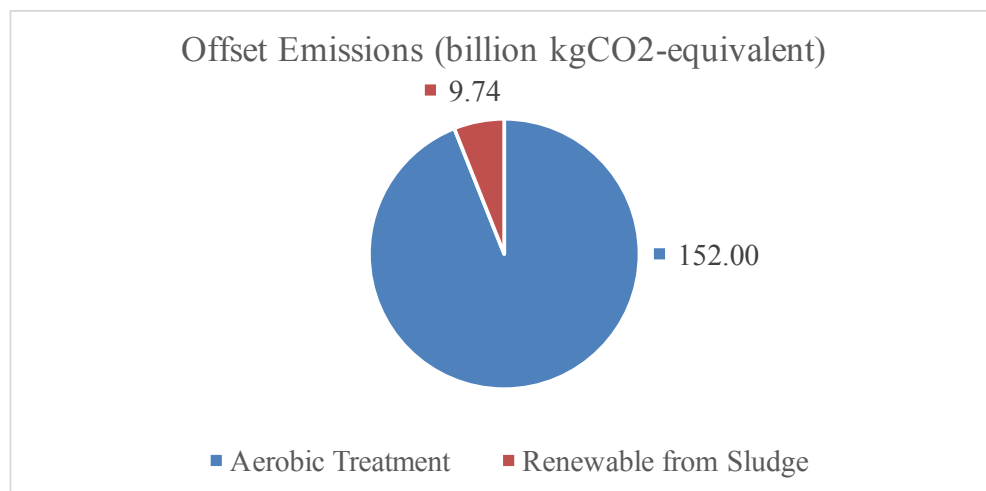

Figure 5. Offset Carbon Dioxide Equivalent Emissions by Source. Reported in billion kg CO₂-equivalent. All values are reported in billion kg CO₂-equivalent. The plot shows emissions from offset energy demand for aerobic water treatment (Blue) and the offset emissions from renewable energy generation from sludge (Red).

Discussion

The integration of anaerobic digestion and bioelectrochemical system has the potential to recover nutrients and organic compounds from complex waste streams and transform them into energy and other valuable products. In this study, the energy efficiencies of these systems were evaluated to illustrate the technology gap between theoretical and practical efficiencies. Furthermore, the economic analysis showed that most of the systems studied in this paper would not likely have a favorable financial return based on current technology and costs. Progress toward increasing the energy efficiencies of these systems, reducing capital and operational costs, and pretreatment of complex waste streams are all strategies that can improve the feasibility of AD and BES technologies.

As indicated in Figure 4, there is a large energy efficiency gap between theoretical and practical performance for BES, which is a barrier to commercialization for this technology. The inefficiencies in BES can be attributed to four factors, called overpotentials: (1) ohmic losses, (2) activation losses, (3) concentration losses, and (4) metabolic losses (Borole, Reguera, et al., 2011; S. Cheng & Hamelers, 2008; Logan et al., 2006; Rabaey & Verstraete, 2005). Ohmic losses are characterized by the resistance of the system to the transport of protons through the electrolyte and electrons in external circuits. The spacing between electrodes and the conductivity of the medium are factors that affect ohmic losses (Logan et al., 2006). Activation

losses occur due to the thermodynamic limits of redox reactions taking place at the surface of electrodes and bacteria. These overpotentials are more prevalent at low current densities. Concentration losses are the result of mass transfer limitations at the anode and cathode and are prominent at high current densities. Lastly, metabolic losses are generated by the allocation of electrons to microbial growth and by the divergence of electrons to undesirable metabolic pathways in the microbial communities.

The optimization and improvement of BES designs and operation are a key research area to improve overall energy efficiency. For both MEC and MFC experiments, the most common reactor types are tubular and flat-plate designs. MFC studies tend to favor tubular reactors because they maintain plug-flow-like conditions with stable flow regimes (JR Kim, Rodríguez, & Hawkes, 2011). While MEC studies also favor tubular and flat-plate designs, some alternative designs have been proposed, notably an MEC using the walls of an anaerobic digester as a cathode, a tubular reactor using a conductive nickel-based hollow fiber membrane as a cathode, and a reactor consisting of granular activated carbon as a fluidized anode (Bo et al., 2014; Katuri & Werner, 2014; J. Liu, Zhang, He, Yang, & Feng, 2014). Important factors for BES design are electrode spacing, electrode surface area, and materials. A review by Janicek et al illustrates that a reduction in electrode spacing from 1 cm to 1 mm increases the power density in an MFC by over 150% from 0.907 W/m² to 2.34 W/m² (Janicek et al., 2014). Electrode spacing is influenced by reactor design (tubular vs. flat-plate), electrode material (brush, felt, granules, etc.), and the presence of a membrane separator (Rozendal et al., 2008). In general, the addition of a membrane separator facilitates the reduction of electrode spacing for MFCs and MECs. However, using a membrane will add to the capital costs of the system and may reduce performance due to the formation of pH gradients between anode and cathode and increased internal resistances (a. Escapa et al., 2015). The effect of pH on overpotentials can be determined by the Nernst equation; a change in voltage of 0.06 V occurs per unit pH change (Rozendal, Hamelers, Molenkamp, & Buisman, 2007). Increasing anode surface area is another strategy to improve current density in BES. Brush anodes have been used to increase the anode surface area, leading to increases in current densities, but during scale-up the electrode spacing increases, leading to overall losses (Hong Liu, Cheng, Huang, & Logan, 2008; Rabaey, Boon, Siciliano, Verstraete, & Verhaege, 2004). For scale-up, carbon cloths, fibers, and foams could be used successfully as anode materials due to their high surface area, surface properties, and conductivity, provided they can be produced at a low cost.

The delivery of substrate into a BES reactor and the electrochemical balance in the anode and cathode also needs to be addressed. Without adequate flow in the anode, pH gradients and some mass transfer limitations can occur, reducing current densities (Lee, Torres, & Rittmann, 2009; Torres & Marcus, 2008). The method of substrate addition, batch vs. continuous, also impacts current density, as well as consortia composition. In batch systems, high current densities are feasible for short periods but there are several drawbacks, such as the growth of undesired microorganisms, like methanogens (T. Sleutels, Molenaar, Heijne, & Buisman, 2016). In general, higher substrate concentration and loading rates will increase current production because substrate limitations are reduced. However, at very high substrate conditions, the excess substrate can be consumed in alternative metabolic pathways, such as methane production via methanogenesis, which will reduce the yield of current (Pannell, Goud, Schell, & Borole, 2016). The electrons diverted to alternative metabolisms result in lower Coulombic Efficiencies. In continuous systems, the flow of liquid can result in the development of shear force along the electrode surface. Shear rates can have profound effects on BES performance. Biofilms grown at

higher shear rates were found to be 5-times thicker and generated current densities 2-3 fold higher than lower shear rate biofilms (H. T. Pham et al., 2008). During the startup of a BES reactor, the external resistance needs to be monitored closely. High external resistances, compared to the internal resistance of the reactor, can select for methanogens. Thus, it is important to identify the internal resistance of the system, which will change during operation. The effect of external resistances has been investigated in MFCs. Borole et al 2009, employed a method of gradually decreasing the external resistance in an MFC over time and found an increase in current densities reaching as high as 800 A/m^3 (Borole, Hamilton, Vishnivetskaya, Leak, & Andras, 2009). However, lower external resistance can lead to thinner biofilms. McLean et al, observed that lower external resistances (100Ω) led to the formation of biofilms that were 10-fold thinner than biofilms developed at higher resistances ($1 \text{ M}\Omega$) (McLean et al., 2010). Interestingly, in this same study, the current production per cell was higher in the biofilm formed at lower external resistance. This suggests that conditions like external resistance can influence biofilm growth and structure to balance metabolism and electrode-respiration (Borole, Reguera, et al., 2011).

Strategies to reduce capital and operational costs have largely focused on finding lower-cost materials when constructing BES reactors. As mentioned above, there are alternative electrode materials for BES that could offer a low-cost alternative to conventional electrode materials in laboratory studies. Perhaps the largest single material cost for a BES reactor is the membrane. Nafion 117, a common proton exchange membrane, costs approximately $\$1,100/\text{m}^2$ (Pant et al., 2011). In several BES studies, several groups have investigated membrane-less systems to reduce capital costs and mitigate pH gradients between anode and cathode (An, Kim, Jang, Lee, & Chang, 2014; A. Escapa et al., 2009; a. Escapa et al., 2015). Additionally, conventional anaerobic digestion systems with long HRTs (~ 20 days) require large footprints, increasing the capital and operational costs. The development of membrane bioreactors (MBRs) and anaerobic membrane bioreactors (AnMBRs) could significantly reduce the HRT ($< 8\text{hr}$) and footprint of AD reactors. A study by Smith et al compared the life cycle costs between an AnMBRs, a high-rate activated sludge and AD, a conventional activated sludge and AD system, and an aerobic MBR and AD system. Although the overall capital costs of an AnMBR were higher than the other systems using medium-strength wastewater, the reduced sludge production greatly reduced the life cycle costs (Smith et al., 2014). It was also noted that if the hydraulic flux of MBR membranes could be doubled, the capital costs of an AnMBR system would be reduced by 46%. There are additional benefits and applications that support the adoption of AnMBRs, such as potable and non-potable wastewater reuse applications, mitigating the release of antibiotic-resistant bacteria, and decentralized water treatment.

One of the primary cost component of the operating expense (O&M) in an MEC is the electricity. The difference in the O&M costs shown in Table 3 for MEC and MFC related to the electricity costs. As it is seen from the Table, this amounts to more than half of the O&M cost. Renewable electricity is becoming increasingly abundant due to the surge in wind and solar power in some parts of the country. The diurnal trend in this form of energy has resulted in a change in the peak/off-peak hours of electricity availability on the grid (Aghaei & Alizadeh, 2013). In some cases, this creates an excess of electricity resulting a lower than usual cost of electricity (Joskow, 2011). This offers a potential opportunity for MECs to be deployed for use particularly when the electricity costs are low. The cost of hydrogen production can drop under these circumstances, making it economical in those parts of the country.

Lastly, inefficiencies of substrate bioconversion can also lead to energy recovery losses in all microbial systems. With complex substrates, such as food waste and municipal wastewater, significant fractions of the organic material are recalcitrant to microbes and cannot be converted into useful products or intermediates. Studies using model substrates typically report better performance but studies need to utilize real feedstocks to address existing concerns regarding commercialization. Several pretreatment processes can be implemented to further improve the energy recovery of these processes. Mechanical, chemical, biological, and thermal pretreatment processes have been shown to increase biogas production by 30-50%, increase methane composition in biogas and reduce solids by 20-60%, when using activated sludge (Bordeleau & Droste, 2011; Penaud et al., 1999). More innovative pretreatment procedures have been developed to address more recalcitrant organic compounds, like pharmaceuticals, pesticides, and endocrine-disrupting compounds. These include advanced oxidations processes (AOPs) like photocatalysis, ozonation, UV, hydrogen peroxide, and combined treatment processes (Agustina, Ang, & Vareek, 2005; Oller et al., 2011; Prieto-Rodriguez et al., 2012). Similar procedures and results have been produced using the organic fraction of MSW (Ariunbaatar et al., 2014). These processes could be applied before anaerobic digestion to increase the biodegradable fraction of organic material. Although many of these studies focus on anaerobic digestion, it is possible that pretreatment of waste before MFC or MEC reactors could also lead to improved efficiencies.

Conclusions

Microbe-based bioconversion processes represent a potential strategy to produce valuable energy products from waste sources. Implementing these processes could lead economic and environmental benefits. Although the practical efficiencies of these processes are low, there are many strategies available to overcome these barriers and create more efficient systems. This study investigated the use of bioconversion processes to improve the overall energy recovery from waste substrates. By implementing MFCs and MECs downstream of an anaerobic digester, the energy content in useful products was increased and led to overall energy efficiency improvements. The results in this study indicate that a combined ADMFC process could operate with a relatively high energy efficiency and robust treatment efficacy with the ability to produce high value energy products, like hydrogen gas. While the economic costs of an ADMFC system was not value positive in the ORNL use case, several strategies are available to improve the feasibility of these systems in the future. The analysis performed in this study could provide a foundation for other biomass sources to be evaluated. Energy crops, agricultural waste, animal waste, and the organic fraction of MSW are all viable substrates that can be co-digested together to produce energy, leading to additional economic and environmental benefits.

Acknowledgements:

This work was supported by funding from Oak Ridge National Laboratory. The work was co-authored by UT-Batelle, LLC, and was conducted under a contract No. *DE-AC05-00OR22725* with the U.S. Department of Energy. JRB was partially supported by the Bredesen Center for Interdisciplinary Research and Education.

Chapter 2: A New Perspective on Wastewater Energy Recovery Using Bioelectrochemical Systems and Anaerobic Digestion

Authors: Jeff Beegle and Abhijeet Borole

Literature Review

Wastewater treatment consumes nearly 3% of the total annual electricity demand in the US (McCarty et al., 2011). In the US, the effluent standards for secondary wastewater treatment are 30 mg/L Biochemical Oxygen Demand (BOD) (US EPA, 2017). The relationship between BOD and Chemical Oxygen Demand (COD) has been estimated by a ratio of 0.5 BOD to COD (Hays et al., 2011). In some facilities, over 50% of energy consumed is attributed to aerobic treatment methods, which require oxygen to be pumped and mixed in large treatment lagoons (Appels et al., 2008; Goldstein & Smith, 2002; WERF, 2011). Aerobic treatment stimulates the growth of aerobic microbes that can degrade the organic components present in raw wastewater. However, these methods generate a thick activated sludge, which must be treated before disposal in order to meet effluent standards (H. Li et al., 2008). The estimated cost of sludge treatment is 0.349 kWh per cubic meter of wastewater (Goldstein & Smith, 2002). The high-energy intensity of aerobic treatment and sludge treatment has led researchers to investigate wastewater solids as an energy resource. Two influential papers evaluated the chemical energy potential of raw wastewater solids and estimated that wastewater contains, on average, between 14.7 – 16.8 kJ/L, over nine times greater than the energy needed to treat incoming wastewater (E. S. Heidrich et al., 2011; Shizas & Bagley, 2004).

Thermochemical technologies, such as pyrolysis, gasification, and combustion, have been used to treat activated sludge, although they operate at low efficiencies (Oh et al., 2010; Scherson & Criddle, 2014). Anaerobic digestion (AD) has also been used to reduce sludge and generate biogas, but long payback times, concerns with system failure, and lack of outside support are still barriers to this technology (Willis et al., 2012). Several sludge pretreatment (PT) methods have been investigated as a preliminary step to AD with results indicating improvements in energy recovery, sludge biodegradability, biogas composition, and sludge stabilization (Ariunbaatar et al., 2014; Bordeleau & Droste, 2011; Carrère et al., 2010; Penaud et al., 1999; Yu et al., 2014). Alkaline pretreatment methods are effective in solubilizing sludge COD, with $\text{NaOH} > \text{KOH} > \text{Mg}(\text{OH})_2$ and $\text{Ca}(\text{OH})_2$, and showing increases in biogas production and COD conversion to biogas (Jeongsik Kim et al., 2003; Tanaka, Kobayashi, & Kamiyama, 1997). Thermal hydrolysis pretreatment also shows positive impacts on biogas production, volatile solids (VS) destruction, and COD conversion to biogas (Fdz-Polanco & Velazquez, 2008; Kepp, Machenbach, & Weisz, 2000; Neyens, Baeyens, & Creemers, 2003). Bioelectrochemical systems (BES) are a developing platform of technologies that convert organic materials into useable forms of energy, such as electricity or hydrogen gas (Hong Liu, Grot, & Logan, 2005; Logan et al., 2006; Rabaey & Verstraete, 2005; Rozendal et al., 2008). BES technologies are typically applied in one of two configurations, microbial fuel cells (MFCs) and microbial electrolysis cells (MECs). In both systems, a consortium is grown in an anaerobic anode chamber where incoming organic material is oxidized during respiration. The resulting electrons and protons are transported to the cathode where they combine to form either water, in aerobic systems, or hydrogen gas, in anaerobic systems. BES have been proposed as a companion technology to AD in several configurations. To date, most investigations into the integration of BES and AD have added electrodes within the digester vessel to improve

biological stability and energy recovery (De Vrieze et al., 2014; Koch et al., 2015; Sasaki et al., 2011; B. Tartakovsky, Mehta, Bourque, & Guiot, 2011; Boris Tartakovsky et al., 2014; Zamalloa, Arends, Boon, & Verstraete, 2013). An alternative configuration is to use BES as a polishing stage to AD where they remove low strength effluent from digesters (T. H. Pham et al., 2006). More recently, it was suggested that BES could be used to remove accumulating compounds from digesters, such as propionic acid, which could have inhibitory effects on AD operation (Hari, Katuri, Gorrion, Logan, & Saikaly, 2016a). By integrating BES with other technologies, such as anaerobic digestion and pretreatment, it could be possible to treat wastewater to the same standard as aerobic treatment *without* requiring oxygenation. Anaerobic treatment provides alternative electron sinks to products like water or hydrogen. In addition, these systems will generate energy that offset the energy requirements for treatment facilities.

The primary goal of this study was to investigate a laboratory scale wastewater treatment configuration, using AD, PT, and MECs, to evaluate a net-energy positive alternative to aerobic treatment. The configuration used in this study (Figure 6) was designed to prioritize the synthesis of hydrogen gas over biogas. This study was carried out in collaboration with the ORNL Wastewater Treatment Facility, which operates at roughly 0.3 million gallons per day (MGD). In our experiment, the incoming wastewater was processed to separate the insoluble, or particulate COD, from the soluble COD in the wastewater. The initial soluble fraction was fed into the MEC, with a 1:1 ratio of growth media, as a recirculating media. The initial insoluble fraction was concentrated to 1% total solids (TS) and pretreated using established methods: alkaline and thermal hydrolysis. The pretreated solids were processed again to separate the treated soluble phase from the insoluble treated phase. The soluble treated phase was added continuously as substrate in the MECs, whereas the insoluble fraction was anaerobically digested to produce biogas and volatile fatty acids (VFAs). The AD effluent was collected and used as a secondary MEC substrate. The AD effluent composition was expected to be rich in acetate, the primary intermediate between fermentation and methanogenesis, but may also contain longer chain organic acids, like propionate and butyrate, and alcohols, like ethanol (Dolfing, 2014; Hari, Katuri, Gorrion, Logan, & Saikaly, 2016b).

Scientific Methods

Wastewater Collection and Fractionation

Raw wastewater was collected from the Oak Ridge National Laboratory (ORNL) Wastewater Treatment Facility (WWTF). The collected wastewater was sourced from a pipe before the wastewater entered an aerobic digester. An initial 24 hour settling period took place at the WWTF using a large 15-gallon Igloo cooler. Roughly 1 gallon of settled solids and soluble phase wastewater was collected for further separation. The former is referred to as insoluble sludge phase and the latter as soluble phase. The retained wastewater was centrifuged using an Allegra X-15R (Beckman Coulter, USA) at 4700 rpm for 15 minutes to separate the insoluble sludge phase from the soluble water phase. The soluble phase was stored for use in MEC experiments. The sludge was re-suspended using growth media to a concentration of roughly 2% TS. The growth medium for the experiments contained a sterile salts solution comprised of 0.31 g NH₄Cl, 0.13 g KCl, 4.97 g NaH₂PO₄·H₂O, and 2.75 g Na₂HPO₄·H₂O per liter of nanopure water, 12.5 mL of filter sterilized Wolfe's mineral solution and vitamin solution and was adjusted to pH 7.0 with 1N NaOH prior to sterilization (Borole, Hamilton, Vishnivetskaya, Leak, Andras, et al., 2009). This centrifuge protocol was used for all sludge samples to separate the soluble water phase from the insoluble phase. Before HPLC analysis, liquid samples were further centrifuged

using a Biofuge Pico (Sorvall, USA) at 13,000 rpm for 5 minutes and then filtered using a 0.2 μm filter (Pall Corporation, USA).

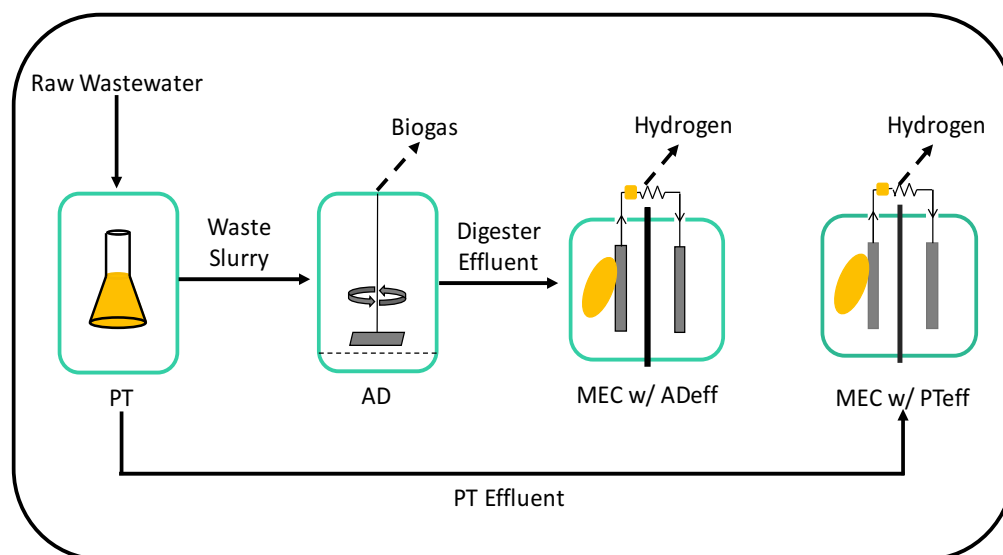

Figure 6. Schematic of combined ADMEC System with Pretreatment Stage. Raw wastewater was concentrated to 1% TS and pretreated. The soluble and insoluble fractions were separated and fed into subsequent biological reactors.

Pretreatment Protocol

Alkaline pretreatment was carried out by adding 3M NaOH to 1 liter of untreated sludge, described above. A preliminary experiment indicated that an alkaline treatment regime at a pH of 13 would yield a high degree of solubilization of COD (Figure 7). NaOH was added to the sludge, whereupon it was set on a shaker in an incubator set to room temperature (25°C) for 30 minutes. To neutralize the alkaline-treated sludge, 1M HCl was added until the pH reached 7. The thermal hydrolysis pretreatment process was carried out in an autoclave (Steris, USA) using a Liquid-60 cycle, which raised the temperature of the sample 121°C and 18 psi for 60 minutes.

Anaerobic Digester Setup and Operation

Duplicate anaerobic digestions were carried out in 160 mL serum bottles for control, alkaline, and thermal hydrolysis pretreatment experiments. The digesters were inoculated by a seed culture from an anaerobic digester at the Kuwahee Wastewater Treatment Plant in Knoxville, TN and was conditioned with wastewater solids from the ORNL Wastewater Treatment Plant, according to Latif et al 2015 (Latif, Mehta, & Batstone, 2015). The insoluble fractions of pretreated and untreated sludge were fed into the digesters and maintained with a hydraulic retention time (HRT) and solids retention time (SRT) of 20 days. The characteristics of these sludges are presented in Table 5. Each digester was fed three times a week, on Monday, Wednesday, and Friday. On Monday and Wednesday, the reactors received 10 mL of solids and on Friday, the reactors received 15 mL of solids. During these times, the reactors were also evaluated for biogas production by cumulative gas flow meter (Aalborg, USA), biogas composition by gas chromatography (Thermo Scientific, USA and Hewlett Packard, USA), and pH (Fisher Scientific, USA).

Microbial Electrolysis Cell Start-Up & Operation

The MECs used in these experiments were flat-plate type reactors made from PVC and have an anode volume of 15.96 mL (Borole, Hamilton, & Vishnivetskaya, 2011). The configuration is shown in Figure 7. The MECs used in these experiments were inoculated by an acetate-fed MEC that has been operating for over one year. This inoculum was co-inoculated with activated sludge from the Kuwahee Wastewater Treatment Plant. After a few days, the MEC was flushed with fresh medium to remove the sludge and planktonic cells in the anode, as described by (Borole, Hamilton, et al., 2011). The MECs were then enriched using a combined 12.5 g/L glucose, 10 g/L acetate, 2.5 g/L propionate solution until the experiments began. Glucose was added to enrich for a variety of microbes that can convert its fermentation products such as organic acids and alcohols that may be produced by an anaerobic digester (Borole & Mielenz, 2011; Freguia et al., 2008). The glucose concentration was reduced over time to growth of exoelectrogens and prevent the growth of hydrogenotrophic methanogens, since glucose can also produce hydrogen. The anode material was a carbon felt and the cathode material was a platinum-deposited carbon interfaced with a stainless-steel mesh. A carbon rod and a stainless-steel wire were used as current collectors for anode and cathode, respectively. A Nafion proton exchange membrane was used to selectively permit protons to pass from the anode to the cathode. Wastewater medium was fed into the anode chamber at a rate of 4 mL/min. This medium cocktail was mixed 1:1 with the raw wastewater soluble phase collected from the primary settling of the wastewater. The anode was poised at a potential of -0.2 V vs. Ag/AgCl using a potentiostat (Bio-Logic Knoxville USA). The potentiostat was operated in Chronoamperometry mode recording the current produced by the system. The batch experiments were run until the produced current dropped below 1 mA, which corresponded to the hydrogen production becoming negligible. Batch experiments were conducted to compare the effects of pretreatment on the AD effluent and the aqueous phase extracted from the pretreatment stage. In each batch test, roughly 0.2 g/L COD equivalent of substrate was added to the 250 mL media bottle. Before each batch test, the MECs were fed continuously with an acetate, glucose, propionate solution for roughly 24 hours. Immediately before the batch experiment, the cathode buffer solution was replaced with fresh buffer, the entire anode substrate loop was flushed with fresh media, and the entire system was sparged with nitrogen gas.

Table 5. Sludge Characteristics Before and After Pretreatment

Sample	ABS. TCOD	TCOD Conc. (g/L)	ABS. SCOD	SCOD Conc. (g/L)	SCOD %	DD COD (%)
Control Before	0.556	13.30	0.182	1.74	13.09	-
Control After	0.621	14.85	0.182	1.74	11.72	0
Alkaline	0.817	19.54	0.654	6.26	32.02	25.37
Thermal	0.763	18.25	0.523	5.00	27.42	19.76

Analysis and Calculations

Gas Chromatography Analysis

The gas composition from each digester was measured using two GC instruments (Thermo Scientific, USA and Hewlett Packard, USA). A Thermo Scientific Focus GC uses a Megabore Molesieve 5A column, used to measure H₂, O₂, N₂, and CH₄ gases with Helium as a carrier gas. The method was run at 35 C and was ramped up to 80°C. A Hewlett Packard 5890 Series II GC using a HP-PLOT 19095P column was used to measure N₂/O₂, CH₄, CO₂, and CO using Helium as a carrier gas. The method was run at 26°C and was ramped up to 45°C.

High Performance Liquid Chromatography Analysis

Liquid digester effluent, pretreatment effluent, and sludge samples were taken for HPLC analysis. The samples were acidified by adding 1.75 ul of 2M H₂SO₄ to 250 ul samples and run on a Hitachi HPLC system using 5 mM H₂SO₄ as the mobile phase. Standards were prepared for formic acid, propionic acid, valeric acid, isovaleric acid, butyric acid, and acetic acid. The concentration of organic acids in the MEC experiments were too low to be determined so only the COD values will be used in those experiments.

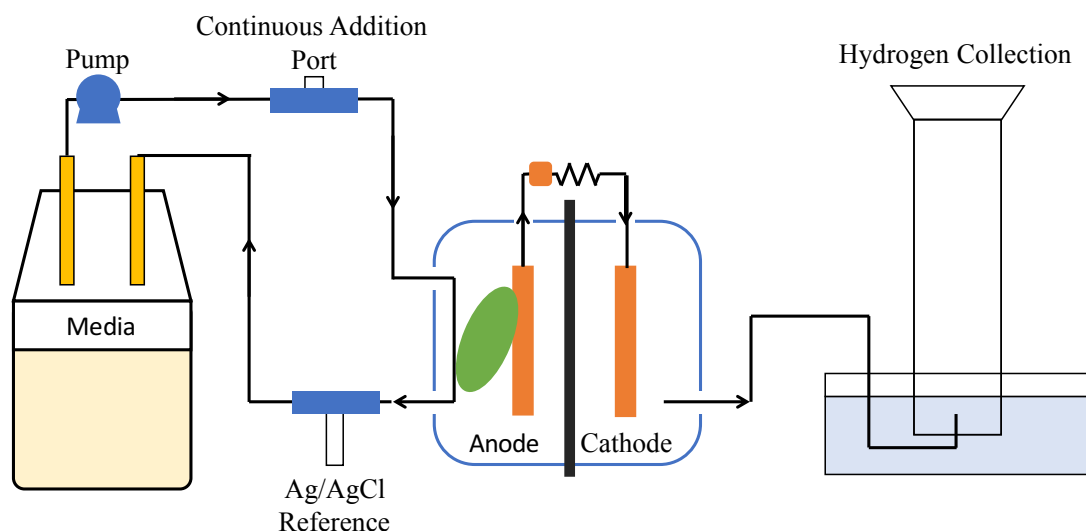

Figure 7. Microbial Electrolysis Cell Set-up

Alkalinity and pH

Alkalinity was measured using a two-point acid titration. The volume of 1M HCl added to reduce the pH of sludge sample from 5.75 to 4.0 was used to calculate the alkalinity of sludge (APHA/AWWA/WEF, 2012). The pH for each digester was measured after gas sampling using a Fisher Scientific Acumen AB15 Plus pH probe. 3M NaOH was used to adjust the digester pH to 7 at the time of each sampling.

Total and Volatile Solids Analysis

Total and Volatile solids were determined using standard methods, APHA 2450 B & E. Total solids were dried in an oven set at 105°C for 6 hours (APHA/AWWA/WEF, 2012). Volatile solids were dried in an oven set to 550°C for 1 hour.

COD Analysis

Total and soluble COD samples were measured for raw sludge, treated sludge, and digester effluents. Total COD samples were sonicated for 1 hr to homogenize the samples and were diluted 1:10 in COD vials (Hach Loveland, CO USA). Soluble COD samples were centrifuged, as mentioned above, and were diluted 1:4 in COD vials. Total absorbance of COD samples was determined in a spectrophotometer at 620 nm. A calibration curve was used to determine the concentration of COD from total absorbance. %SCOD is the percent of soluble COD compare to total COD and DD COD is the degree of COD solubilization (Eq 31.).

Calculations and Performance Analysis

Digester performance was monitored by GC analysis for oxygen, nitrogen, methane, carbon dioxide, and hydrogen, production of biogas using a cumulative gas analyzer, pH, and VFAs by HPLC. The specific methane production rate was determined for each experimental group by comparing the COD added to biogas production after the reactors reached steady state (Eq 26).

$$\text{Eq. 26} \quad \text{Specific Methane Yield} = \frac{\text{mL CH}_4}{\text{gCOD} \cdot \text{day}}$$

The coulombic efficiency (CE), cathodic conversion efficiency (CCE), hydrogen efficiency (HE) and hydrogen production rates were calculated for MECs using each substrate (Eq 27-30). Coulombic efficiency is the observed coulombs divided by the theoretical coulombs generated from conversion of the substrate. Cathodic conversion efficiency is the actual moles of hydrogen gas produced divided by the theoretical moles of hydrogen produced from current production in the anode. Hydrogen efficiency is the calculated by dividing the moles of hydrogen produced by the theoretical moles of hydrogen generated from conversion of the substrate, which is twice the moles of electrons generated from the substrate. Hydrogen production rate is the volume of hydrogen gas produced divided by the anode volume and the duration of the experiment.

$$\text{Eq. 27} \quad \text{Coulombic Efficiency} = \frac{I_{\text{obs}} \cdot \text{time}}{\eta_s \cdot \eta_e F}$$

$$\text{Eq. 28} \quad \text{Cathode Conversion Efficiency} = \frac{\frac{P \cdot V_{\text{H}_2}}{R \cdot T}}{C_{\text{obs}} \frac{F}{F \cdot \eta_e}}$$

$$\text{Eq. 29} \quad \text{Hydrogen Efficiency} = \frac{\frac{P \cdot V_{\text{H}_2}}{R \cdot T}}{2 \cdot \eta_t}$$

$$\text{Eq. 30} \quad \text{Hydrogen Production Rate} = \frac{V_{\text{H}_2}}{\text{Vol}_{\text{anode}} \cdot \text{time}}$$

The pretreatment tests were evaluated based on the increased solubility of COD after pretreatment. Before and after samples were acquired for COD analysis and COD solubilization calculations (Eq 31). These methods were based on the preliminary data (Figure 20). Where sCOD is soluble COD after pretreatment, sCOD₀ is the initial soluble COD before pretreatment, and TCOD is the total COD before pretreatment.

$$\text{Eq. 31} \quad \text{COD solubilization} = \frac{\text{sCOD} - \text{sCOD}_0}{(\text{TCOD}_0 - \text{sCOD}_0)}$$

COD Mass Balance and Electron Equivalence Analysis

The objective of this analysis was to determine the flux of electrons from the starting substrate to the end products, which included methane, hydrogen, cellular biomass and unconverted substrate. A COD mass balance was constructed to compare the flux of electrons between control experiments and the pretreatment experiments. This was done on the basis of evaluating 1 gram of sludge COD before pretreatment. Each process contains four components: Pretreatment, Anaerobic Digestion, Microbial Electrolysis of Digester Effluent, and Microbial Electrolysis of Pretreatment soluble phase. In each component, where appropriate, the COD sinks were evaluated for soluble COD, particulate COD, methane, biomass, and electrons. The methane contribution was evaluated by comparing the observed methane production to the theoretical methane yield (350 mL CH₄/gCOD) (E. S. Heidrich et al., 2011) The COD lost to biomass growth was accounted for using determined rates for: *G. sulfurreducens* ($f_s=0.05$) (Bond & Lovley, 2003; Esteve-Núñez, Rothermich, Sharma, & Lovley, 2005), fermenters ($f_s=0.1$) (Rittmann & McCarty, 2001), and acetogens/homoacetogens ($f_s=0.1$) (Bainotti & Nishio, 2000; Tschek & Pfennig, 1984). The biomass fractions for AD and BES growth used in this study were 28% and 5%, respectively.

Energy Production Comparison

The hydrogen and methane produced in each process were accounted for and normalized to Joules/g COD Fed. The normalization based on COD accounts for the differences in digester substrate composition after pretreatment. The heating value of methane used in this analysis was 52.5 MJ/kg and the heating value of hydrogen was 131MJ/kg. The sum of energy generated from Anaerobic Digestion and the two Microbial Electrolysis stages were evaluated for the six experimental groups: Control Replicate 1 (C1), Control Replicate 2 (C2), Alkaline Replicate 1 (A1), Alkaline Replicate 2 (A2), Thermal Replicate 1 (T1), and Thermal Replicate 2 (T2).

Results

Effects of Pretreatment on Soluble COD

In a preliminary experiment, four alkaline pretreatment experiments and three autoclave cycle experiments were investigated for their effects on solubilizing COD in 1% sludge. These were carried out in 160 mL serum bottles. Notably, the alkaline treatment at pH 13 and the liquid 60 autoclave cycle demonstrated the highest effect on COD solubilization (Figure 20). These pretreatment experiments were repeated for larger volumes (800 mL of sludge) to treat sludge needed for anaerobic digester experiments. The control showed no change in sCOD. The alkaline and thermal pretreatment methods increased sCOD by 25% and 20%, respectively. These results are shown in Figure 8 and are very similar to our preliminary results. The lower COD solubilization in the thermal pretreatment group was likely a result of poor mixing in the vessel during autoclaving. The soluble phase of treated and non-treated sludge was separated and stored for later use in MEC experiments. The insoluble sludge was diluted to roughly 1% total solids using growth media.

Influence of Pretreated Sludge on Anaerobic Digestion

In most studies using pretreatment to enhance biogas production in anaerobic digesters, the soluble fraction of COD remained in the digesters. However, the goal of this study was to improve the electron flux to hydrogen gas, via microbial electrolysis. As such, the soluble fraction of COD was removed from the sludge before being anaerobically digested. Even with

the removal of the soluble fraction of COD, the pretreatment of insoluble sludge led to noticeable changes in anaerobic digestion. It is important to note that the initial COD concentrations for each sludge were different and these values varied over the course of the experiment, which is a natural consequence of using real wastewater.

The first noticeable impact of pretreatment on AD was on the biogas composition. The methane fraction of biogas in the control group was below $50.26 \pm 0.53\%$ throughout the experiment. The maximum methane fractions in the alkaline and thermal pretreatment groups were $78.29 \pm 2.89\%$ and $73.2 \pm 1.79\%$, respectively. These results are shown in Figure 9. High error recorded for the Alkaline reactors on Day 7 was the result of one reactor not producing a measurable amount of biogas. Similar impacts of pretreatment on biogas composition have been observed previously (Zhen, Lu, Li, & Zhao, 2014). It was observed by Penaud that the addition of pretreatment stages can increase the biodegradability of sludge, which may have improved the production of methane in digesters with treated sludge (Penaud et al., 1999).

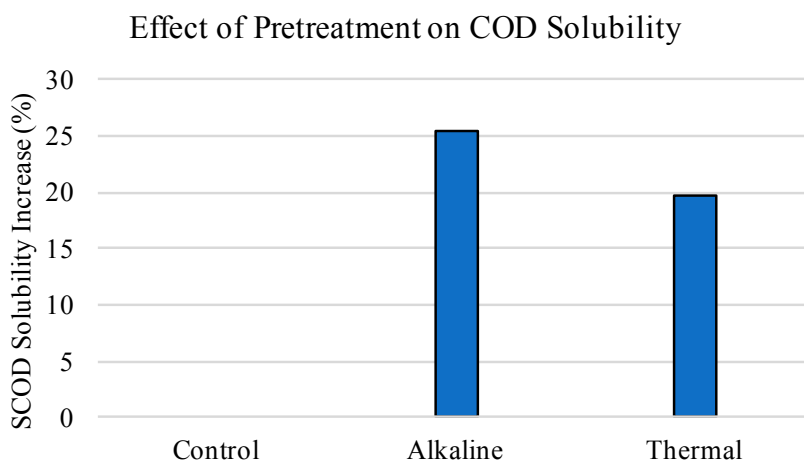

Figure 8. Effects of Alkaline and Thermal Hydrolysis Pretreatment on soluble COD in laboratory 1-L tests

Influence of Pretreated Sludge on Anaerobic Digestion

In most studies using pretreatment to enhance biogas production in anaerobic digesters, the soluble fraction of COD remained in the digesters. However, the goal of this study was to improve the electron flux to hydrogen gas, via microbial electrolysis. As such, the soluble fraction of COD was removed from the sludge before being anaerobically digested. Even with the removal of the soluble fraction of COD, the pretreatment of insoluble sludge led to noticeable changes in anaerobic digestion. It is important to note that the initial COD concentrations for each sludge were different and these values varied over the course of the experiment, which is a natural consequence of using real wastewater.

The first noticeable impact of pretreatment on AD was on the biogas composition. The methane fraction of biogas in the control group was below $50.26 \pm 0.53\%$ throughout the experiment. The maximum methane fractions in the alkaline and thermal pretreatment groups were $78.29 \pm 2.89\%$ and $73.2 \pm 1.79\%$, respectively. These results are shown in Figure 9. High error recorded for the Alkaline reactors on Day 7 was the result of one reactor not producing a

measurable amount of biogas. Similar impacts of pretreatment on biogas composition have been observed previously (Zhen et al., 2014). It was observed by Penaud that the addition of pretreatment stages can increase the biodegradability of sludge, which may have improved the production of methane in digesters with treated sludge (Penaud et al., 1999).

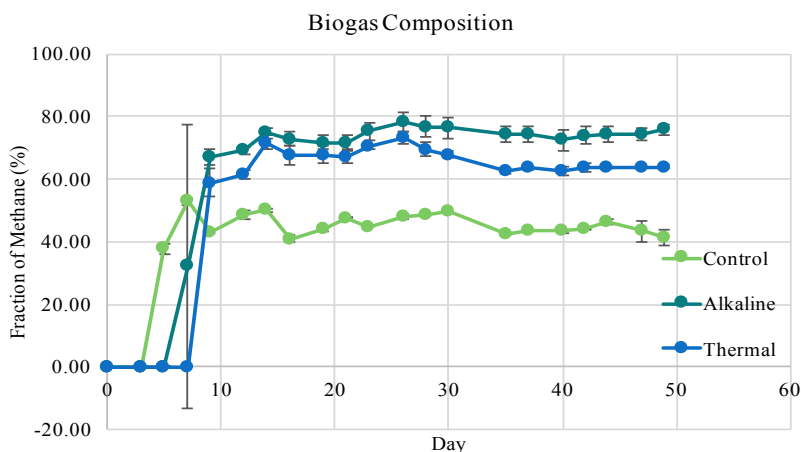

Figure 9. Effect of Sludge Pretreatment on Methane Composition

The specific methane production was another noticeable factor that was influenced by pretreatment. In the experimental groups where pretreatment was conducted prior to digestion, the total COD available in the digesters was reduced due to COD solubilization during pretreatment. As such, the biogas production and methane production in treatment groups were lower than the control group, shown in Figure 10. The volume of methane produced is much greater in the control group, even with the low methane fraction discussed above. The control produced 80 mL CH₄/gCOD*d on average, compared to 20 and 30 mL CH₄/gCOD*d, for alkaline and thermal pretreatment, respectively. The variations in methane production are mostly due to changes in sludge concentrations and extended digestion durations over the weekend, i.e. samples taken on Wednesday and Friday evaluated two days of digestion whereas samples taken on Monday evaluated three days of digestion. This can be seen in the small bumps throughout Figure 9 and 10. Although not present in Figure 10, the organic loading rates for the reactors was changing over time. This was partly due to the changing concentration of COD in the raw wastewater but also due to the extraction method use to feed the digesters. Larger flocs of insoluble sludge often clogged the feeding device and remained in the substrate container, slowing increasing the total COD concentration. The general trend was an increase in COD over time for both alkaline and thermal groups. With this trend, the methane production is inversely proportional to the COD loading rate. In these experiments, the pH was recorded and manually adjusted to remain at 7. At no point during the experiment did the pH drop below 6.5. As such, pH was not perceived as a significant factor in biogas production.

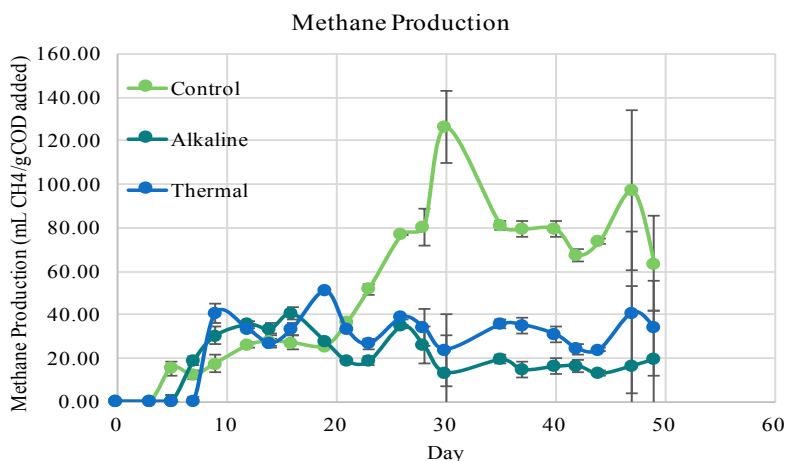

Figure 10. Specific methane production for Anaerobic Digesters

The organic acid composition in the digester effluent for each group was characterized on a weekly basis to evaluate the general performance of the system. A snapshot of the organic acid profile in the control, alkaline, and thermal digesters is presented in Figure 11. In each reactor, acetate and propionate are the most abundant acids. The accumulation of organic acids in each reactor suggests some imbalance in microbial activity between fermenters and archaea. To alleviate this problem, other researchers have implemented electrode-based biofilms within the digester vessel to consume accumulated organic acids (Koch et al., 2015; B. Tartakovsky et al., 2011; Boris Tartakovsky et al., 2014). In our configuration, the accumulation of organic acids was desirable, especially in this scenario when acetate and propionate are the dominant acids. Several studies have investigated BES systems fed with pure substrates of acetate and propionate. It is well known that acetate can be directly oxidized by electrogenic bacteria. However, the mechanisms of propionate oxidation are unclear. Hari et al, investigated the oxidation of propionate and proposed two mechanisms: 1) direct oxidation by electrogens or 2) indirect oxidation after propionate is fermented to acetate and subsequently oxidized by electrogens (Hari et al., 2016a). In the next stage of this experiment, pure substrates of acetate and propionate were investigated as controls and compared to AD and PT soluble fractions.

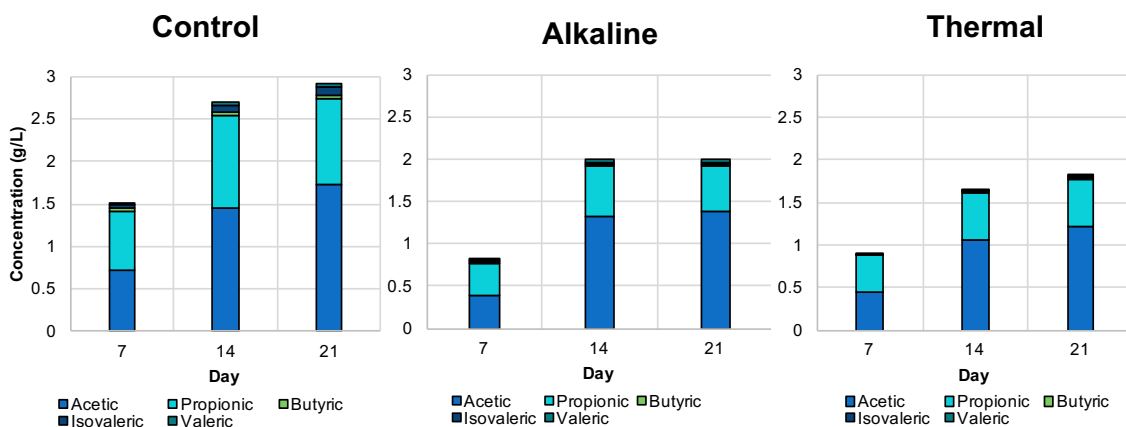

Figure 11. Organic Acid Profile in Digester Effluent during Startup

Effects of Pretreatment in MECs

The remaining experiments were conducted using duplicate microbial electrolysis cell (MEC) reactors. In the first experiment, the soluble fraction of anaerobic digester effluent was fed in batch into the MECs at a concentration of 0.2 g-COD/L. These experiments were carried out for roughly 24 hours, or until the current dropped below 1mA. In the second experiment, the soluble fraction from the pretreatment vessels was fed in batch into the MECs under the same conditions as above.

MECs fed with Anaerobic Digester Effluent

Hydrogen production values from MEC reactors fed with digester effluent are shown in Figure 12. The controls using pure substrates of acetate and propionate demonstrated hydrogen production rates of 5.79 ± 0.03 L-H₂/L*d and 3.49 ± 0.10 L-H₂/L*d, respectively. By contrast, the hydrogen production in MECs fed with digester effluent did not exceed 2 L-H₂/L*d. The thermally pretreated substrates demonstrated hydrogen production of 1.7 ± 0.2 L-H₂/L*d. The control and alkaline pretreated substrates demonstrated hydrogen production on the order of 0.29 ± 0.1 L-H₂/L*d, and 0.3 ± 0.1 L-H₂/L*d, respectively.

A more detailed look at the electrochemical performance in these systems highlights the differences in hydrogen production, shown in Figure 13. The thermally pretreated substrates demonstrated consistently high coulombic efficiencies (>40%) but also showed relatively high cathode conversion efficiencies and overall hydrogen efficiencies. By contrast, the control and alkaline pretreated substrates had low and variable coulombic efficiencies (5%-65%) and poor cathode and hydrogen efficiencies (<10%). Chronoamperometry data from these experiments show that the current production in the control and alkaline groups peaked shortly after the experiment began and quickly dropped below 1mA, which cannot supplement hydrogen production. The current production profile in thermal groups were different in that the current exceeded 1mA for a longer period of time, leading to higher hydrogen production rates and higher efficiencies (Figure 21).

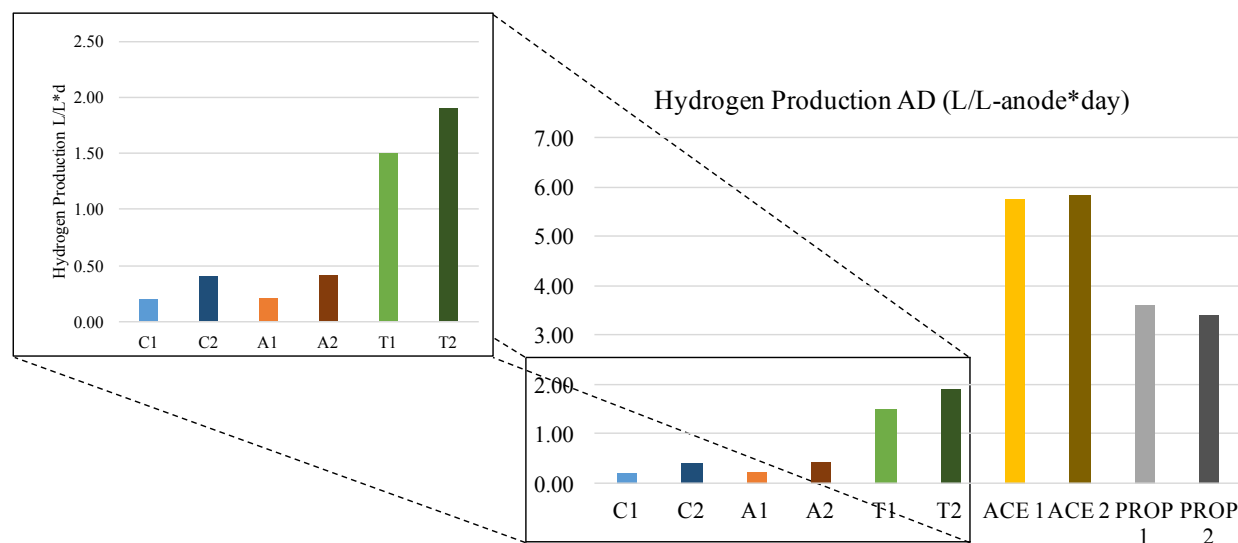

Figure 12. Hydrogen production rates in MECs fed with AD effluent and Control Runs. ACE and Propionate groups are control runs with 0.2 gCOD-eq/L.

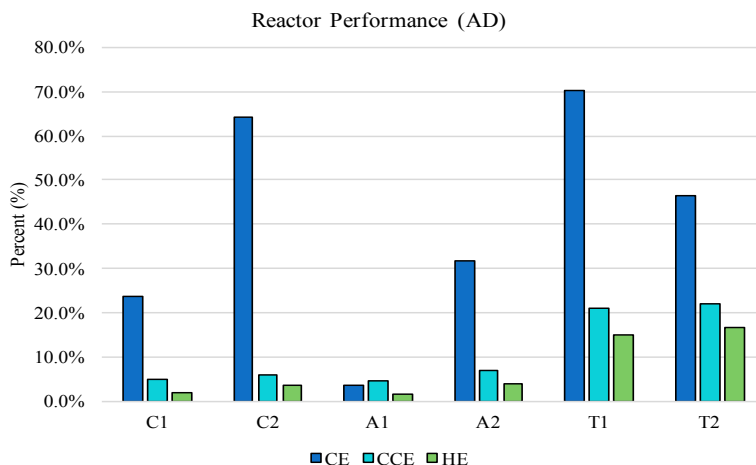

Figure 13. Reactor performances in MECs fed with AD effluent. CE, CCE, and HE are Coulombic Efficiency, Cathode Conversion Efficiency, and Hydrogen Efficiency, respectively

MECs fed with Pretreatment Effluent

Hydrogen production rates from MEC reactors fed with pretreatment effluent are shown in Figure 14. Although the composition of the pretreatment effluent was undetermined, HPLC results showed that this substrate was not rich in organic acids. As such, the soluble COD in these substrates were somewhat recalcitrant and likely required intermediate fermentation and hydrolysis by synergistic bacteria before electrogens could directly oxidize the organic acids. This hypothesis seems to be supported by the data in this experiment. All the experimental groups in this test had hydrogen production rates below 0.6 L-H₂/L*d. However, both pretreated substrates demonstrated slightly higher hydrogen production rates than the control, 0.47 ± 0.11 L-H₂/L*d for thermal, 0.51 ± 0.03 L-H₂/L*d for alkaline, and 0.27 ± 0.001 L-H₂/L*d for control, respectively. These results suggest that pretreatment could have increased the biodegradability of COD in these substrates, even though it did not directly lead to organic acid production.

The electrochemical performance in these reactors was different than the digester effluent tests, shown in Figure 15. Due to the complex nature of the substrates in these experiments, the coulombic efficiencies were on average very low, compared to AD effluent as a substrate. The high CE for the Control 1 experiment is likely an artifact of error from COD analysis, as the basis for CE is the consumption of COD. In addition, the electrons released during the oxidation of COD could be converted to hydrogen at relatively low efficiencies. Overall, the hydrogen efficiencies for all reactors were low (<2%). The current production profiles from chronoamperometry were similar in that they all exhibited a sharp peak in current early on and then quickly dropped below 1 mA (Figure 21).

In general, the COD effluent concentrations from the MECs were greater than the secondary water treatment standards set by the EPA. The 30-day average for BOD concentrations in the secondary wastewater effluent must be below 30 mg/l (US EPA, 2017). The relationship between BOD and COD has been estimated by a ratio of 0.5, previously (Hays et al., 2011). In this study, the effluent concentrations were above 150 mg BOD/l from MECs fed with digester effluent and pretreatment substrate (Data not shown).

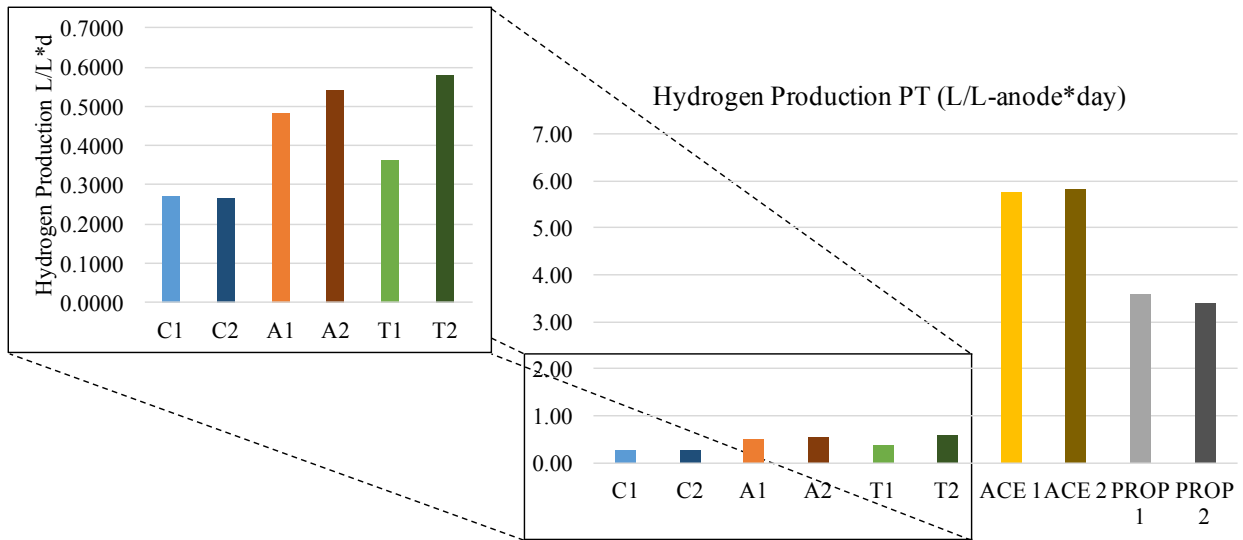

Figure 14. Hydrogen production rates in MECs fed with PT effluent. ACE and Propionate groups are control runs with 0.2 gCOD-eq/L

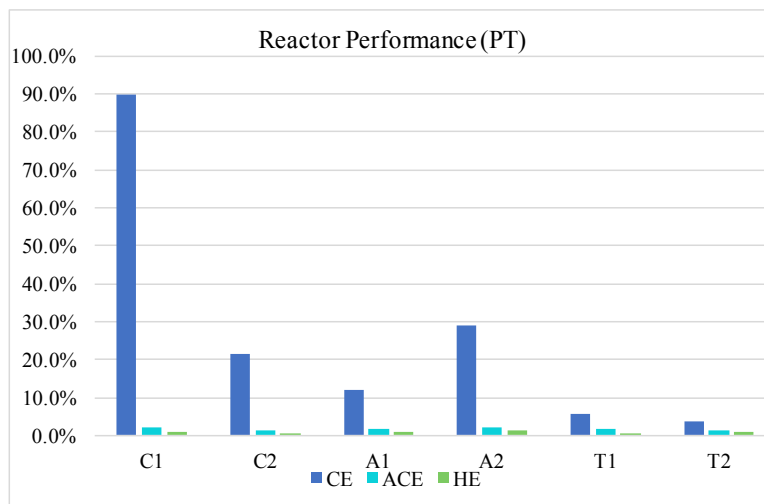

Figure 15. Reactor performances in MECs fed with PT effluent. CE, CCE, and HE are Coulombic Efficiency, Cathode Conversion Efficiency, and Hydrogen Efficiency, respectively

COD-electron Balance

To evaluate our hypothesis that PT combined with our ADMEC system would increase the flux of electrons to hydrogen production, a COD balance was performed to look at electron sinks. To evaluate each system, 1 gram of COD sludge was theoretically tracked in our system. The electron sinks, i.e. methane, microbial biomass, particulate sludge, soluble sludge, and electrons were determined for each system. Other electron sinks that were not calculated were summed as Residual. It is also important to note that a small amount of COD was added to the MECs in the form of media, but this had little effect on the results. Notable differences between the systems were highlighted in red. The first noticeable difference is that the soluble fraction of COD after pretreatment is higher in the alkaline and thermal groups (see previous section). In the anaerobic digestion stage, it can be observed that the methane and biomass sinks are higher in the control system than the alkaline and thermal systems (see section on AD). Methane sinks in AD were 20%, 4% and 7% for control, alkaline, and thermal groups. Biomass was estimated by the theoretical fraction of COD converted to microbial growth and remain one of the largest COD sinks in each system (Bainotti & Nishio, 2000; Bond & Lovley, 2003; Esteve-Núñez et al., 2005; Rittmann & McCarty, 2001; Tschech & Pfennig, 1984). For the MEC experiments, the higher soluble COD fractions fed into the MECs yielded a greater potential for hydrogen production in this configuration. In the AD effluent experiments, the electron yield was $12 \pm 4\%$, $4 \pm 3\%$, and $8 \pm 3\%$ for thermal, alkaline, and control groups. The thermal group also consumed the most soluble COD, whereas the control and alkaline groups consumed less. The alkaline group had $19 \pm 3\%$ soluble COD remaining in the MEC effluent. Ultimately, with increased optimization in the MECs, higher hydrogen production efficiencies would lead to greater electron fluxes to hydrogen gas. In this study, the soluble COD was not effectively oxidized in the alkaline and thermal reactors when fed with pretreatment substrate, leading to higher effluent COD concentrations. Overall, this COD balance suggests that the ADMEC platform with PT could be optimized for increased hydrogen production from wastewater solids.

Energy Production from ADMEC Systems

After determining the COD balance, the next step is to look at how the conversion of COD into energy occurred in the system. A summary of this data is in Table 21 in the appendix. The overall energy production of methane gas and hydrogen gas were determined based on average heating values. In general, the energy production from methane was greater in the control system than the pretreated systems, even when accounting for the differences in soluble COD. This is consistent with the COD balance results in Figure 16. The energy recovered from biogas was $2,397 \pm 0.0$ J/g COD for the control, 468 ± 0.0 J/g COD for alkaline pretreatment, and 830 ± 0.0 J/g COD for thermal pretreatment. The energy recovery from microbial electrolysis of pretreatment effluent was similar for all experimental groups, however both reactors fed with treated effluent produced more energy. The alkaline and thermal reactors produced 246 ± 22 J/g COD and 214 ± 82 J/g COD, compared to 68 ± 14 J/g COD for the control. The pretreatment effluent showed to be an ineffective substrate for microbial electrolysis, as evident in the COD balance and other results. The major difference in this study came from hydrogen gas production during the microbial electrolysis of digester effluent (Figure 17). MECs fed with control and alkaline digester effluent produced 234 ± 53 J/g COD and 313 ± 140 J/g COD, compared with $1,422 \pm 82$ J/g COD in the thermal digester effluent group. By adding the total energy produced from each system, the real impact of pretreatment in this experiment can be observed. Compared to the control systems, which produced on average $2,699 \pm 38$ J/g COD, alkaline pretreatment

had a net negative impact on energy production, $1,028 \pm 162$ J/g COD. In contrast, thermal pretreatment had a neutral impact on energy production, $2,466 \pm 36$ J/g COD. Note that these calculations did not include the energy required to supply an external voltage for the MECs. From these results, thermal pretreatment had a significant effect on MEC performance compared to the control and alkaline groups. However, AD produced more energy from control sludge than any other process. Collectively, the control group demonstrated the highest energy recovery, thermal pretreatment was slightly lower than the control, and alkaline pretreatment had a net negative impact.

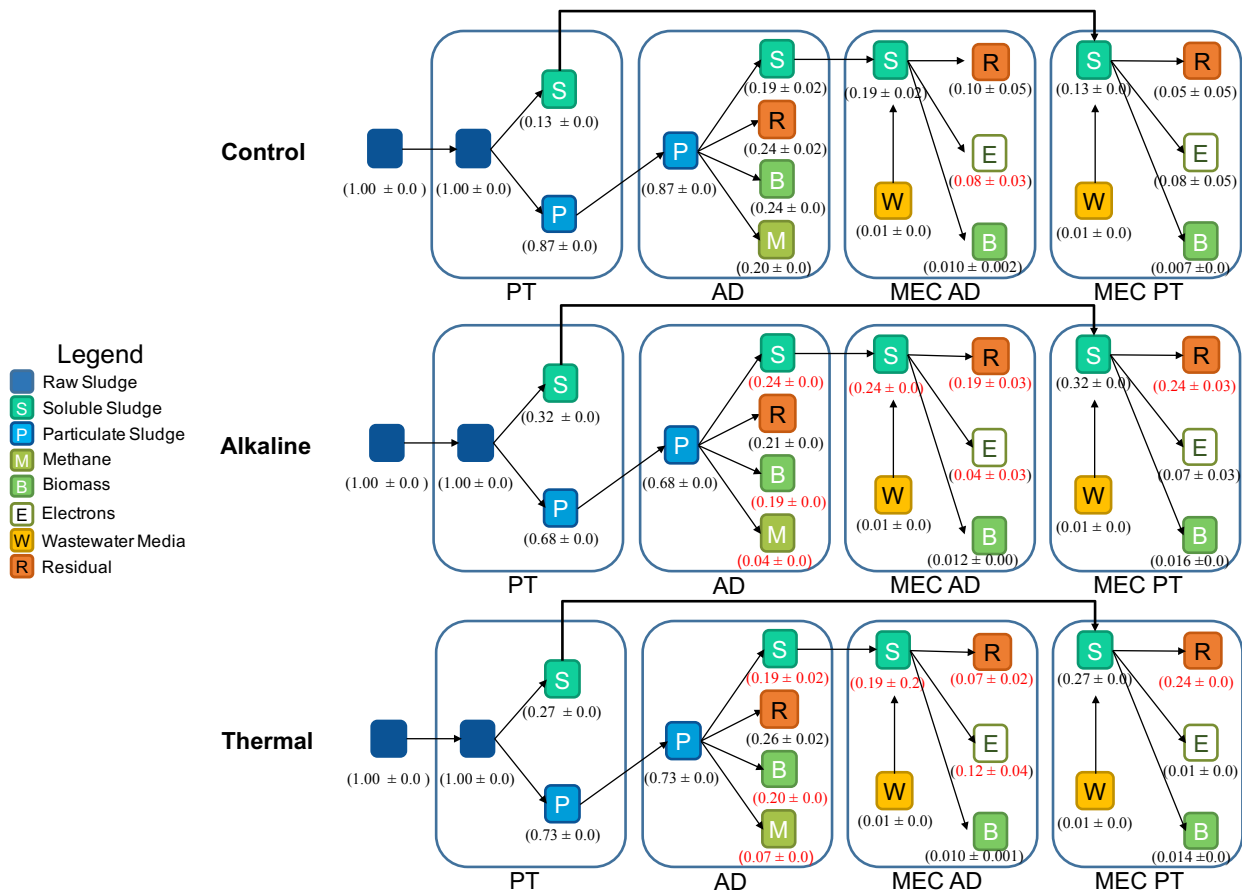

Figure 16. COD Balance for Control, Alkaline, and Thermal Experiment Groups

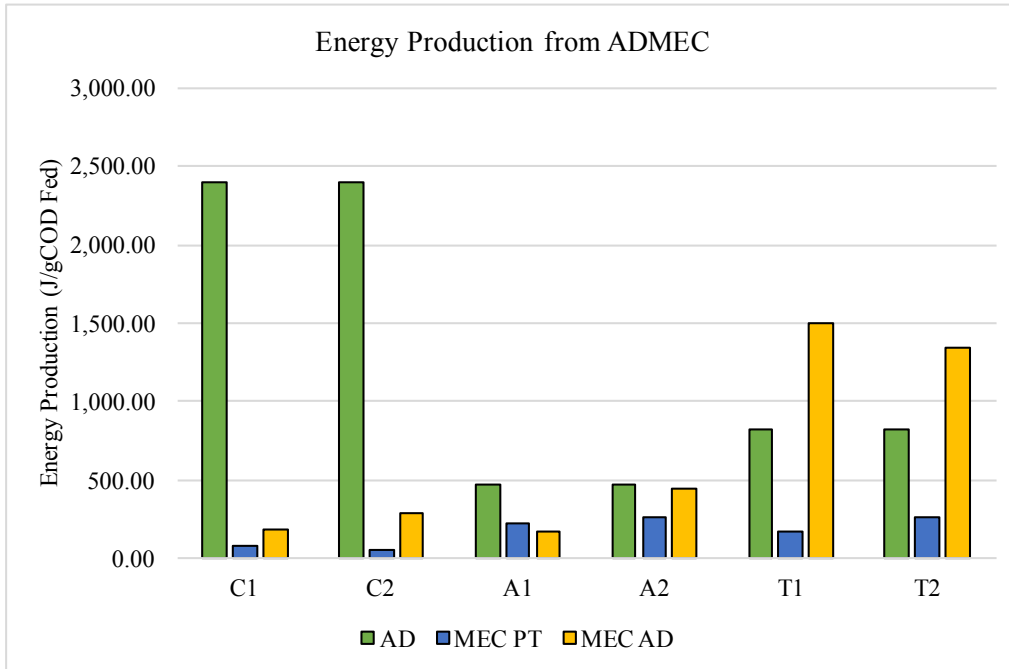

Figure 17. Energy Produced per gram of COD added per day. Energy from methane during anaerobic digestion (Green), hydrogen gas from pretreatment effluent (Blue), and hydrogen gas from digester effluent (Yellow).

Discussion

Anaerobic digestion with pretreatment has been studied many times in recent decades to improve biogas production and sludge stability (Ariunbaatar et al., 2014; Bordeleau & Droste, 2011; Carrère et al., 2010; Penaud et al., 1999; Yu et al., 2014). With the recent development of bioelectrochemical systems, this technology can serve as a downstream polishing stage to digesters (T. H. Pham et al., 2006). BES have the added benefit of operating at high efficiencies and can produce high-value products, like hydrogen gas. Previously, our group published a study comparing the energy efficiencies, economic value, and environmental impacts of AD, microbial fuel cells (MFC), and MECs and identified the combined ADMFC system as the process with the highest potential (Beegle & Borole, n.d.) In this study, microbial electrolysis cells were used as a secondary treatment stage to anaerobic digesters using treated sludge, but an emphasis was given to hydrogen gas production instead of biogas production. To increase production of hydrogen gas via microbial electrolysis, all streams of soluble COD were directed to MECs. As discussed above, this treatment process resulted in increased soluble COD after pretreatment and had varying effects on anaerobic digestion. The methane composition in digester biogas was higher in groups using treated sludges. This trend has been observed in previous studies (Zhen et al., 2014). However, the methane production rates were lower in these experiment groups, likely because of removing the soluble COD from the influent stream. In addition, the organic loading rate affected biogas production. Increases in organic loading rates in anaerobic digesters resulted in lower methane production rates. All digesters had similar VFA profiles and accumulated acetic acid and propionic acid throughout the experiment, which are ideal for microbial electrolysis.

The soluble fractions of pretreated sludge and digester effluents were used separately as substrates for microbial electrolysis. Variations in the concentrations of organic acids (propionic acid and acetic acid) and the organic loading rates resulted in performance differences in the MECs. Hydrogen production was greater when anaerobic digester effluent was fed into the MECs, but this was likely due to a higher VFA concentration compared to pretreatment effluents. HPLC analysis of the liquid phase extracted from the pretreatment step did not detect any VFA's, which may explain why this substrate showed poor performance in the MEC. The pretreatment liquid fraction likely contained solubilized biomolecules other than organic acids, which the inoculum was enriched for, which may explain poor performance. The breakdown of complex substrates, like cellulose and wastewater streams, may require preliminary fermentation outside of the BES reactor or enrich for syntrophs that are capable of conversion (Kiely, Regan, & Logan, 2011). Retaining the soluble COD fraction after pretreatment for use in the digester may have improved the production of biogas and organic acids. A study at the University of Queensland looked at temperature and solids retention time as variables to control the microbial population and enhance VFA production (Vanwonterghem, Jensen, Rabaey, & Tyson, 2015). A similar approach can be taken with the operation of the digesters in this process to improve the flux of electrons toward hydrogen gas in the MEC stage.

This study only explored two potential pretreatment processes, alkaline and thermal hydrolysis. These methods were chosen because of their ease of application and low cost. However, further investigations into these methods and newer methods is necessary to improve the energy recovery from waste. The recalcitrant nature of complex waste streams typically requires some pretreatment stage to accelerate the hydrolysis and conversion of organic matter, improve dewatering, stabilize pathogens, and improve effluent quality (Bordeleau & Droste, 2011). An important variable moving forward is the specificity of pretreatment on specific

compounds in the wastewater, or other waste stream, that are desired for downstream biological processes. In this study, both pretreatment methods did not release or increase the concentration of VFA's in the effluent stream. The sCOD fraction likely consisted of carbohydrates and proteins. These effluent streams were fed into MECs which were not enriched to degrade complex organic compounds. A strategy to capitalize on the effects of pretreatment and the operation of a fermenter is to optimize the conversion of solubilized organics after pretreatment into short VFA's. This strategy could be coupled with methanogenesis inhibition methods, such as shorter HRT and the addition of chemical inhibitors, to increase VFA production (He Liu, Wang, Wang, & Chen, 2011; Vanwonterghem et al., 2015). Another important factor to monitor is the production of unwanted byproducts during pretreatment. In this experiment, the accumulation of NaCl salt after neutralization of the NaOH used in alkaline pretreatment likely inhibited the biological activity in the anaerobic digester and may have had negative impacts on MEC performance (Y. Chen, Cheng, & Creamer, 2008)

Another developing technology is the membrane bioreactor (MBR). The general concept is like conventional aerobic or anaerobic digestion but the effluent stream is passed through an internal or external filter to retain solids within the reactor. A major benefit of utilizing MBRs is that the HRT can be reduced from ~20 days for an anaerobic digester down to 8 hours. This will significantly reduce the reactor footprint, leading to lower capital and operational costs. Integrating membranes with small pore sizes can also be used to control and improve effluent quality. As reported in a previous study, anaerobic membrane bioreactors (AnMBRs) demonstrated higher energy recovery, economic benefits, and positive environmental impact compared to conventional high-rate AD, activated sludge with AD, and aerobic membrane bioreactors when fed with medium strength (430 mg/L) domestic wastewater (Smith et al., 2014). The primary barriers to MBR adoption are membrane fouling control and cost. The addition of a membrane provides a new surface for biofilms to attach and proliferate, eventually reducing the hydraulic flux of effluent out of the reactor. Several strategies have been investigated to control and reduce the instance of membrane fouling. The cost of maintaining an MBR reactor is related to the instances of fouling. Membranes are a significant component of the operating costs for an MBR. Developing strategies for long-term fouling control and reducing the costs of membranes could improve the rate of MBR adoption.

An additional route the integrated ADMEC process can follow is toward higher value products from MEC module. Hydrogen gas has been demonstrated as a product of microbial electrolysis with greater economic value than biogas or electricity. The fields of bioelectrochemistry and electro-fermentation are growing rapidly and the range of feasible products is growing. In 2011, Pant et al investigated the economic and environmental impacts of bioelectrochemical reactors synthesizing hydrogen peroxide in the cathode (Pant et al, 2011). The hydrogen peroxide could be used to supplement the chemical disinfection processes later in the water treatment process but also reduce environmental impacts associated with hydrogen peroxide synthesis in other industries. Other MEC studies have produced products like ethanol (Steinbusch, Hamelers, Schaap, Kampman, & Buisman, 2010). Likewise, efforts in the electro-fermentation space have been searching for other methods of electrosynthesis that extend beyond the conventional MEC design. Several recent reviews illustrate the potential of BES to electrosynthesize biofuels and VFAs from CO₂, electroferment biofuels from substrates like glycerol, and to integrate with biorefineries to produce biofuels from industrial waste (Brown, Harnisch, Dockhorn, & Schröder, 2015; R Moscoviz, Toledo-Alarcón, & Trably, 2016;

Sadhukhan, Lloyd, Scott, & Premier, 2016). Many of these studies use BES reactors with either electro-active anodes, cathodes or both, to produce valuable products from waste.

Lastly, to fully realize the potential for the ADMEC platform, the system will have to be scaled up. The two main methods to do this are: 1. scale-up the size of a single system or 2. integrate several smaller systems in parallel. Reviews on BES materials for scale-up, pilot-scale studies and other techno-economic factors have been published previously (a. Escapa et al., 2015; Janicek et al., 2014; Logan, 2010). Tubular BES designs are the most common for scale-up because they can closely replicate plug-flow conditions and exhibit minimal dead space along the reactor (JR Kim et al., 2011). Tubular reactors are also relatively easy to scale in a series configuration. Maintaining lab-scale performance after scaling up BES has been a notable issue in every study to date (Beegle & Borole, n.d.; a. Escapa et al., 2015; Janicek et al., 2014). One of the greatest obstacles is to maintain a high current density throughout the anode chamber. Scaling-up the anode in 3-dimensions can limit mass and charge transfer, which will reduce the volumetric efficiency. Gil-Carrera et al showed that thick anodes can limit the growth of electroactive bacteria and reduce current densities. The proposed solution is an electrode with very high surface area and limited thickness (5-10 mm) to optimize current output (Gil-Carrera et al., 2011). When using several small reactors in series and parallel to replicate the output of a large reactor, there are other obstacles present. Power management between biological reactors in series and/or parallel is becoming more pressing as the costs of building large-scale systems are still too high. Several publications by Ieropoulos at the University of Bristol have investigated the role of power management in scale up (Ieropoulos, Greenman, & Melhuish, 2008; Walter, Greenman, & Ieropoulos, 2014).

A combination of scale-up strategies, new reactor designs using MBR's and/or tubular reactors, alternative pretreatment methods, and operational conditions will be used to further evaluate the ADMEC platform for wastewater treatment.

Conclusions

This study evaluated the combination of wastewater pretreatment and an ADMEC treatment system to recover hydrogen gas and biogas from domestic wastewater. The configuration used in the study was chosen to optimize the conversion of organic material to hydrogen gas in an MEC. Two pretreatment methods, alkaline and thermal hydrolysis, were selected due to low cost and ease of application to increase the soluble fraction of COD and accelerate the biological conversion process to hydrogen, with anaerobic digestion as an intermediate stage. In each case, pretreatment increased the soluble COD content, by 25% and 20% for alkaline and thermal pretreatment, respectively, compared to the control but had varying effects on anaerobic digestion performance. The methane content in AD biogas was higher in pretreated groups, $78.29 \pm 2.89\%$ and $73.2 \pm 1.79\%$, for alkaline and thermal, than the control, $50.26 \pm 0.53\%$, but the overall biogas production rates were lower than the control, 20 and 30 mL CH₄/gCOD*d for alkaline and thermal compared to 80 mL CH₄/gCOD*d. The effluent stream from the thermally pretreated digesters was the best substrate for microbial electrolysis, in terms of hydrogen production and energy efficiency. These MECs produced 1.7 ± 0.2 L-H₂/L*d, 0.3 ± 0.1 L-H₂/L*d, and 0.29 ± 0.1 L-H₂/L*d, for thermal, alkaline, and control reactors, which was low compared to the acetate and propionate controls, which yielded 5.79 ± 0.03 L-H₂/L*d and 3.49 ± 0.10 L-H₂/L*d, respectively. The PT effluent streams were not ideal substrates for microbial electrolysis. As mentioned above, the composition of these substrates was not

comprised of organic acids and thus were not suitable substrates for the reactors in this study, which were enriched with acetic acid, propionic acid, and glucose.

A COD balance comparing the control, alkaline and thermal hydrolysis treatment processes showed that the flux of electrons to MEC's was increased when pretreatment was applied. The COD balance also identified potential electron sinks that can be addressed in future studies, like biogas production and biomass accumulation in the anaerobic digester. These sinks comprised over 20% of the total COD sinks in each configuration. Integrating a combination of the scale-up strategies, new reactor designs with MBR's and/or tubular reactors, alternative pretreatment methods, and operational conditions mentioned in the discussion, the flux of COD may be modified to energy sinks, like electrons released during oxidation. The energy production analysis reflected many of the results from the COD balance. The control configuration produced the most energy from AD, $2,397 \pm 0.0$ J/gCOD, compared to 468 ± 0.0 J/gCOD and 830 ± 0.0 J/gCOD for alkaline and thermal, respectively. The pretreatment substrates, although not ideal, were better substrates than the control for microbial electrolysis and yielded 68 ± 14 J/gCOD, 246 ± 23 J/gCOD, and 214 ± 46 J/gCOD for the control, alkaline, and thermal groups. Conversely, the addition of thermally pretreated AD effluent into the MECs produced significant increases in hydrogen production. MECs fed with control and alkaline digester effluent produced 234 ± 53 J/gCOD and 313 ± 140 J/gCOD, compared with $1,422 \pm 82$ J/gCOD in the thermal digester effluent group.

Overall, the addition of a pretreatment stage did not have significant positive impacts on overall energy recovery. The energy recovered from the microbial electrolysis of thermally pretreated AD sludge was improved compared to the control, but this was outdone by the inhibited biogas production from AD. Thermal hydrolysis as a pretreatment stage improved energy recovery from the ADMEC, in the form of hydrogen, and inhibited biogas production. The net impact of thermal pretreatment was nearly identical to the control, with a 9% loss in energy produced. The overall energy production from ADMEC with thermal pretreatment was $2,466 \pm 36$ J/gCOD, compared to $2,699 \pm 38$ J/gSCOD and $1,028 \pm 162$ J/gSCOD, for the control and alkaline groups. Alkaline pretreatment had a net negative effect on energy production in this configuration. The effluent concentrations from this study were above EPA levels for secondary water treatment. Future research on this platform will focus on improve COD removal. Based on the results from this study, the primary suggestion for the investigation of the ADMEC platform is to refrain from separating a wastewater substrate after pretreatment. This substrate separation negatively impacts AD performance and the pretreatment effluent by itself is a poor substrate for microbial electrolysis. Removing the separation stage and modifying the operational conditions of the digester to create a robust fermenter stage would improve the digester effluent quality as an MEC substrate, leading to improved hydrogen gas production, based on the results presented in this study.

Acknowledgements:

This work was supported by funding from Oak Ridge National Laboratory. The work was co-authored by UT-Batelle, LLC, and was conducted under a contract No. *DE-AC05-00OR22725* with the U.S. Department of Energy. JRB was partially supported by the Bredesen Center for Interdisciplinary Research and Education.

Personal Perspective

Working on this research was very exciting for me, considering my interests in entrepreneurship and technology commercialization. In this section, I will briefly discuss the current and projected future market conditions for AD and BES technologies, as well as some potential technological and financing strategies to improve the economics of the proposed treatment systems. As mentioned in the above chapters, development of full-scale BES is a barrier to the commercialization of this technology. According to a recent market report by Research and Markets, there are only seven prominent companies working in this space: Cambrian Innovation Inc., Microbial Robotics, Microrganic Technologies Inc., Triqua International Bv, Eletrochem, Emefcy, and Prongineer (Research and Markets, 2016). A similar report by Micromarket Monitor, focused on MFC's only, found that the same seven companies are all focused on R&D and the first companies to bring the technology to market will become market leaders (Micromarket Monitor, 2016). Collectively, this suggests that the bioelectrochemical systems market is very new, has few barriers to entry, and is highly fragmented due to the lack of a clear industry leader. The immaturity of this market is further emphasized by the market size. The Micromarket Monitor report estimates that the 2017 global MFC market size is \$9.0 mm and is expected to grow at a CAGR of 9.5% annually to 2025, reaching an estimated market size of \$18.6 mm.

By contrast, the market for anaerobic digestion technology is much larger and the technology is often considered to be mature. A market report by SBI Energy estimated that the 2006 market size for waste-to-energy AD was \$1.47 bn. (SBI Energy, 2012b). This report explicitly excluded AD treating municipal wastewater. This market is expected to grow to \$4.74 bn by 2021, growing at a CAGR of 10.3%. Most of this growth is expected to occur in Asia and North America. The European market for AD is currently dominated by Germany, which is showing signs of saturation, but is expected to see growth in the UK and Italy. The recent development and commercialization of membrane bioreactors (MBRs) may lead to new growth in AD markets, specifically in wastewater treatment. There are several large, established companies in the water treatment industry that have demonstrated commercial success with MBRs: such as GE, Kubota, Ovivo, Pentair, Xylem, and Veolia (SBI Energy, 2012a). MBRs can be used with either microfilters (10-0.1 μm) or ultrafilters (0.1-0.01 μm). The estimated 2007 global market size for the microfiltration and ultrafiltration markets were \$187 mm and \$183 mm, respectively. These markets are expected to grow in 2021 to \$1.14 bn and \$1.35 bn, respectively, growing at a 2012-2021 CAGR of 14% and 16%, respectively (SBI Energy, 2012a). The major barriers for MBR technologies, discussed elsewhere in this thesis, are membrane fouling, maintenance costs, and membrane costs.

I think there is great potential for BES and MBR technologies to be integrated together for wastewater treatment. I think MBRs can overcome many of the obstacles that AD has, such as large footprint, high solids requirements, and long retention times. Conversations I have conducted with wastewater treatment operators revealed that some WRRFs are very interested in purchasing MBRs because of the high-quality effluent that is produced, but the life-cycle maintenance costs for membranes is a major obstacle. The capacity to generate renewable energy and/or disinfection products like hydrogen peroxide from BES can reduce the operational costs for a water treatment train and potentially open opportunities to fund MBRs with a net-positive or net-neutral impact on overall finances.

There are several relevant research areas that are essential for the commercialization of MBRs and BES. Some of them are straightforward and have been addressed in this thesis, such as alternative membrane materials to reduce costs, reducing overpotentials to improve efficiency, optimizing operational conditions, etc. Beyond these areas, I think that synthetic biology, synthetic ecology, and metabolic engineering present some exciting fields for large breakthroughs in bioelectrochemistry. Genetic engineering has recently demonstrated improvements in nanowire conductivity by 5,000 to 1 million times in engineered *G. sulfurreducens* compared to wild-type *G. sulfurreducens* and wild-type *G. uraniireducens* (Tan et al., 2017). Beyond this, research into engineering microbial communities that demonstrate long-term, stable current production in BES and long-term fitness and stability in MBRs and/or AD will, I believe, improve the viability of these technologies for energy and value-added product generation (Stenuit & Agathos, 2015; Zomorodi & Segre, 2016).

The status of the wastewater infrastructure in the US provides another opportunity for innovation. According to recent ASCE reports, the current wastewater infrastructure received a D+ on the 2017 report card (ASCE Foundation, 2017). Not only is the existing infrastructure aging and reaching its upper limit on useful lifetime but the growing and shifting US population is changing the demand for water treatment. By 2032, an expected 56 million more US citizens will connect to centralized treatment systems, requiring an estimated 532 new treatment systems to come online (ASCE Foundation, 2017). Three strategies to tackle this challenge are: 1. Resource and energy recovery from wastewater, 2. Public-Private partnerships (PPP), and 3. Decentralization (ASCE Foundation, 2017; Daigger, 2009; Guest et al., 2009; World Bank Group, 2017). The first strategy has been addressed throughout this thesis report and will not be discussed here further. There is a great opportunity for private companies to work with water treatment facilities to improve the sustainability and infrastructure in the US. Federal funding for water infrastructure, the Clean Water State Revolving Fund (CWSRF), has been insufficient in recent decades, providing on average \$1.4 bn per year when nearly \$8 bn is required to maintain and improve water infrastructure. ASCE proposed that stimulating CWSRF appropriations under the Clean Water Act (CWA) and eliminating the state cap on private investment could help reduce underfunding for water infrastructure, closing the gap on the estimated \$271 billion needed by 2032 to improve infrastructure (ASCE Foundation, 2017). Private companies can innovate in other ways as well. Companies like Cambrian Innovation have developed alternative financing tools, like the Water-Energy Purchase Agreement (WEPA), to offer decentralized water treatment as a service without customers paying expensive capital costs (Cambrian Innovation, 2017). These kinds of non-technical innovations are exceedingly important and represent one area where private companies thrive over government organizations.

There are also other industries that provide enticing business models that the wastewater industry can adopt to improve the long-term financial and environmental sustainability of water treatment. This transition has already begun with small changes, such as the change in verbiage from Wastewater Treatment Plant (WWTP) to Water Resource Recovery Facility (WRRF), as implemented by the Water Environment Federation (WEF) in 2013. This reflects the change in thinking to view wastewater, and other wastes, as a resource and not a burden. This perspective been adopted by the Office of Energy Efficiency & Renewable Energy (EERE) in the US Department of Energy's initiative on integrated biorefineries (Department of Energy, 2014). The core focus of integrated biorefineries (IBR) is to use all of the components of renewable biomass sources, like grasses, agricultural residues, and woody substrates, and convert them into high value products, such as liquid fuels, polymers, composites, and pharmaceuticals (Sadhukhan et

al., 2016). BES has already been used in IBR processes to recover hydrogen from the rich bio-oils produced as a byproduct of pyrolysis (A. J. Lewis et al., 2015; Alex J. Lewis & Borole, 2016). The ability to produce a wide range of products from waste, without in turn generating new forms of waste, is integral to the creation of circular economies. NGO's and other organizations, like the Ellen MacArthur Foundation, are actively working to create initiatives for circular economies.

To succeed in these research and commercialization endeavors, the field of bioelectrochemistry will need to continue expanding as an interdisciplinary field of study, extending to include more robust assessments to address environmental, economical, and social impacts to influence decision making. In addition, it is my view that graduate students should be aware of and pursue careers in entrepreneurship. Studies conducted in the US and EU report that companies in the biotechnology and pharmaceuticals industries outsource large portions of their R&D to research institutions and/or rely on research partnerships with new companies to develop new products, due to the high costs of supporting internal R&D (European Association of Research and Technology Organizations, 2001; Life Science Strategy Group, 2014). Students that push the limits of innovation in the lab can amplify the impact of their research by commercializing technology and bringing it to the real world.

Disclaimer: The views expressed in this section do not necessarily reflect the views and opinions of Oak Ridge National Laboratory, the University of Tennessee, Drs. Borole, Hazen, and Zinser, or Grow Bioplastics.

References

- Acharya, B., Dutta, A., & Minaret, J. (2015). Review on comparative study of dry and wet torrefaction. *Sustainable Energy Technologies and Assessments*, 12, 26–37. <http://doi.org/10.1016/j.seta.2015.08.003>
- Administration, U. E. I. (2016). Electricity Data.
- Aghaei, J., & Alizadeh, M. I. (2013). Demand response in smart electricity grids equipped with renewable energy sources: A review. *Renewable and Sustainable Energy Reviews*. <http://doi.org/10.1016/j.rser.2012.09.019>
- Agustina, T. E., Ang, H. M., & Vareek, V. K. (2005). A review of synergistic effect of photocatalysis and ozonation on wastewater treatment. *Journal of Photochemistry and Photobiology C: Photochemistry Reviews*, 6(4), 264–273. <http://doi.org/10.1016/j.jphotochemrev.2005.12.003>
- Allen, M., Barros, V., Broome, J., & Cramer, W. (2014). IPCC Climate Change AR5 Synthesis Report, (November), 116.
- An, J., Kim, B., Jang, J. K., Lee, H. S., & Chang, I. S. (2014). New architecture for modulization of membraneless and single-chambered microbial fuel cell using a bipolar plate-electrode assembly (BEA). *Biosensors and Bioelectronics*, 59, 28–34. <http://doi.org/10.1016/j.bios.2014.02.063>
- APHA/AWWA/WEF. (2012). *Standard Methods for the Examination of Water and Wastewater. Standard Methods*. <http://doi.org/ISBN 9780875532356>
- Appels, L., Baeyens, J., Degrève, J., & Dewil, R. (2008). Principles and potential of the anaerobic digestion of waste-activated sludge. *Progress in Energy and Combustion Science*, 34(6), 755–781. <http://doi.org/10.1016/j.pecs.2008.06.002>
- Appels, L., Lauwers, J., Degrve, J., Helsen, L., Lievens, B., Willems, K., ... Dewil, R. (2011). Anaerobic digestion in global bio-energy production: Potential and research challenges. *Renewable and Sustainable Energy Reviews*, 15(9), 4295–4301. <http://doi.org/10.1016/j.rser.2011.07.121>
- Arena, U. (2012). Process and technological aspects of municipal solid waste gasification. A review. *Waste Management*, 32(4), 625–639. <http://doi.org/10.1016/j.wasman.2011.09.025>
- Ariunbaatar, J., Panico, A., Esposito, G., Pirozzi, F., & Lens, P. N. L. (2014). Pretreatment methods to enhance anaerobic digestion of organic solid waste. *Applied Energy*, 123, 143–156. <http://doi.org/10.1016/j.apenergy.2014.02.035>
- ASCE Foundation. (2017). *2017 Wastewater Infrastructure Report Card*.
- Association Energy Information. (2012). *Primary Energy Consumption by Source and Sector , 2014* (Vol. 2012).
- Atlas, R. M., & Hazen, T. C. (2011). Oil biodegradation and bioremediation: A tale of the two worst spills in U.S. history. *Environmental Science and Technology*, 45(16), 6709–6715. <http://doi.org/10.1021/es2013227>
- Bainotti, A. E., & Nishio, N. (2000). Growth kinetics of *Acetobacterium* sp. on methanol-formate in continuous culture. *Journal of Applied Microbiology*, 88(2), 191–201. <http://doi.org/10.1046/j.1365-2672.2000.00854.x>
- Banks, C. J., Chesshire, M., Heaven, S., & Arnold, R. (2011). Anaerobic digestion of source-segregated domestic food waste: Performance assessment by mass and energy balance. *Bioresource Technology*, 102(2), 612–620. <http://doi.org/10.1016/j.biortech.2010.08.005>
- Batstone, D. J., & Viridis, B. (2014). The role of anaerobic digestion in the emerging energy economy. *Current Opinion in Biotechnology*, 27, 142–149. <http://doi.org/10.1016/j.copbio.2014.01.013>

- Beegle, J., & Borole, A. P. (n.d.). Energy Production from Waste: Evaluation of Anaerobic Digestion and Bioelectrochemical Systems based on Energy Efficiency, Economic, and Environmental Factors. *Environmental Progress & Sustainable Energy*.
- Bo, T., Zhu, X., Zhang, L., Tao, Y., He, X., & Li, D. (2014). A new upgraded biogas production process: coupling microbial electrolysis cell and anaerobic digestion in single-chamber, barrel-shape stainless steel reactor. *Electrochemistry*. Retrieved from <http://www.sciencedirect.com/science/article/pii/S1388248114001581>
- Bolzonella, D., Pavan, P., Battistoni, P., & Cecchi, F. (2005). Mesophilic anaerobic digestion of waste activated sludge: Influence of the solid retention time in the wastewater treatment process. *Process Biochemistry*, *40*(3–4), 1453–1460. <http://doi.org/10.1016/j.procbio.2004.06.036>
- Bond, D. R., & Lovley, D. R. (2003). Electricity Production by *Geobacter sulfurreducens* Attached to Electrodes Electricity. *Applied and Environmental Microbiology*, *69*(3), 1548–1555. <http://doi.org/10.1128/AEM.69.3.1548>
- Bordeleau, É. L., & Droste, R. L. (2011). Comprehensive review and compilation of pretreatments for mesophilic and thermophilic anaerobic digestion. *Water Science and Technology*, *63*(2), 291–296. <http://doi.org/10.2166/wst.2011.052>
- Borole, A. P., Hamilton, C. Y., & Vishnivetskaya, T. A. (2011). Enhancement in current density and energy conversion efficiency of 3-dimensional MFC anodes using pre-enriched consortium and continuous supply of electron donors. *Bioresource Technology*, *102*(8), 5098–5104. <http://doi.org/10.1016/j.biortech.2011.01.045>
- Borole, A. P., Hamilton, C. Y., Vishnivetskaya, T. A., Leak, D., Andras, C., Morrell-Falvey, J., ... Davison, B. (2009). Integrating engineering design improvements with exoelectrogen enrichment process to increase power output from microbial fuel cells. *Journal of Power Sources*, *191*(2), 520–527. <http://doi.org/10.1016/j.jpowsour.2009.02.006>
- Borole, A. P., Hamilton, C. Y., Vishnivetskaya, T., Leak, D., & Andras, C. (2009). Improving power production in acetate-fed microbial fuel cells via enrichment of exoelectrogenic organisms in flow-through systems. *Biochemical Engineering Journal*, *48*(1), 71–80. <http://doi.org/10.1016/j.bej.2009.08.008>
- Borole, A. P., & Mielenz, J. R. (2011). Estimating hydrogen production potential in biorefineries using microbial electrolysis cell technology. *International Journal of Hydrogen Energy*, *36*, 14787–14795. <http://doi.org/10.1016/j.ijhydene.2011.03.152>
- Borole, A. P., Reguera, G., Ringeisen, B., Wang, Z.-W., Feng, Y., & Kim, B. H. (2011). Electroactive biofilms: Current status and future research needs. *Energy & Environmental Science*, *4*(12), 4813. <http://doi.org/10.1039/c1ee02511b>
- Bouallagui, H., Lahdheb, H., & Romdan, E. (2009). Improvement of fruit and vegetable waste anaerobic digestion performance and stability with co-substrates addition. *Journal of Environmental Management*. Retrieved from <http://www.sciencedirect.com/science/article/pii/S0301479708003605>
- Bougrier, C., Albasi, C., Delgenès, J. P., & Carrère, H. (2006). Effect of ultrasonic, thermal and ozone pre-treatments on waste activated sludge solubilisation and anaerobic biodegradability. *Chemical Engineering and Processing: Process Intensification*, *45*(8), 711–718. <http://doi.org/10.1016/j.cep.2006.02.005>
- Brown, R. K., Harnisch, F., Dockhorn, T., & Schröder, U. (2015). Examining sludge production in bioelectrochemical systems treating domestic wastewater. *Bioresource Technology*, (SEPTEMBER). <http://doi.org/10.1016/j.biortech.2015.09.081>

- Buzby, J. C., Wells, H. F., & Hyman, J. (2014). The Estimated Amount, Value, and Calories of Postharvest Food Losses at the Retail and Consumer Levels in the United States. *Economic Information Bulletin*, (EIB-121), 39.
- Call, D., & Logan, B. E. (2008). Hydrogen production in a single chamber microbial electrolysis cell lacking a membrane. *Environmental Science and Technology*, 42(9), 3401–3406. <http://doi.org/10.1021/es8001822>
- Cambrian Innovation. (2017). Water-Energy Purchasing Agreement (WEPA). Retrieved from <http://cambrianinnovation.com/water-solutions/wepa/>
- Cao, Y., & Pawłowski, A. (2012). Sewage sludge-to-energy approaches based on anaerobic digestion and pyrolysis: Brief overview and energy efficiency assessment. *Renewable and Sustainable Energy Reviews*, 16(3), 1657–1665. <http://doi.org/10.1016/j.rser.2011.12.014>
- Carrère, H., Dumas, C., Battimelli, A., Batstone, D. J., Delgenès, J. P., Steyer, J. P., & Ferrer, I. (2010). Pretreatment methods to improve sludge anaerobic degradability: a review. *Journal of Hazardous Materials*, 183(1–3), 1–15. <http://doi.org/10.1016/j.jhazmat.2010.06.129>
- Cavalieri, D., McGovern, P. E., Hartl, D. L., Mortimer, R., & Polsinelli, M. (2003). Evidence for *S. cerevisiae* Fermentation in Ancient Wine. In *Journal of Molecular Evolution* (Vol. 57). <http://doi.org/10.1007/s00239-003-0031-2>
- Cavinato, C., Fatone, F., Bolzonella, D., & Pavan, P. (2010). Thermophilic anaerobic co-digestion of cattle manure with agro-wastes and energy crops: Comparison of pilot and full scale experiences. *Bioresource Technology*, 101(2), 545–550. <http://doi.org/10.1016/j.biortech.2009.08.043>
- Chen, X., Romano, R. T., & Zhang, R. (2010). Anaerobic digestion of food wastes for biogas production. *International Journal of Agricultural and Biological Engineering*, 3, 61–72. <http://doi.org/10.3965/j.issn.1934-6344.2010.04.061-072>
- Chen, Y., Cheng, J. J., & Creamer, K. S. (2008). Inhibition of anaerobic digestion process: A review. *Bioresource Technology*. <http://doi.org/10.1016/j.biortech.2007.01.057>
- Cheng, H., Scott, K., & Ramshaw, C. (2002). Intensification of Water Electrolysis in a Centrifugal Field. *Journal of The Electrochemical Society*, 149(11), D172. <http://doi.org/10.1149/1.1512916>
- Cheng, S., & Hamelers, H. V. M. (2008). Critical Review Microbial Electrolysis Cells for High Yield Hydrogen Gas Production from Organic Matter. *Environmental Science & Technology*, 42(23), 8630–8640. <http://doi.org/10.1021/es801553z>
- Cho, S. K., Im, W. T., Kim, D. H., Kim, M. H., Shin, H. S., & Oh, S. E. (2013). Dry anaerobic digestion of food waste under mesophilic conditions: Performance and methanogenic community analysis. *Bioresource Technology*, 131(2013), 210–217. <http://doi.org/10.1016/j.biortech.2012.12.100>
- Clauwaert, P., Mulenga, S., Aelterman, P., & Verstraete, W. (2009). Litre-scale microbial fuel cells operated in a complete loop. *Applied Microbiology and Biotechnology*, 83(2), 241–247. <http://doi.org/10.1007/s00253-009-1876-0>
- Daigger, G. T. (2009). Evolving Urban Water and Residuals Management Paradigms: Water Reclamation and Reuse, Decentralization, and Resource Recovery. *Water Environment Research*, 81(8), 809–823. <http://doi.org/10.2175/106143009X425898>
- De Vrieze, J., Gildemyn, S., Arends, J. B. a, Vanwonterghem, I., Verbeke, K., Boon, N., ... Rabaey, K. (2014). Biomass retention on electrodes rather than electrical current enhances stability in anaerobic digestion. *Water Research*, 54, 211–221. <http://doi.org/10.1016/j.watres.2014.01.044>

- Dekker, A., Ter Heijne, A., Saakes, M., Hamelers, H. V. M., & Buisman, C. J. N. (2009). Analysis and improvement of a scaled-up and stacked microbial fuel cell. *Environmental Science and Technology*, 43(23), 9038–9042. <http://doi.org/10.1021/es901939r>
- Demain, A. L. (2000). Small bugs , big business : The economic power of the microbe. *Biotechnology Advances*, 18, 499–514.
- Department of Energy. (2014). *Integrated Biorefineries: Reducing Investment Risk in Novel Technology*. U.S. Department of Energy. Retrieved from www.biofuels.energy.gov
- Ditzig, J., Liu, H., & Logan, B. E. (2007). Production of hydrogen from domestic wastewater using a bioelectrochemically assisted microbial reactor (BEAMR). *International Journal of Hydrogen Energy*, 32(13), 2296–2304. <http://doi.org/10.1016/j.ijhydene.2007.02.035>
- Dolfing, J. (2014). Syntrophy in microbial fuel cells. *The ISME Journal*, 8(10), 4–5. <http://doi.org/10.1038/ismej.2013.198>
- EIA. (2013). *Carbon Dioxide Emissions Coefficients*.
- El-Naggar, M. Y., Wanger, G., Leung, K. M., Yuzvinsky, T. D., Southam, G., Yang, J., ... Gorby, Y. a. (2010). Electrical transport along bacterial nanowires from *Shewanella oneidensis* MR-1. *Proceedings of the National Academy of Sciences of the United States of America*, 107(42), 18127–18131. <http://doi.org/10.1073/pnas.1004880107>
- Energy, U. D. of. (2013). FCTO Accomplishments and Progress.
- Escapa, A., Gómez, X., Tartakovsky, B., & Morán, A. (2012). Estimating microbial electrolysis cell (MEC) investment costs in wastewater treatment plants: Case study. *International Journal of Hydrogen Energy*, 37(24), 18641–18653. <http://doi.org/10.1016/j.ijhydene.2012.09.157>
- Escapa, A., Manuel, M. F., Morán, A., Gómez, X., Guiot, S. R., & Tartakovsky, B. (2009). Hydrogen production from glycerol in a membraneless microbial electrolysis cell. *Energy and Fuels*, 23(9), 4612–4618. <http://doi.org/10.1021/ef900357y>
- Escapa, A., Martin, M. S., & Moran, A. (2014). Potential Use of Microbial Electrolysis Cells in Domestic Wastewater Treatment Plants for Energy Recovery. *Fuel Cells*, 2(June), 1–10. <http://doi.org/10.3389/fenrg.2014.00019>
- Escapa, A., Mateos, R., Martínez, E. J., & Blanes, J. (2016). Microbial electrolysis cells: An emerging technology for wastewater treatment and energy recovery. From laboratory to pilot plant and beyond. *Renewable and Sustainable Energy Reviews*, 55, 942–956. <http://doi.org/10.1016/j.rser.2015.11.029>
- Escapa, a., San-Martín, M. I., Mateos, R., & Morán, a. (2015). Scaling-up of membraneless microbial electrolysis cells (MECs) for domestic wastewater treatment: Bottlenecks and limitations. *Bioresource Technology*, 180, 72–78. <http://doi.org/10.1016/j.biortech.2014.12.096>
- Esteve-Núñez, A., Rothermich, M., Sharma, M., & Lovley, D. (2005). Growth of *Geobacter sulfurreducens* under nutrient-limiting conditions in continuous culture. *Environmental Microbiology*, 7(5), 641–648. <http://doi.org/10.1111/j.1462-2920.2005.00731.x>
- Eurelectric. (2003). Efficiency in Electricity Generation, (July), 30.
- European Association of Research and Technology Organizations. (2001). *The Trend in Industry towards R&D Outsourcing*.
- Fdz-Polanco, F., & Velazquez, R. (2008). Continuous thermal hydrolysis and energy integration in sludge anaerobic digestion plants. *Water Science and*. Retrieved from <http://wst.iwaponline.com/content/57/8/1221.abstract>
- Foley, J. M., Rozendal, R. a, Hertle, C. K., Lant, P. a, & Rabaey, K. (2010). Life cycle

- assessment of high-rate anaerobic treatment, microbial fuel cells, and microbial electrolysis cells. *Environmental Science & Technology*, 44(xx), 3629–3637.
<http://doi.org/10.1021/es100125h>
- Freguia, S., Rabaey, K., Yuan, Z., & Keller, J. (2008). Syntrophic processes drive the conversion of glucose in microbial fuel cell anodes. *Environmental Science and Technology*, 42(21), 7937–7943. <http://doi.org/10.1021/es800482e>
- Fytili, D., & Zabaniotou, A. (2008). Utilization of sewage sludge in EU application of old and new methods—A review. *Renewable and Sustainable Energy Reviews*, 12(1), 116–140.
<http://doi.org/10.1016/j.rser.2006.05.014>
- Gao, H., Scherson, Y. D., & Wells, G. F. (2014). Towards energy neutral wastewater treatment: methodology and state of the art. *Environmental Science: Processes & Impacts*, 16(6), 1223. <http://doi.org/10.1039/c4em00069b>
- Gil-Carrera, L., Escapa, A., Carracedo, B., Moran, A., & Gomez, X. (2013). Performance of a semi-pilot tubular microbial electrolysis cell (MEC) under several hydraulic retention times and applied voltages. *Bioresource Technology*, 146, 63–69.
<http://doi.org/10.1016/j.biortech.2013.07.020>
- Gil-Carrera, L., Escapa, A., Moreno, R., & Moran, A. (2013). Reduced energy consumption during low strength domestic wastewater treatment in a semi-pilot tubular microbial electrolysis cell. *Journal of Environmental Management*, 122, 1–7.
<http://doi.org/10.1016/j.jenvman.2013.03.001>
- Gil-Carrera, L., Mehta, P., Escapa, A., Morán, A., García, V., Guiot, S. R., & Tartakovsky, B. (2011). Optimizing the electrode size and arrangement in a microbial electrolysis cell. *Bioresource Technology*, 102(20), 9593–9598.
<http://doi.org/10.1016/j.biortech.2011.08.026>
- Goldstein, R., & Smith, W. (2002). Water & Sustainability (Volume 4): U.S. Electricity Consumption for Water Supply & Treatment - The Next Half Century. *Water Supply*, 4(Volume 4), 93.
- Gómez, X., Cuetos, M. J., Cara, J., Morán, A., & García, A. I. (2006). Anaerobic co-digestion of primary sludge and the fruit and vegetable fraction of the municipal solid wastes. *Renewable Energy*, 31(12), 2017–2024. <http://doi.org/10.1016/j.renene.2005.09.029>
- Gorby, Y. A., Yanina, S., McLean, J. S., Rosso, K. M., Moyles, D., Dohnalkova, A., ... Fredrickson, J. K. (2006). Electrically conductive bacterial nanowires produced by *Shewanella oneidensis* strain MR-1 and other microorganisms. *Proceedings of the National Academy of Sciences of the United States of America*, 103(30), 11358–63.
<http://doi.org/10.1073/pnas.0604517103>
- Gregory, K. B., & Lovley, D. R. (2005). Remediation and recovery of uranium from contaminated subsurface environments with electrodes. *Environmental Science & Technology*, 39(22), 8943–7. <http://doi.org/10.1021/es050457e>
- Guest, J., Skerlos, S., Barnard, J., Beck, M., Daigger, G., Hilger, H., ... Love, N. G. (2009). A New Planning and Design Paradigm to Achieve Sustainable Resource Recovery from Wastewater. *Environmental Science and Technology*, 43(16), 6121–6125.
<http://doi.org/10.1021/es803001r>
- Gunaseelan, V. N. (1997). Anaerobic digestion of biomass for methane production: A review. *Biomass and Bioenergy*. [http://doi.org/10.1016/S0961-9534\(97\)00020-2](http://doi.org/10.1016/S0961-9534(97)00020-2)
- Haandel, A., & Lubbe, J. (2007). *Handbook of biological wastewater treatment: Design and optimisation of activated sludge systems. Handbook of biological wastewater treatment:*

- Retrieved from
<http://scholar.google.com/scholar?hl=en&btnG=Search&q=intitle:Handbook+Biological+Waste+Water+Treatment#9>
<http://www.cabdirect.org/abstracts/20113241613.html>
- Hari, A. R., Katuri, K. P., Gorrion, E., Logan, B. E., & Saikaly, P. E. (2016a). Multiple paths of electron flow to current in microbial electrolysis cells fed with low and high concentrations of propionate. *Applied Microbiology and Biotechnology*, 1–13.
<http://doi.org/10.1007/s00253-016-7402-2>
- Hari, A. R., Katuri, K. P., Gorrion, E., Logan, B. E., & Saikaly, P. E. (2016b). Multiple paths of electron flow to current in microbial electrolysis cells fed with low and high concentrations of propionate. *Applied Microbiology and Biotechnology*, (May).
<http://doi.org/10.1007/s00253-016-7402-2>
- Harnisch, F., Rosa, L. F. M., Kracke, F., Viridis, B., & Krömer, J. O. (2015). Electrifying White Biotechnology: Engineering and Economic Potential of Electricity-Driven Bio-Production. *ChemSusChem*, 8(5), 758–766. <http://doi.org/10.1002/cssc.201402736>
- Hays, S., Zhang, F., & Logan, B. E. (2011). Performance of two different types of anodes in membrane electrode assembly microbial fuel cells for power generation from domestic wastewater. *Journal of Power Sources*, 196(20), 8293–8300.
<http://doi.org/10.1016/j.jpowsour.2011.06.027>
- Heidrich, E. S., Curtis, T. P., & Dolfing, J. (2011). Determination of the internal chemical energy of wastewater. *Environmental Science and Technology*, 45(2), 827–832.
<http://doi.org/10.1021/es103058w>
- Heidrich, E. S., Dolfing, J., Scott, K., Edwards, S. R., Jones, C., & Curtis, T. P. (2013). Production of hydrogen from domestic wastewater in a pilot-scale microbial electrolysis cell. *Applied Microbiology and Biotechnology*, 97(15), 6979–6989.
<http://doi.org/10.1007/s00253-012-4456-7>
- Heidrich, E. S., Edwards, S. R., Dolfing, J., Cotterill, S. E., & Curtis, T. P. (2014). Performance of a pilot scale microbial electrolysis cell fed on domestic wastewater at ambient temperatures for a 12month period. *Bioresource Technology*, 173, 87–95.
<http://doi.org/10.1016/j.biortech.2014.09.083>
- Hussey, K., & Pittock, J. (2012). The energy-water nexus: Managing the links between energy and water for a sustainable future. *Ecology and Society*, 17(1). <http://doi.org/10.5751/ES-04641-170131>
- Ieropoulos, I., Greenman, J., & Melhuish, C. (2008). Microbial fuel cells based on carbon veil electrodes: Stack configuration and scalability. *International Journal of Energy Research*, 32(13), 1228–1240. <http://doi.org/10.1002/er.1419>
- Janicek, A., Fan, Y., & Liu, H. (2014). Design of microbial fuel cells for practical application: a review and analysis of scale-up studies. *Biofuels*, 5(1), 79–92.
<http://doi.org/10.4155/bfs.13.69>
- Janicek, P., Bartacek, J., Kutil, J., Zabranska, J., & Dohanyos, M. (2012). Potentials and limits of anaerobic digestion of sewage sludge: Energy self-sufficient municipal wastewater treatment plant? *Water Science and Technology*, 66(6), 1277–1281.
<http://doi.org/10.2166/wst.2012.317>
- Joskow, P. L. (2011). Comparing the costs of intermittent and dispatchable electricity generating technologies. In *American Economic Review* (Vol. 101, pp. 238–241).
<http://doi.org/10.1257/aer.101.3.238>
- Katuri, K., & Werner, C. (2014). A novel anaerobic electrochemical membrane bioreactor

- (AnEMBR) with conductive hollow-fiber membrane for treatment of low-organic strength solutions. *Science & Technology*. Retrieved from <http://pubs.acs.org/doi/abs/10.1021/es504392n>
- Kepp, U., Machenbach, I., & Weisz, N. (2000). Enhanced stabilisation of sewage sludge through thermal hydrolysis-three years of experience with full scale plant. *Water Science and*. Retrieved from <http://wst.iwaponline.com/content/42/9/89.abstract>
- Kiely, P., Regan, J., & Logan, B. (2011). The electric picnic: synergistic requirements for exoelectrogenic microbial communities. *Current Opinion in Biotechnology*. Retrieved from <http://www.sciencedirect.com/science/article/pii/S0958166911000425>
- Kim, J., Park, C., Kim, T.-H., Lee, M., Kim, S., Kim, S.-W., & Lee, J. (2003). Effects of various pretreatments for enhanced anaerobic digestion with waste activated sludge. *Journal of Bioscience and Bioengineering*, 95, 271–275. <http://doi.org/10.1263/jbb.95.271>
- Kim, J., Rodríguez, J., & Hawkes, F. (2011). Increasing power recovery and organic removal efficiency using extended longitudinal tubular microbial fuel cell (MFC) reactors. *Energy &*. Retrieved from <http://pubs.rsc.org/is/content/articlehtml/2011/ee/c0ee00073f>
- Koch, C., Kuchenbuch, A., Kretzschmar, J., Wedwitschka, H., Liebetrau, J., Müller, S., & Harnisch, F. (2015). Coupling electric energy and biogas production in anaerobic digesters – impacts on the microbiome. *RSC Adv.*, 5(40), 31329–31340. <http://doi.org/10.1039/C5RA03496E>
- Kracke, F., Vassilev, I., & Krömer, J. O. (2015). Microbial electron transport and energy conservation – the foundation for optimizing bioelectrochemical systems. *Frontiers in Microbiology*, 6(MAY). <http://doi.org/10.3389/fmicb.2015.00575>
- Labatut, R. A., Angenent, L. T., & Scott, N. R. (2011). Biochemical methane potential and biodegradability of complex organic substrates. *Bioresource Technology*, 102(3), 2255–2264. <http://doi.org/10.1016/j.biortech.2010.10.035>
- Latif, M. a., Mehta, C. M., & Batstone, D. J. (2015). Low pH anaerobic digestion of waste activated sludge for enhanced phosphorous release. *Water Research*, 81, 288–293. <http://doi.org/10.1016/j.watres.2015.05.062>
- Lee, H., Torres, C., & Rittmann, B. (2009). Effects of substrate diffusion and anode potential on kinetic parameters for anode-respiring bacteria. *Environmental Science &*. Retrieved from <http://pubs.acs.org/doi/abs/10.1021/es9015519>
- Lewis, A. J., & Borole, A. P. (2016). Understanding the impact of flow rate and recycle on the conversion of a complex biorefinery stream using a flow-through microbial electrolysis cell. *Biochemical Engineering Journal*. <http://doi.org/10.1016/j.bej.2016.06.008>
- Lewis, A. J., Ren, S., Ye, X., Kim, P., Labbe, N., & Borole, A. P. (2015). Hydrogen production from switchgrass via an integrated pyrolysis-microbial electrolysis process. *Bioresource Technology*, 195, 231–241. <http://doi.org/10.1016/j.biortech.2015.06.085>
- Li, H., Jin, Y., Mahar, R., Wang, Z., & Nie, Y. (2008). Effects and model of alkaline waste activated sludge treatment. *Bioresource Technology*, 99(11), 5140–5144. <http://doi.org/10.1016/j.biortech.2007.09.019>
- Li, Z., Yao, L., Kong, L., & Liu, H. (2008). Electricity generation using a baffled microbial fuel cell convenient for stacking. *Bioresource Technology*, 99(6), 1650–1655. <http://doi.org/10.1016/j.biortech.2007.04.003>
- Life Science Strategy Group. (2014). *Top Trends in R&D Outsourcing Impacting Future R&D Success*.
- Liu, H., Cheng, S., Huang, L., & Logan, B. E. (2008). Scale-up of membrane-free single-

- chamber microbial fuel cells. *Journal of Power Sources*, 179(1), 274–279.
<http://doi.org/10.1016/j.jpowsour.2007.12.120>
- Liu, H., Grot, S., & Logan, B. E. (2005). Electrochemically assisted microbial production of hydrogen from acetate. *Environmental Science and Technology*, 39(11), 4317–4320.
<http://doi.org/10.1021/es050244p>
- Liu, H., Wang, J., Wang, A., & Chen, J. (2011). Chemical inhibitors of methanogenesis and putative applications. *Applied Microbiology and Biotechnology*, 89(5), 1333–1340.
<http://doi.org/10.1007/s00253-010-3066-5>
- Liu, J., Zhang, F., He, W., Yang, W., & Feng, Y. (2014). A microbial fluidized electrode electrolysis cell (MFEEC) for enhanced hydrogen production. *Journal of Power Sources*. Retrieved from <http://www.sciencedirect.com/science/article/pii/S037877531401297X>
- Liu, Y., & Whitman, W. B. (2008). Metabolic, phylogenetic, and ecological diversity of the methanogenic archaea. *Annals of the New York Academy of Sciences*, 1125, 171–189.
<http://doi.org/10.1196/annals.1419.019>
- Ljungdahl, L., Adams, M., Barton, L., Ferry, J., & Johnston, M. (2003). *Biochemistry and Physiology of Anaerobic Bacteria*.
- Logan, B. E. (2010). Scaling up microbial fuel cells and other bioelectrochemical systems. *Applied Microbiology and Biotechnology*, 85(6), 1665–1671.
<http://doi.org/10.1007/s00253-009-2378-9>
- Logan, B. E., Verstraete, W., & Rabaey, K. (2006). Microbial Fuel Cells : Methodology and Technology. *Environ. Science and Technology*, 40(17), 5181–5192.
- Lovley, D. R. (2006). Bug juice: harvesting electricity with microorganisms. *Nature Reviews Microbiology*, 4(7), 497–508. <http://doi.org/10.1038/nrmicro1442>
- Luque, R., Menéndez, J. A., Arenillas, A., & Cot, J. (2012). Microwave-assisted pyrolysis of biomass feedstocks: the way forward? *Energy & Environmental Science*, 5(2), 5481.
<http://doi.org/10.1039/c1ee02450g>
- Malkow, T. (2004). Novel and innovative pyrolysis and gasification technologies for energy efficient and environmentally sound MSW disposal. *Waste Management*, 24(1), 53–79.
[http://doi.org/10.1016/S0956-053X\(03\)00038-2](http://doi.org/10.1016/S0956-053X(03)00038-2)
- Malvankar, N. S., & Lovley, D. R. (2014). Microbial nanowires for bioenergy applications. *Current Opinion in Biotechnology*, 27C, 88–95. <http://doi.org/10.1016/j.copbio.2013.12.003>
- Marshall, C. W., Labelle, E. V., & May, H. D. (2013). Production of fuels and chemicals from waste by microbiomes. *Current Opinion in Biotechnology*, 24(3), 391–397.
<http://doi.org/10.1016/j.copbio.2013.03.016>
- Martín-González, L., Colturato, L. F., Font, X., & Vicent, T. (2010). Anaerobic co-digestion of the organic fraction of municipal solid waste with FOG waste from a sewage treatment plant: Recovering a wasted methane potential and enhancing the biogas yield. *Waste Management*, 30(10), 1854–1859. <http://doi.org/10.1016/j.wasman.2010.03.029>
- Mata-Alvarez, J., Macé, S., & Llabrés, P. (2000). Anaerobic digestion of organic solid wastes. An overview of research achievements and perspectives. *Bioresource Technology*, 74(1), 3–16. [http://doi.org/10.1016/S0960-8524\(00\)00023-7](http://doi.org/10.1016/S0960-8524(00)00023-7)
- McCarty, P. L., Bae, J., & Kim, J. (2011). Domestic wastewater treatment as a net energy producer-can this be achieved? *Environmental Science and Technology*, 45(17), 7100–7106.
<http://doi.org/10.1021/es2014264>
- McLean, J. S., Wanger, G., Gorby, Y. A., Wainstein, M., McQuaid, J., Ishii, S. ichi, ... Nealson, K. H. (2010). Quantification of Electron Transfer Rates to a Solid Phase Electron Acceptor

- through the Stages of Biofilm Formation from Single Cells to Multicellular Communities. *Environmental Science & Technology*, 44(7), 2721–2727. <http://doi.org/10.1021/es903043p>
- Merlino, G., Rizzi, A., Schievano, A., Tenca, A., Scaglia, B., Oberti, R., ... Daffonchio, D. (2013). Microbial community structure and dynamics in two-stage vs single-stage thermophilic anaerobic digestion of mixed swine slurry and market bio-waste. *Water Research*, 47(6), 1983–1995. <http://doi.org/10.1016/j.watres.2013.01.007>
- Miceli, J. F., Garcia-Pena, I., Parameswaran, P., Torres, C. I., & Krajmalnik-Brown, R. (2014). Combining microbial cultures for efficient production of electricity from butyrate in a microbial electrochemical cell. *Bioresource Technology*, 169, 169–174. <http://doi.org/10.1016/j.biortech.2014.06.090>
- Micromarket Monitor. (2016). *Microbial Fuel Cell Market*.
- Moriarty, K. (2013). *Feasibility Study of Anaerobic Digestion of Food Waste in St . Bernard , Louisiana A Study Prepared in Partnership with the Environmental Protection Agency for the RE-Powering America ' s Land Initiative : Siting Renewable Energy on Potentially Contaminat*.
- Moscoviz, R., Toledo-Alarcón, J., & Trably, E. (2016). Electro-fermentation: how to drive fermentation using electrochemical systems. *Trends in Biotechnology*. Retrieved from <http://www.sciencedirect.com/science/article/pii/S0167779916300282>
- Moscoviz, R., Toledo-Alarcón, J., Trably, E., & Bernet, N. (n.d.). Electro-Fermentation: How To Drive Fermentation Using Electrochemical Systems From Microbial Fuel Cells to EF. <http://doi.org/10.1016/j.tibtech.2016.04.009>
- Müller, V. (2003). Energy Conservation in Acetogenic Bacteria. *Applied and Environmental Microbiology*. <http://doi.org/10.1128/AEM.69.11.6345-6353.2003>
- Neyens, E., Baeyens, J., & Creemers, C. (2003). Alkaline thermal sludge hydrolysis. *Journal of Hazardous Materials*, 97(1–3), 295–314. [http://doi.org/10.1016/S0304-3894\(02\)00286-8](http://doi.org/10.1016/S0304-3894(02)00286-8)
- Oh, S. T., Kim, J. R., Premier, G. C., Lee, T. H., Kim, C., & Sloan, W. T. (2010). Sustainable wastewater treatment: how might microbial fuel cells contribute. *Biotechnology Advances*, 28(6), 871–881. <http://doi.org/10.1016/j.biotechadv.2010.07.008>
- Oller, I., Malato, S., & Sánchez-Pérez, J. a. (2011). Combination of Advanced Oxidation Processes and biological treatments for wastewater decontamination-A review. *Science of the Total Environment*, 409(20), 4141–4166. <http://doi.org/10.1016/j.scitotenv.2010.08.061>
- Paddon, C. J., & Keasling, J. D. (2014). Semi-synthetic artemisinin: a model for the use of synthetic biology in pharmaceutical development. *Nature Reviews Microbiology*, 12(5), 355–367. <http://doi.org/10.1038/nrmicro3240>
- Pannell, T., Goud, R., Schell, D., & Borole, A. (2016). Effect of fed-batch vs. continuous mode of operation on microbial fuel cell performance treating biorefinery wastewater. *Biochemical Engineering*. Retrieved from <http://www.sciencedirect.com/science/article/pii/S1369703X16301279>
- Pant, D., Arslan, D., Van Bogaert, G., Gallego, Y. A., De Wever, H., Diels, L., & Vanbroekhoven, K. (2013). Integrated conversion of food waste diluted with sewage into volatile fatty acids through fermentation and electricity through a fuel cell. *Environmental Technology*, 34(13–16), 1935–45. <http://doi.org/10.1080/09593330.2013.828763>
- Pant, D., Singh, A., Van Bogaert, G., Gallego, Y. A., Diels, L., & Vanbroekhoven, K. (2011). An introduction to the life cycle assessment (LCA) of bioelectrochemical systems (BES) for sustainable energy and product generation: Relevance and key aspects. *Renewable and Sustainable Energy Reviews*, 15(2), 1305–1313. <http://doi.org/10.1016/j.rser.2010.10.005>

- Parameswaran, P., Zhang, H., Torres, C. I., Rittmann, B. E., & Krajmalnik-Brown, R. (2010). Microbial community structure in a biofilm anode fed with a fermentable substrate: The significance of hydrogen scavengers. *Biotechnology and Bioengineering*, *105*(1), 69–78. <http://doi.org/10.1002/bit.22508>
- Penaud, V., Delgenès, J. P., & Moletta, R. (1999). Thermo-chemical pretreatment of a microbial biomass: Influence of sodium hydroxide addition on solubilization and anaerobic biodegradability. *Enzyme and Microbial Technology*, *25*(3–5), 258–263. [http://doi.org/10.1016/S0141-0229\(99\)00037-X](http://doi.org/10.1016/S0141-0229(99)00037-X)
- Pham, H. T., Boon, N., Aelterman, P., Clauwaert, P., De Schampelaire, L., van Oostveldt, P., ... Verstraete, W. (2008). High shear enrichment improves the performance of the anodophilic microbial consortium in a microbial fuel cell. *Microbial Biotechnology*, *1*(6), 487–496. <http://doi.org/10.1111/j.1751-7915.2008.00049.x>
- Pham, T. H., Rabaey, K., Aelterman, P., Clauwaert, P., De Schampelaire, L., Boon, N., & Verstraete, W. (2006). Microbial Fuel Cells in Relation to Conventional Anaerobic Digestion Technology. *Engineering in Life Sciences*, *6*(3), 285–292. <http://doi.org/10.1002/elsc.200620121>
- Potter, M. C. (1911). Electrical Effects Accompanying the Decomposition of Organic Compounds. *Proceedings of the Royal Society of London*, *84*(571), 260–276.
- Potter, M. C. (1915). Electrical Effects accompanying the Decomposition of Organic Compounds II - Ionisation of the Gases produced during Fermentation. *Proceedings of the Royal Society of London*, *91*(632), 17.
- Prieto-Rodríguez, L., Miralles-Cuevas, S., Oller, I., Agüera, a., Puma, G. L., & Malato, S. (2012). Treatment of emerging contaminants in wastewater treatment plants (WWTP) effluents by solar photocatalysis using low TiO₂ concentrations. *Journal of Hazardous Materials*, *211–212*, 131–137. <http://doi.org/10.1016/j.jhazmat.2011.09.008>
- Prieto-Rodríguez, L., Oller, I., Klamerth, N., Agüera, a., Rodríguez, E. M., & Malato, S. (2013). Application of solar AOPs and ozonation for elimination of micropollutants in municipal wastewater treatment plant effluents. *Water Research*, *47*(4), 1521–1528. <http://doi.org/10.1016/j.watres.2012.11.002>
- Qiao, Y., Li, C. M., Bao, S.-J., Lu, Z., & Hong, Y. (2008). Direct electrochemistry and electrocatalytic mechanism of evolved Escherichia coli cells in microbial fuel cells. *Chemical Communications (Cambridge, England)*, (11), 1290–1292. <http://doi.org/10.1039/b719955d>
- Rabaey, K., Boon, N., Höfte, M., & Verstraete, W. (2005). Microbial phenazine production enhances electron transfer in biofuel cells. *Environmental Science and Technology*, *39*(9), 3401–3408. <http://doi.org/10.1021/es048563o>
- Rabaey, K., Boon, N., Siciliano, S. D., Verstraete, W., & Verhaege, M. (2004). Biofuel Cells Select for Microbial Consortia That Self-Mediate Electron Transfer. *Applied and Environmental Microbiology*, *70*(9), 5373–5382. <http://doi.org/10.1128/AEM.70.9.5373>
- Rabaey, K., & Verstraete, W. (2005). Microbial fuel cells: novel biotechnology for energy generation. *Trends in Biotechnology*, *23*, 291–8. <http://doi.org/10.1016/j.tibtech.2005.04.008>
- Reguera, G., McCarthy, K. D., Mehta, T., Nicoll, J. S., Tuominen, M. T., & Lovley, D. R. (2005). Extracellular electron transfer via microbial nanowires. *Nature*, *435*(7045), 1098–1101. <http://doi.org/10.1038/nature03661>

- Research and Markets. (2016). *Bioelectrochemical Systems Market*. Retrieved from <http://www.researchandmarkets.com/research/nsfnl9/bioelectrochemical>
- Rittmann, B. E., & McCarty, P. L. (2001). *Environmental Biotechnology: Principles and Applications*. *Biotechnology*. Retrieved from <http://books.google.com/books?id=S6CiK7Nh9oIC&printsec=frontcover>
- Rozendal, R. a., Hamelers, H. V. M., Molenkamp, R. J., & Buisman, C. J. N. (2007). Performance of single chamber biocatalyzed electrolysis with different types of ion exchange membranes. *Water Research*, *41*(9), 1984–1994. <http://doi.org/10.1016/j.watres.2007.01.019>
- Rozendal, R. a., Hamelers, H. V. M., Rabaey, K., Keller, J., & Buisman, C. J. N. (2008). Towards practical implementation of bioelectrochemical wastewater treatment. *Trends in Biotechnology*, *26*(8), 450–459. <http://doi.org/10.1016/j.tibtech.2008.04.008>
- Sadhukhan, J., Lloyd, J., Scott, K., & Premier, G. (2016). A critical review of integration analysis of microbial electrosynthesis (MES) systems with waste biorefineries for the production of biofuel and chemical from reuse of. *And Sustainable Energy* Retrieved from <http://www.sciencedirect.com/science/article/pii/S1364032115012678>
- Sasaki, K., Morita, M., Sasaki, D., Hirano, S. ichi, Matsumoto, N., Ohmura, N., & Igarashi, Y. (2011). Methanogenic communities on the electrodes of bioelectrochemical reactors without membranes. *Journal of Bioscience and Bioengineering*, *111*(1), 47–49. <http://doi.org/10.1016/j.jbiosc.2010.08.010>
- SBI Energy. (2012a). *Global Market for Membrane Wastewater Treatment*.
- SBI Energy. (2012b). *Waste to Energy Technologies, Market Size and Growth*.
- Scherson, Y. D., & Criddle, C. S. (2014). Recovery of freshwater from wastewater: Upgrading process configurations to maximize energy recovery and minimize residuals. *Environmental Science and Technology*, *48*(15), 8420–8432. <http://doi.org/10.1021/es501701s>
- Schimmel, J. P., & Schaeffer, S. M. (2012). Microbial control over carbon cycling in soil. *Frontiers in Microbiology*. <http://doi.org/10.3389/fmicb.2012.00348>
- Shizas, I., & Bagley, D. M. (2004). Experimental Determination of Energy Content of Unknown Organics in Municipal Wastewater Streams. *Journal of Energy Engineering*, *130*(2), 45–53. [http://doi.org/10.1061/\(ASCE\)0733-9402\(2004\)130:2\(45\)](http://doi.org/10.1061/(ASCE)0733-9402(2004)130:2(45))
- Sleutels, T. H. J. a, Ter Heijne, A., Buisman, C. J. N., & Hamelers, H. V. M. (2012). Bioelectrochemical systems: An outlook for practical applications. *ChemSusChem*, *5*(6), 1012–1019. <http://doi.org/10.1002/cssc.201100732>
- Sleutels, T., Molenaar, S., Heijne, A., & Buisman, C. (2016). Low Substrate Loading Limits Methanogenesis and Leads to High Coulombic Efficiency in Bioelectrochemical Systems. *Microorganisms*, *4*(1), 7. <http://doi.org/10.3390/microorganisms4010007>
- Smith, A. L., Stadler, L. B., Cao, L., Love, N. G., Raskin, L., & Steven, J. (2014). Navigating Wastewater Energy Recovery Strategies: A Life Cycle Comparison of Wastewater Energy Recovery Strategies : Anaerobic Membrane Bioreactor and High Rate Activated Sludge with Anaerobic Digestion. *Environmental Science & Technology*, (48), 5972–5981.
- SoCalGas. (2013). Biogas and Biomethane.
- Sosnowski, P., Wiczorek, A., & Ledakowicz, S. (2003). Anaerobic co-digestion of sewage sludge and organic fraction of municipal solid wastes. *Advances in Environmental Research*, *7*(3), 609–616. [http://doi.org/10.1016/S1093-0191\(02\)00049-7](http://doi.org/10.1016/S1093-0191(02)00049-7)
- Steinbusch, K. J. J., Hamelers, H. V. M., Schaap, J. D., Kampman, C., & Buisman, C. J. N. (2010). Bioelectrochemical ethanol production through mediated acetate reduction by

- mixed cultures. *Environmental Science and Technology*, 44(1), 513–517.
<http://doi.org/10.1021/es902371e>
- Stenuit, B., & Agathos, S. N. (2015). Deciphering microbial community robustness through synthetic ecology and molecular systems synecology. *Current Opinion in Biotechnology*, 33(1), 305–317. <http://doi.org/10.1016/j.copbio.2015.03.012>
- Strycharz-Glaven, S. M., Snider, R. M., Guiseppi-Elie, A., & Tender, L. M. (2011). On the electrical conductivity of microbial nanowires and biofilms. *Energy & Environmental Science*, 4(11), 4366. <http://doi.org/10.1039/c1ee01753e>
- Tan, Y., Adhikari, R. Y., Malvankar, N. S., Ward, J. E., Woodard, T. L., Nevin, K. P., & Lovley, R. (2017). Expressing the *Geobacter metallireducens* PilA in *Geobacter sulfurreducens* Yields Pili with Exceptional Conductivity. *American Society for Microbiology*, 8(1), 1–9.
- Tanaka, S., Kobayashi, T., & Kamiyama, K. (1997). Effects of thermochemical pretreatment on the anaerobic digestion of waste activated sludge. *Water Science and*. Retrieved from <http://www.sciencedirect.com/science/article/pii/S0273122397001698>
- Tartakovsky, B., Mehta, P., Bourque, J. S., & Guiot, S. R. (2011). Electrolysis-enhanced anaerobic digestion of wastewater. *Bioresource Technology*, 102(10), 5685–5691. <http://doi.org/10.1016/j.biortech.2011.02.097>
- Tartakovsky, B., Mehta, P., Santoyo, G., Roy, C., Frigon, J. C., & Guiot, S. R. (2014). Electrolysis-enhanced co-digestion of switchgrass and cow manure. *Journal of Chemical Technology and Biotechnology*, 89(10), 1501–1506. <http://doi.org/10.1002/jctb.4224>
- Tchobanoglous, G., Burton, F. L., & Stensel, H. D. (2003). *Wastewater Engineering: Treatment, Disposal, and Reuse. Metcalf & Eddy, Inc.* (Vol. 4). Retrieved from <http://www.amazon.com/dp/007124140X>
- Tchobanoglous, G., Thiesen, H., & Vigil, S. (1993). *Integrated Solid Waste Management*.
- Ter Heijne, A., Liu, F., Van Rijnsoever, L. S., Saakes, M., Hamelers, H. V. M., & Buisman, C. J. N. (2011). Performance of a scaled-up Microbial Fuel Cell with iron reduction as the cathode reaction. *Journal of Power Sources*, 196(18), 7572–7577. <http://doi.org/10.1016/j.jpowsour.2011.04.034>
- Torres, C., & Marcus, A. K. (2008). Proton transport inside the biofilm limits electrical current generation by anode-respiring bacteria. *Biotechnology and*. Retrieved from <http://onlinelibrary.wiley.com/doi/10.1002/bit.21821/full>
- Tschech, A., & Pfennig, N. (1984). Growth yield increase linked to caffeate reduction in *Acetobacterium woodii*. *Archives of Microbiology*, 137(2), 163–167. <http://doi.org/10.1007/BF00414460>
- US Energy Information Administration. (2017). Electric Power Sector Energy Consumption. Retrieved from <https://www.eia.gov/totalenergy/data/annual/index.php#consumption>
- US EPA. (2017). *Secondary Treatment Regulation 40 CFR 133.102*. Retrieved from https://www.ecfr.gov/cgi-bin/text-idx?SID=dfb6b28d338ccb219b8fb75af2ccb68c&mc=true&node=se40.24.133_1102&rgn=dv8
- USDA, EPA, & DOE. (2014). *Biogas Opportunities Roadmap: Voluntary Actions to Reduce Methane Emissions and Increase Energy Independence*.
- USEPA. (2014). Municipal Solid Waste Generation, Recycling, and Disposal in the United States Tables and Figures for 2012, (February), 63. <http://doi.org/EPA-530-F-14-001>
- Vanwonterghem, I., Jensen, P. D., Rabaey, K., & Tyson, G. W. (2015). Temperature and solids retention time control microbial population dynamics and volatile fatty acid production in

- replicated anaerobic digesters. *Scientific Reports*, 5, 8496. <http://doi.org/10.1038/srep08496>
- Venkata Mohan, S., Velvizhi, G., Vamshi Krishna, K., & Lenin Babu, M. (2014). Microbial catalyzed electrochemical systems: A bio-factory with multi-facet applications. *Bioresource Technology*, 165(September 2015), 355–364. <http://doi.org/10.1016/j.biortech.2014.03.048>
- Verma, S. (2002). Biodegradable Organics in Municipal. *New York*, (May). Retrieved from http://www.seas.columbia.edu/earth/wtert/sofos/Verma_thesis.pdf
- Walter, X. A., Greenman, J., & Ieropoulos, I. A. (2014). Intermittent load implementation in microbial fuel cells improves power performance. *Bioresource Technology*, 172, 365–372. <http://doi.org/10.1016/j.biortech.2014.09.034>
- Water Environment Federation. (2014). *Utilities of the Future Energy Findings*.
- Weaver, S. C., Hensley, D. L., Bierkamp, J., Evans, N., Johnson, W., Biss, B., ... Bhattacharya, P. (2016). Biochar products and production. United States.
- Wei, C.-H., Harb, M., Amy, G., Hong, P.-Y., & Leiknes, T. (2014). Sustainable organic loading rate and energy recovery potential of mesophilic anaerobic membrane bioreactor for municipal wastewater treatment. *Bioresource Technology*, 166C(August 2015), 326–334. <http://doi.org/10.1016/j.biortech.2014.05.053>
- Weiland, P. (2010). Biogas production: current state and perspectives. *Applied Microbiology and Biotechnology*, 85(4), 849–60. <http://doi.org/10.1007/s00253-009-2246-7>
- WERF. (2011). *Energy Management: Expolatory Team Report Executive Summary*.
- Willis, J., Stone, L., Durden, K., Beecher, N., Hemenway, C., & Greenwood, R. (2012). *Barriers to Biogas Use for Renewable Energy*.
- Winkler, W., & Nehter, P. (2008). Thermodynamics of fuel cells. *Modeling Solid Oxide Fuel Cells*, 25–37. http://doi.org/10.1007/978-1-4020-6995-6_2
- World Bank Group. (2017). *Water & Sanitation PPPs*.
- Yu, B., Xu, J., Yuan, H., Lou, Z., Lin, J., & Zhu, N. (2014). Enhancement of anaerobic digestion of waste activated sludge by electrochemical pretreatment. *Fuel*, 130, 279–285. <http://doi.org/10.1016/j.fuel.2014.04.031>
- Yuan, H., Wang, Y., Kobayashi, N., Zhao, D., & Xing, S. (2015). Study of Fuel Properties of Torrefied Municipal Solid Waste. *Energy & Fuels*, 29(8), 4976–4980. <http://doi.org/10.1021/ef502277u>
- Zamalloa, C., Arends, J. B. A., Boon, N., & Verstraete, W. (2013). Performance of a lab-scale bio-electrochemical assisted septic tank for the anaerobic treatment of black water. *New Biotechnology*, 30(5), 573–580. <http://doi.org/10.1016/j.nbt.2013.01.009>
- Zehr, J. P., & Ward, B. B. (2002). Nitrogen cycling in the ocean: New perspectives on processes and paradigms. *Applied and Environmental Microbiology*. <http://doi.org/10.1128/AEM.68.3.1015-1024.2002>
- Zhang, Y., & Angelidaki, I. (2014). Microbial electrolysis cells turning to be versatile technology: Recent advances and future challenges. *Water Research*, 56(November 2015), 11–25. <http://doi.org/10.1016/j.watres.2014.02.031>
- Zhen, G., Lu, X., Li, Y. Y., & Zhao, Y. (2014). Combined electrical-alkali pretreatment to increase the anaerobic hydrolysis rate of waste activated sludge during anaerobic digestion. *Applied Energy*, 128, 93–102. <http://doi.org/10.1016/j.apenergy.2014.04.062>
- Zinder, S. (1993). Physiological Ecology of Methanogens. In *Methanogens: Ecology, Physiology, Biochemistry & Genetics*. <http://doi.org/10.1007/978-1-4615-2391-8>
- Zomorodi, A. R., & Segre, D. (2016). Synthetic Ecology of Microbes: Mathematical Models and Applications. *Journal of Molecular Biology*. <http://doi.org/10.1016/j.jmb.2015.10.019>

Appendix

Microbial Fuel Cell Calculations

$$Eq. 32 \quad I_{MFC} = \frac{1000gCOD}{L*Day} * 85\% \text{ biomass} * \frac{mol}{32gCOD} * \frac{4e^-}{mol} * \frac{96485 \text{ Coloumb}}{e^-} * \frac{1day}{86400seconds} = 118.6 A$$

$$Eq. 33 \quad \Delta G'_{an} = 2HCO_3^- + 9H^+ + 8e^- \rightarrow CH_3COO^- + 4H_2O = -144.34 \text{ kJ/mol}$$

$$Eq. 34 \quad V'_{an} = -\frac{\Delta G'_{an}}{8*96485} = 0.187 V$$

$$Eq. 35 \quad V_{an} = V'_{an} - \frac{RT}{8F} \ln \left(\frac{[CH_3COO^-]}{[HCO_3^-]^2[H^+]^9} \right) = -0.296V$$

Similarly, the Gibb's free energy and half-cell potential are needed for the Nernst equation at the cathode. The number of electrons involved in this reaction is 4, the pH is 7, and the partial pressure of oxygen is 0.2 bar.

$$Eq. 36 \quad \Delta G'_{cat} = O_2 + 4H^+ + 4e^- \rightarrow 2H_2O = -474.3 \text{ kJ/mol}$$

$$Eq. 37 \quad V'_{cat} = -\frac{\Delta G'_{cat}}{4*96485} = 1.229 V$$

$$Eq. 38 \quad V_{cat} = V'_{cat} - \frac{RT}{4F} \ln \left(\frac{1}{pO_2[H^+]^4} \right) = 0.805 V$$

The whole cell voltage is calculated by the difference of the cathode and anode. The efficiency of an MFC system is estimated by dividing the expected electrical energy produced by the chemical energy of acetate.

$$Eq. 39 \quad V_{MFC} = V_{cat} - V_{an} = 1.101 V$$

$$Eq. 40 \quad E_{MFC} = I_{MFC} * V_{MFC} * \frac{24hr}{\left(\frac{1000W}{1kW}\right)} = 3.135 \text{ kWh}$$

$$Eq. 41 \quad E_{Acetate} = 3.778 \text{ kWh}$$

$$Eq. 42 \quad \eta_{MFC} = \frac{E_{MFC}}{E_{acetate}} = 82.98\% \text{ efficiency}$$

Microbial Electrolysis Cell Calculations

$$Eq. 43 \quad I_{MEC} = 118.6 A$$

$$Eq. 44 \quad Y_{H_2} = 1.192 \text{ m}^3 H_2$$

The Gibb's free energy and half-cell potential at the anode are determined to be used in the Nernst equation. The conditions in this half-cell reaction are like those in the MFC reactor. However, the acetate and bicarbonate concentrations are assumed to be double in the MEC configuration.(S. Cheng & Hamelers, 2008)

$$Eq. 45 \quad \Delta G'_{an} = 2HCO_3^- + 9H^+ + 8e^- \rightarrow CH_3COO + 4H_2O = -144.34 \text{ kJ/mol}$$

$$Eq. 46 \quad V'_{an} = -\frac{\Delta G'_{an}}{8 \cdot 96485} = 0.187 V$$

$$Eq. 47 \quad V_{an} = V'_{an} - \frac{RT}{8F} \ln \left(\frac{[CH_3COO^-]}{[HCO_3^-]^2 [H^+]^9} \right) = -0.276 V$$

Again, the Gibb's free energy and half-cell potential are needed for the Nernst equation at the cathode. The number of electrons involved in this reaction is 2, the pH is 7, and the partial pressure of hydrogen is 1 bar.

$$Eq. 48 \quad \Delta G'_{cat} = 2H^+ + 2e^- \rightarrow H_2 = 0 \text{ kJ/mol}$$

$$Eq. 49 \quad V'_{cat} = -\frac{\Delta G'_{cat}}{2 \cdot 96485} = 0 V$$

$$Eq. 50 \quad V_{cat} = V'_{cat} - \frac{RT}{2F} \ln \left(\frac{p_{H_2}}{[H^+]^2} \right) = -0.414 V$$

The applied voltage required for hydrogen production is calculated from the whole cell voltage. It is a negative value, which indicates that energy must be supplied to the MEC. The energy efficiency of the MEC is estimate by dividing the electrical energy potential of hydrogen gas by the sum of the chemical energy of acetate and the applied electrical energy. The electrical energy produced is achieved by a proton exchange membrane fuel cell (PEMFC) operating at a theoretical efficiency of 83%.

$$Eq. 51 \quad V_{MEC} = V_{cat} - V_{an} = -0.138 V = V_{app}$$

$$Eq. 52 \quad E_{MEC} = Y_{H_2} * \frac{3.29 kWh}{m^3 H_2} * 83\% \text{ PEMFC} = 3.25 kWh$$

$$Eq. 53 \quad E_{app} = V_{app} * I_{MEC} * \frac{24hr}{\frac{1000W}{1kW}} = -0.39 kWh$$

$$Eq. 54 \quad \eta_{MEC} = \frac{E_{MEC}}{E_{acetate} + E_{app}} = 78.01\%$$

Anaerobic Digestion Calculations

$$Eq. 55 \quad Y_{CH_4} = \frac{1,000 \text{ gCOD}}{\text{day}} * 88\% \text{ current} * \frac{1 \text{ molCH}_4}{64 \text{ gCOD}} * \frac{16.04 \text{ gCH}_4}{\text{molCH}_4} * \frac{1 \text{ LCH}_4}{0.656 \text{ gCH}_4} * \frac{1 \text{ m}^3 \text{ CH}_4}{1000 \text{ LCH}_4} = 0.34 \frac{\text{m}^3}{\text{day}}$$

$$Eq. 56 \quad E_{AD} = \frac{0.34 \text{ m}^3}{\text{day}} * \frac{10.35 kWh}{\text{m}^3} * 38\% \text{ efficiency} * 1 \text{ day} = 1.337 kWh$$

$$Eq. 57 \quad \eta_{AD} = \frac{E_{AD}}{E_{acetate}} = 35.39\%$$

Table 6. Proximate and Energy Analysis of Food Waste (Modified from Tchobanoglous 1993)

Waste Type	Feedstock Characteristics*			Energy Content (kWh/kg)	
	Moisture Content (%)	Volatile Matter (%)	Fixed Carbon (%)	As Collected	Dry
<i>Food and Food Products</i>					
Fats	2.0	95.3	2.5	10.42	10.64
Mixed Food Waste	70.0	21.4	3.6	1.16	3.87
Fruits and Vegetables	78.7	16.6	4.0	1.10	5.18
Meat Wastes	28.8	56.4	1.8	4.93	8.05

*Proximate analysis may not add to 100%. Residual content is ash

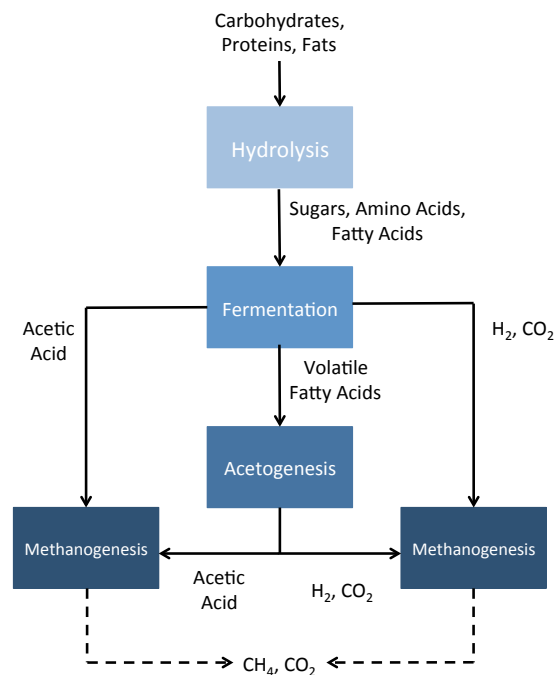

Figure 18. Steps of Anaerobic Digestion (Modified from Li 2011)

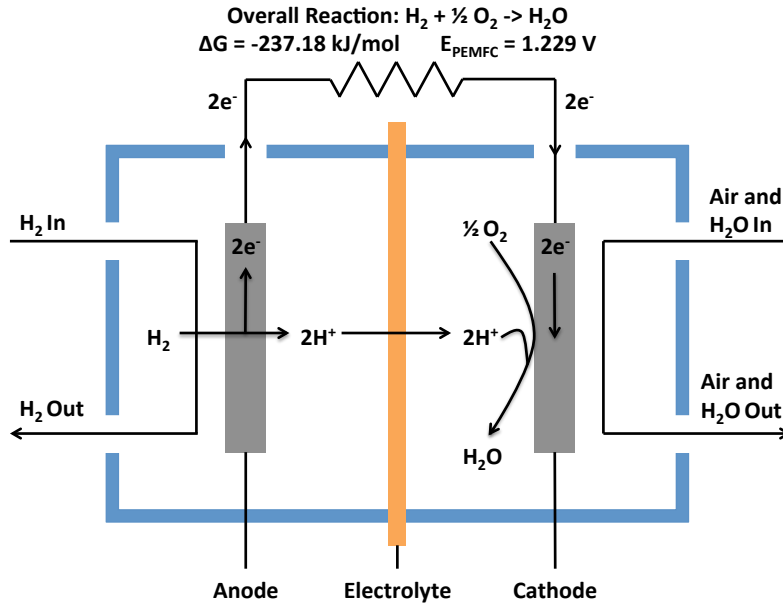

Figure 19. Schematic of Basic Fuel Cell Design

Table 7. Theoretical Energy Recovery from Acetate

Theoretical Energy Recovery from Acetate (kWh)						
Configuration	Acetate Energy Content (kWh)	Anaerobic Digestion*	Microbial Fuel Cell	Microbial Electrolysis Cell**	Energy Input	Energy Efficiency (electricity recovery)
AD Only	3.78	1.34	-	-	-	35.39
MFC Only	3.78	-	3.14	-	-	82.98
MEC Only	3.78	-	-	3.25	0.39	78.01
ADMFC	3.78	1.07	0.63	-	-	44.89
ADMEC	3.78	1.07	-	0.65	0.08	44.58

* Including Methane to electricity conversion at 38%

** Including Hydrogen to electricity conversion at 83%

Table 8. Practical Energy Recovery from Acetate

Practical Energy Recoveries from Acetate (kWh)						
Configuration	Acetate Energy Content	Anaerobic Digestion*	Microbial Fuel Cell	Microbial Electrolysis Cell**	Energy Input	Energy Efficiency (electricity recovery)
AD Only	3.78	1.26	-	-	-	33.33
MFC Only	3.78	-	1.71	-	-	45.23
MEC Only	3.78	-	-	1.63	1.71	29.69
ADMFC	3.78	1.01	0.34	-	-	35.71
ADMEC	3.78	1.01	-	0.33	0.34	32.52

* Including Methane to electricity conversion at 38%

** Including Hydrogen to electricity conversion at 83%

Table 9. Practical Energy Recovery from Food Waste

Practical Energy Recovery from Food Waste (kWh)						
Configuration	Waste Energy Content (kWh)	Anaerobic Digestion*	Microbial Fuel Cell	Microbial Electrolysis Cell**	Energy Input	Energy Efficiency (electricity recovery)
AD Only	2.95	0.67	-	-	-	22.61
MFC Only	2.95	-	0.91	-	-	30.69
MEC Only	2.95	-	-	0.86	0.91	22.36
ADMFC	2.95	0.54	0.18	-	-	24.41
ADMEC	2.95	0.54	-	0.17	0.18	22.68

Biodegradability Factor 53%

* Including Methane to electricity conversion at 38%

** Including Hydrogen to electricity conversion at 60%

Table 10. Practical Energy Recovery from Sewage Sludge

Practical Energy Recovery from Sewage Sludge (kWh)						
Configuration	Waste Energy Content (kWh)	Anaerobic Digestion*	Microbial Fuel Cell	Microbial Electrolysis Cell**	Energy Input	Energy Efficiency (electricity recovery)
AD Only	4.08	0.79	-	-	-	19.36
MFC Only	4.08	-	1.08	-	-	26.38
MEC Only	4.08	-	-	1.03	1.08	19.96
ADMFC	4.08	0.63	0.22	-	-	20.83
ADMEC	4.08	0.63	-	0.21	0.22	19.53

Biodegradability Factor 63%

* Including Methane to electricity conversion at 38%

** Including Hydrogen to electricity conversion at 83%

Table 11. One-Kilogram Analysis of Food Waste and Wastewater Solids

Waste Type	Proximate Analysis*					Energy Content (kWh)
	Moisture Content (g)	Total Solids (g)	Volatile Solids (g)	COD (g)	sCOD (g)	Per kg COD
Food Waste ^a	1,781	763	544	1,000	463	2.90
Wastewater Solids ^b	22,563	698	468	1,000	500	2.00

a Data from Tchobanoglous 1993 and Cho 2013

b Data from Heidrich 2010

Table 12. Summary of Economic Model Variables

Plant Capacity	Capacity (vol/day)		COD (g/L)	COD/d		COD Conversion
	gal/d	200000.00	0.3	227124.60	g/d	kWh/day
	l/d	757082.00		227.12	kg/d	25.42
	m ³ /d	757.08		0.23	ton/d	kWh/yr
						200435.55
CAPEX	Cap Costs (\$/m ³ or \$/ton)		factor (ton COD or M ³)	Costs	Ref	kWh/kg
	AD	100000	0.23	(22,712.46)	Pham 2006	0.112
	MFC	1220	11.35	(13,847.00)	Escapa 2012	\$/kg COD
	MEC	1220	11.35	(13,847.00)	Escapa 2012	0.012
	ADMFC	-	-	(20,939.37)	Mixed costs	
	ADMEC	-	-	(20,939.37)	Mixed costs	
Annual O&M	O&M	Cost (\$/kg COD)	Annual Loading	Annual O&M	Ref	
	MFC	0.05	82900.479	4,145.02	Sleutels 2012	* O&M costs for AD are based on dry tonnage of sludge COD from the WRRF. Annual loading for AD is based on tonnage.
	MEC	0.11	82900.479	9,119.05	Sleutels 2012	
	AD *	0.048	82900.479	3,979.22	Moriarty 2013	
	ADMFC			4,012.38	Mixed costs	
	ADMEC			5,007.19	Mixed costs	
Annual Revenue	Efficiency	Energy Resource (kWh/yr)	Energy Output (kWh/yr)	Product Price (\$/kWh)	Annual Revenue (\$)	
	AD	0.19	200,435.55	38,082.75	\$0.03	\$1,299.44
	MFC	0.13	200,435.55	26,056.62	\$0.06	\$1,599.88
	MEC	0.2	200,435.55	40,087.11	\$0.10	\$4,008.71
	ADMFC	0.18	200,435.55	36,078.40	\$0.04	\$1,427.88
	ADMEC	0.19	200,435.55	38,082.75	\$0.05	\$1,801.20

Table 13. Net-Present Value for AD Process

Yr	AD Rev	O&M	Cash Flow	Present Value	20-yr NPV
0	\$0.00	\$0.00	\$0.00	(22,712.46)	(71,070.68)
1	\$1,299.44	3,979.22	(\$2,653.25)	(\$2,653.25)	
2	\$1,299.44	3,979.22	(\$2,626.98)	(\$2,626.98)	
3	\$1,299.44	3,979.22	(\$2,600.97)	(\$2,600.97)	
4	\$1,299.44	3,979.22	(\$2,575.22)	(\$2,575.22)	
5	\$1,299.44	3,979.22	(\$2,549.72)	(\$2,549.72)	
6	\$1,299.44	3,979.22	(\$2,524.48)	(\$2,524.48)	
7	\$1,299.44	3,979.22	(\$2,499.48)	(\$2,499.48)	
8	\$1,299.44	3,979.22	(\$2,474.74)	(\$2,474.74)	
9	\$1,299.44	3,979.22	(\$2,450.24)	(\$2,450.24)	
10	\$1,299.44	3,979.22	(\$2,425.98)	(\$2,425.98)	
11	\$1,299.44	3,979.22	(\$2,401.96)	(\$2,401.96)	
12	\$1,299.44	3,979.22	(\$2,378.17)	(\$2,378.17)	
13	\$1,299.44	3,979.22	(\$2,354.63)	(\$2,354.63)	
14	\$1,299.44	3,979.22	(\$2,331.31)	(\$2,331.31)	
15	\$1,299.44	3,979.22	(\$2,308.23)	(\$2,308.23)	
16	\$1,299.44	3,979.22	(\$2,285.38)	(\$2,285.38)	
17	\$1,299.44	3,979.22	(\$2,262.75)	(\$2,262.75)	
18	\$1,299.44	3,979.22	(\$2,240.35)	(\$2,240.35)	
19	\$1,299.44	3,979.22	(\$2,218.17)	(\$2,218.17)	
20	\$1,299.44	3,979.22	(\$2,196.20)	(\$2,196.20)	

Table 14. Net-Present Value for MFC Process

Yr	MFC Rev	O&M	Cash Flow	Present Value	20-yr NPV
0	\$0.00	\$0.00	\$0.00	(13,847.00)	(59,775.59)
1	\$1,599.88	4,145.02	(\$2,519.95)	(\$2,519.95)	
2	\$1,599.88	4,145.02	(\$2,495.00)	(\$2,495.00)	
3	\$1,599.88	4,145.02	(\$2,470.30)	(\$2,470.30)	
4	\$1,599.88	4,145.02	(\$2,445.84)	(\$2,445.84)	
5	\$1,599.88	4,145.02	(\$2,421.62)	(\$2,421.62)	
6	\$1,599.88	4,145.02	(\$2,397.64)	(\$2,397.64)	
7	\$1,599.88	4,145.02	(\$2,373.90)	(\$2,373.90)	
8	\$1,599.88	4,145.02	(\$2,350.40)	(\$2,350.40)	
9	\$1,599.88	4,145.02	(\$2,327.13)	(\$2,327.13)	
10	\$1,599.88	4,145.02	(\$2,304.09)	(\$2,304.09)	
11	\$1,599.88	4,145.02	(\$2,281.28)	(\$2,281.28)	
12	\$1,599.88	4,145.02	(\$2,258.69)	(\$2,258.69)	
13	\$1,599.88	4,145.02	(\$2,236.33)	(\$2,236.33)	
14	\$1,599.88	4,145.02	(\$2,214.18)	(\$2,214.18)	
15	\$1,599.88	4,145.02	(\$2,192.26)	(\$2,192.26)	
16	\$1,599.88	4,145.02	(\$2,170.56)	(\$2,170.56)	
17	\$1,599.88	4,145.02	(\$2,149.07)	(\$2,149.07)	
18	\$1,599.88	4,145.02	(\$2,127.79)	(\$2,127.79)	
19	\$1,599.88	4,145.02	(\$2,106.72)	(\$2,106.72)	
20	\$1,599.88	4,145.02	(\$2,085.86)	(\$2,085.86)	

Table 15. Net-Present Value for MEC Process

Yr	MEC Rev	O&M	Cash Flow	Present Value	20-yr NPV
0	\$0.00	\$0.00	\$0.00	(13,847.00)	(57,354.22)
1	\$4,008.71	9,119.05	(\$4,645.77)	(\$4,645.77)	
2	\$4,008.71	9,119.05	(\$4,223.42)	(\$4,223.42)	
3	\$4,008.71	9,119.05	(\$3,839.48)	(\$3,839.48)	
4	\$4,008.71	9,119.05	(\$3,490.43)	(\$3,490.43)	
5	\$4,008.71	9,119.05	(\$3,173.12)	(\$3,173.12)	
6	\$4,008.71	9,119.05	(\$2,884.65)	(\$2,884.65)	
7	\$4,008.71	9,119.05	(\$2,622.41)	(\$2,622.41)	
8	\$4,008.71	9,119.05	(\$2,384.01)	(\$2,384.01)	
9	\$4,008.71	9,119.05	(\$2,167.28)	(\$2,167.28)	
10	\$4,008.71	9,119.05	(\$1,970.26)	(\$1,970.26)	
11	\$4,008.71	9,119.05	(\$1,791.14)	(\$1,791.14)	
12	\$4,008.71	9,119.05	(\$1,628.31)	(\$1,628.31)	
13	\$4,008.71	9,119.05	(\$1,480.28)	(\$1,480.28)	
14	\$4,008.71	9,119.05	(\$1,345.71)	(\$1,345.71)	
15	\$4,008.71	9,119.05	(\$1,223.38)	(\$1,223.38)	
16	\$4,008.71	9,119.05	(\$1,112.16)	(\$1,112.16)	
17	\$4,008.71	9,119.05	(\$1,011.05)	(\$1,011.05)	
18	\$4,008.71	9,119.05	(\$919.14)	(\$919.14)	
19	\$4,008.71	9,119.05	(\$835.58)	(\$835.58)	
20	\$4,008.71	9,119.05	(\$759.62)	(\$759.62)	

Table 16. Net-Present Value for ADMFC Process

Yr	ADMFC Rev	O&M	Cash Flow	Present Value	20-yr NPV
0	\$0.00	\$0.00	\$0.00	(20,939.37)	(42,942.71)
1	\$1,427.88	4,012.38	(\$2,349.55)	(\$2,349.55)	
2	\$1,427.88	4,012.38	(\$2,135.95)	(\$2,135.95)	
3	\$1,427.88	4,012.38	(\$1,941.78)	(\$1,941.78)	
4	\$1,427.88	4,012.38	(\$1,765.25)	(\$1,765.25)	
5	\$1,427.88	4,012.38	(\$1,604.77)	(\$1,604.77)	
6	\$1,427.88	4,012.38	(\$1,458.89)	(\$1,458.89)	
7	\$1,427.88	4,012.38	(\$1,326.26)	(\$1,326.26)	
8	\$1,427.88	4,012.38	(\$1,205.69)	(\$1,205.69)	
9	\$1,427.88	4,012.38	(\$1,096.08)	(\$1,096.08)	
10	\$1,427.88	4,012.38	(\$996.44)	(\$996.44)	
11	\$1,427.88	4,012.38	(\$905.85)	(\$905.85)	
12	\$1,427.88	4,012.38	(\$823.50)	(\$823.50)	
13	\$1,427.88	4,012.38	(\$748.64)	(\$748.64)	
14	\$1,427.88	4,012.38	(\$680.58)	(\$680.58)	
15	\$1,427.88	4,012.38	(\$618.71)	(\$618.71)	
16	\$1,427.88	4,012.38	(\$562.46)	(\$562.46)	
17	\$1,427.88	4,012.38	(\$511.33)	(\$511.33)	
18	\$1,427.88	4,012.38	(\$464.85)	(\$464.85)	
19	\$1,427.88	4,012.38	(\$422.59)	(\$422.59)	
20	\$1,427.88	4,012.38	(\$384.17)	(\$384.17)	

Table 17. Net-Present Value for ADMEC Process

Yr	ADMEC Rev	O&M	Cash Flow	Present Value	20-yr NPV
0	\$0.00	\$0.00	\$0.00	(20,939.37)	(48,233.72)
1	\$1,801.20	5,007.19	(\$2,914.53)	(\$2,914.53)	
2	\$1,801.20	5,007.19	(\$2,649.57)	(\$2,649.57)	
3	\$1,801.20	5,007.19	(\$2,408.70)	(\$2,408.70)	
4	\$1,801.20	5,007.19	(\$2,189.73)	(\$2,189.73)	
5	\$1,801.20	5,007.19	(\$1,990.66)	(\$1,990.66)	
6	\$1,801.20	5,007.19	(\$1,809.69)	(\$1,809.69)	
7	\$1,801.20	5,007.19	(\$1,645.18)	(\$1,645.18)	
8	\$1,801.20	5,007.19	(\$1,495.62)	(\$1,495.62)	
9	\$1,801.20	5,007.19	(\$1,359.65)	(\$1,359.65)	
10	\$1,801.20	5,007.19	(\$1,236.05)	(\$1,236.05)	
11	\$1,801.20	5,007.19	(\$1,123.68)	(\$1,123.68)	
12	\$1,801.20	5,007.19	(\$1,021.53)	(\$1,021.53)	
13	\$1,801.20	5,007.19	(\$928.66)	(\$928.66)	
14	\$1,801.20	5,007.19	(\$844.24)	(\$844.24)	
15	\$1,801.20	5,007.19	(\$767.49)	(\$767.49)	
16	\$1,801.20	5,007.19	(\$697.72)	(\$697.72)	
17	\$1,801.20	5,007.19	(\$634.29)	(\$634.29)	
18	\$1,801.20	5,007.19	(\$576.62)	(\$576.62)	
19	\$1,801.20	5,007.19	(\$524.20)	(\$524.20)	
20	\$1,801.20	5,007.19	(\$476.55)	(\$476.55)	

Table 18. Carbon Intensity of Fuel Sources

Energy Source	Coal	Nuclear	Natural Gas	Renewables	Petroleum
Energy Mix (%)	46	21	20	13	1
Carbon Intensity (kgCO ₂ /kWh-e)	1.58	~0	0.88	~0	1.18

*From EIA *Primary Consumption and Carbon Coefficients*.

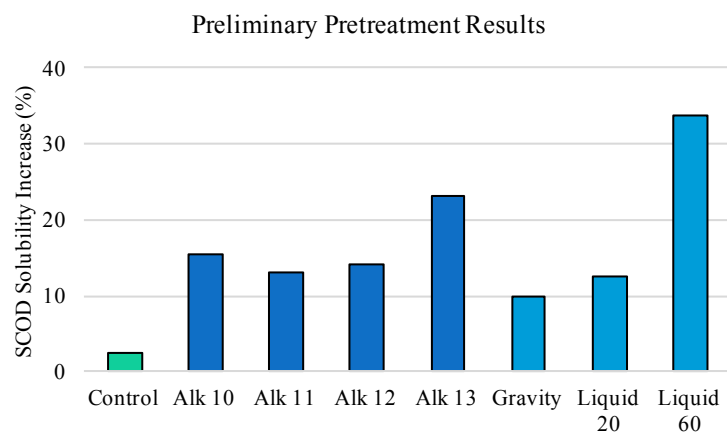

Figure 20. Effects of Alkaline and Thermal Hydrolysis Pretreatment on soluble COD in small-scale preliminary tests

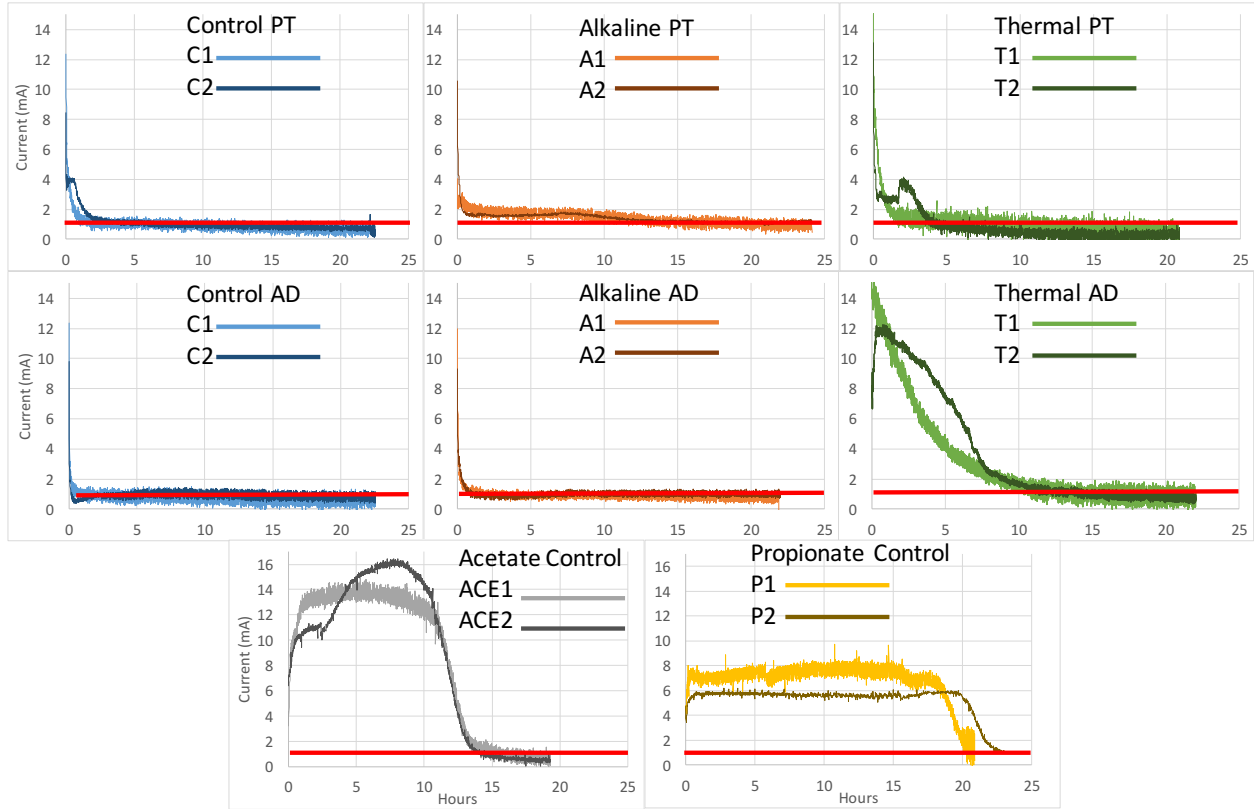

Figure 21. Electrochemical Data from MEC Experiments. Top Row: Pretreatment Soluble Phase (Control, Alkaline, and Thermal), Middle Row: Anaerobic Digester Effluent (Control, Alkaline, and Thermal). Bottom Row: Acetate and Propionate Controls

Table 19. ADMEC Experiment Data for COD Balance

	COD ₀ (g)	PT		AD				MEC AD			MEC PT			Total	
		SCOD	PCOD	SCOD	PCOD	Electrons	Methane	SCOD	Electrons	Biomass	SCOD	Electrons	Biomass	Electrons	
Control	C1	1.00	0.130	0.870	0.217	0.211	0.377	0.199	0.150	0.050	0.011	-0.005	0.128	0.007	0.377
	C2	1.00	0.130	0.870	0.168	0.260	0.337	0.199	0.050	0.110	0.008	0.102	0.028	0.007	0.337
Alkaline	A1	1.00	0.320	0.680	0.240	0.211	0.087	0.039	0.220	0.010	0.012	0.265	0.039	0.016	0.087
	A2	1.00	0.320	0.680	0.238	0.213	0.211	0.039	0.150	0.080	0.012	0.228	0.092	0.016	0.211
Thermal	T1	1.00	0.270	0.730	0.215	0.242	0.234	0.069	0.050	0.150	0.011	0.241	0.015	0.014	0.234
	T2	1.00	0.270	0.730	0.173	0.284	0.159	0.069	0.080	0.080	0.009	0.260	0.010	0.014	0.159

Table 20. COD Balance Summary

COD ₀ (g)	PT		AD				MEC AD			MEC PT			Total	
	SCOD	PCOD	SCOD	PCOD	Biomass	Methane	SCOD	Electrons	Biomass	SCOD	Electrons	Biomass	Electrons	
Control	1.00	0.130	0.870	0.19	0.24	0.240	0.200	0.10	0.08	0.01	0.05	0.08	0.007	0.357
		± 0.00	± 0.00	± 0.02	± 0.02	± 0.00	± 0.00	± 0.05	± 0.03	± 0.002	± 0.05	± 0.05	± 0.00	± 0.02
Alkaline	1.00	0.320	0.680	0.24	0.21	0.190	0.040	0.19	0.04	0.012	0.24	0.07	0.016	0.149
		± 0.00	± 0.00	± 0.00	± 0.00	± 0.00	± 0.00	± 0.03	± 0.03	± 0.00	± 0.03	± 0.03	± 0.00	± 0.06
Thermal	1.00	0.270	0.730	0.19	0.26	0.200	0.070	0.07	0.12	0.010	0.24	0.01	0.014	0.196
		± 0.00	± 0.00	± 0.02	± 0.02	± 0.00	± 0.00	± 0.02	± 0.04	± 0.001	± 0.00	± 0.00	± 0.00	± 0.04

Table 21. Energy Production Summary

Substrate	Anaerobic Digestion			MEC PT			MEC AD			Total Energy		
	Energy (J/gCOD*d)	SCOD Fed	Total Energy	Energy (J/gCOD*d)	SCOD Fed	Total Energy	Energy (J/gCOD*d)	SCOD Fed	Total Energy	Energy	Average Energy	ST Dev
C1	2,755.20	0.87	2,397.02	638.17	0.13	82.96	835.68	0.22	181.24	2,661.23	2,699.93	38.70
C2	2,755.20	0.87	2,397.02	421.38	0.13	54.78	1,709.72	0.17	286.83	2,738.63		
A1	688.80	0.68	468.38	699.96	0.32	223.99	724.07	0.24	173.76	866.13	1,028.31	162.18
A2	688.80	0.68	468.38	841.90	0.32	269.41	1,904.04	0.24	452.69	1,190.48		
T1	1,136.52	0.73	829.66	623.85	0.27	168.44	7,006.99	0.21	1,504.51	2,502.61	2,466.52	36.09
T2	1,136.52	0.73	829.66	966.30	0.27	260.90	7,762.12	0.17	1,339.87	2,430.44		

Vita

Jeff Beegle was born in Cleveland, Ohio to Amy and Kevin Beegle. He is the older brother of Peter and Heather. He attended Hudson High School in Hudson, Ohio where he fell in love with the sciences, notably biology and physics. During high school, Jeff also played ice hockey and percussion. After high school, Jeff attended the University of Toledo where he studied bioengineering. At the University of Toledo, Jeff pursued minors in biology and renewable energy, which led him to extracurricular groups like Building Ohio's Sustainable Energy Future (BOSEF) and to co-founding the University of Toledo Student Green Fund. During undergrad, Jeff also completed two engineering internships at Terumo Cardiovascular Systems in Ann Arbor, MI and one internship with the University of Toledo environmental engineering department. After obtaining his BS in Bioengineering, Jeff was accepted into the Bredesen Center, Energy Science and Engineering PhD program at the University of Tennessee. While completing his graduate research, Jeff co-founded a startup called Grow Bioplastics, LLC with fellow Bredesen Student and University of Toledo graduate, Tony Bova. Jeff transferred to the University of Tennessee Microbiology department to conclude his graduate research while continuing his entrepreneurship pursuits. Jeff graduated from the University of Tennessee with his Master's in Microbiology in May 2017. He is continuing to work with Grow Bioplastics and developing new products and technologies that capitalize on waste-to-value models.