

To the Graduate Council:

I am submitting herewith a thesis written by Martha Maria Malapi Nelson entitled “Interactions between *Alfalfa mosaic virus* and *Soybean mosaic virus* in soybean”. I have examined the final electronic copy of this thesis for form and content and recommend that it be accepted in partial fulfillment of the requirements for the degree of Master of Science, with a major in Entomology and Plant Pathology.

M. R. Hajimorad  
Major Professor

We have read this dissertation  
and recommend its acceptance:

Ernest C. Bernard

Kimberly D. Gwinn

Bonnie H. Ownley

Accepted for the Council:

Carolyn R. Hodges  
Vice Provost and Dean of the Graduate School

(Original signatures are on file with official student records.)

**Interactions between *Alfalfa mosaic virus*  
and *Soybean mosaic virus*  
in soybean**

A Thesis

Presented for the

Master of Science

Degree

The University of Tennessee, Knoxville

Martha Maria Malapi Nelson

Aug. 2008

## **Dedication**

This dissertation is dedicated to my little daughter, Alessia A. Malapi, who inspired me to look for a better future for both of us, and to my mother Martha Nelson who always believed in me.

## **Acknowledgments**

I wish to thank all those who helped me complete my Master of Science degree. Thanks to Dr. Reza Hajimorad for his guidance at any time. I would like to thank Dr. Ownley for helping me with the statistical analysis of my research, and Dr. Bernard and Dr. Gwinn for their moral support and assistance at any time.

I would also like to thank Dr. Jason P. Wight for his efforts to correct the grammar in all my homework, papers and thesis during my studies, as well as for his continuous love and friendship. Thank you, Jason, for being there for me all the time.

Lastly, I would like to thank my father Alcibiades, and my brothers, Alci and Fernando, whose suggestions and encouragements made this work possible.

## Abstract

Viral synergism occurs when two or more unrelated viruses simultaneously infect the same plant and the multiplication of one of the viruses is enhanced. This is generally associated with no change(s) in multiplication of the other viruses involved. Synergism also results in intensification of symptoms. In mixed-infection, viruses may also interact in an antagonistic manner, where one virus suppresses the replication or accumulation of another virus. This phenomenon is uncommon, and only two cases have been reported where the coat protein (CP) accumulation of one of the viruses has decreased. A number of synergistic interactions studied involve viruses belonging to the *Potyviridae* family. The increase in CP accumulation of the non-potyvirus in such an interaction has been attributed to the effect of the helper-component proteinase (HC-Pro) of potyviruses. Plant antiviral defense mechanism called “gene silencing”. HC-Pro is known as a strong suppressor of gene silencing and represents the first identified and characterized plant viral suppressor of gene silencing. The ability of *Soybean mosaic virus* (SMV), a member of the *Potyviridae* family, to interact synergistically with *Bean pod mottle virus* (BPMV) and *Cowpea mosaic virus* (CPMV) in mixed-infection in soybean has been demonstrated, but no change in the level of accumulation of CP of SMV was reported. In addition to SMV, soybean is infected by many other potyviruses or non-potyvirus, including *Alfalfa mosaic virus* (AMV). This research was aimed at studying the interaction of SMV with AMV in mixed-infection in soybean. Two biologically distinct SMV strains and three AMV isolates were used in this study and their interactions in mixed-infection in two different cultivars of soybeans (Williams 82 and Lee 68) were investigated. It was

demonstrated that (a) mixed-infection between AMV and SMV can be easily established, irrespective of sequential or simultaneous inoculation of the two viruses; (b) based on CP accumulation and disease phenotype, AMV interaction with SMV is synergistic resulting in enhancement in symptom severity and AMV CP accumulation; (c) synergistic interaction of AMV with SMV is strain and cultivar independent; (d) interaction of SMV with AMV is antagonistic, which is also strain and soybean cultivar-independent.

## Table of contents

<b>Chapter I: Introduction</b> .....	1
1.1. Mixed viral infections .....	1
1.2. Viral interactions in mixed-infection .....	2
A. Antagonistic interactions.....	2
B. Synergistic interactions .....	3
1.3. Gene silencing.....	6
1.4. Viral suppressors of gene silencing .....	7
A. HC-Pro cistron of potyviruses as a suppressor of gene silencing .....	8
1.5. SMV and AMV in soybean.....	9
1.6. Economic importance of soybean.....	11
1.7. Research objectives.....	12
References cited .....	14
Appendix 1: Tables .....	22
<b>Chapter II: Properties of selected strains of AMV and SMV from soybean</b> .....	26
Abstract.....	27
2.1. Introduction.....	28
2.2. Materials and methods .....	29
A. Soybean genotypes, virus inoculation and propagation.....	29
B. Viruses.....	31
C. Antigen Coated Indirect Enzyme-Linked Immunosorbent Assay .....	32
D. Viral Purification.....	33
E. SDS-PAGE .....	35
F. Western Immuno-blotting.....	36
2.3. Results.....	37
A. Viruses .....	37
2.4. Discussion .....	41
References cited .....	42

Appendix 2: Tables.....	45
Appendix 2: Figures.....	49
<b>Chapter III: Interactions between AMV and SMV in soybean.....</b>	<b>55</b>
Abstract.....	56
3.1. Introduction.....	58
3.2. Materials and methods.....	60
A. Viruses.....	60
B. Evaluation of AMV and SMV CP accumulation in soybean.....	61
C. Mixed-viral infection experiments.....	62
3.3. Results.....	64
A. Establishment of mixed-infection between AMV-JD and SMV-N in soybean cv. Williams 82.....	64
B. Synergism between AMV and SMV is AMV strain independent.....	66
C. Synergism between AMV and SMV is SMV strain independent.....	69
D. Synergism between AMV and SMV is soybean genotype independent.....	72
3.4. Discussion.....	75
3.5. References cited.....	80
Appendix 3: Tables.....	87
Appendix 3: Figures.....	93
VITA.....	109

## List of Tables

<b>Table 1.1.</b> Viral synergistic interactions in different hosts and the resultants synergistic effect.....	22
<b>Table 1.1.</b> Continued .....	23
<b>Table 1.2.</b> Gene products from a number of plants viruses are capable of suppressing gene silencing .....	24
<b>Table 1.3.</b> Viruses that naturally infect soybean in U.S.....	25
<b>Table 2.1.</b> Original hosts, locations and contributors of AMV isolates used in this study .....	45
<b>Table 2.2.</b> Local lesion hosts used for generation of biological clones of AMV isolates. ....	46
<b>Table 2.3.</b> Symptoms induced by AMV isolates on different soybean cultivars .....	47
<b>Table 2.4.</b> Symptoms induced by SMV strains on different soybean cultivars .....	47
<b>Table 3.1.</b> Inoculation treatments.....	85
<b>Table 3.2.</b> Analysis of accumulation of AMV-JD and SMV-N in single- or double-inoculated ‘Williams 82’ .....	86
<b>Table 3.3.</b> Analysis of accumulation of AMV isolates and SMV-N in single- or double-inoculated ‘Williams 82’ .....	87
<b>Table 3.4.</b> Analysis of accumulation of AMV isolates and SMV-G7 in single- or double-inoculated ‘Williams 82’ .....	88
<b>Table 3.5.</b> Analysis of accumulation of AMV isolates and SMV-N in single- or double-inoculated ‘Lee 68’ .....	90
<b>Table 3.6.</b> Analysis of accumulation of AMV-S0118 and SMV-N in single- or double-inoculated ‘Lee 68’ and ‘Williams 82’ .....	91

## List of Figures

<b>Figure 2 1. Steps taken for</b> separation of AMV-S0118 from an unknown SMV contaminant.....	49
<b>Figure 2 2.</b> Local lesions induced by AMV strains on <i>Phaseolus vulgaris</i> .....	50
<b>Figure 2 3.</b> Soybean cv. Colfax distinct responses to inoculation with AMV isolates .....	51
<b>Figure 2.4.</b> Evaluation of different preparations of AMV-S0118 for the absence of SMV contaminant by western immunoblotting.....	52
<b>Figure 2.5.</b> Characteristics of purified preparations of AMV isolates .....	53
<b>Figure 2.6.</b> Characteristics of purified preparations of SMV strains .....	54
<b>Figure 3.1.</b> Experimental design of soybean plants cvs. Williams 82 and Lee 68 in single or mixed-inoculation .....	91
<b>Figure 3.2.</b> Phenotypic responses of ‘Williams 82’ trifoliates leaves to inoculation with AMV-JD, and AMV-JD CP accumulation as determined by Ag-IELISA.....	92
<b>Figure 3.3.</b> Phenotypic responses of ‘Williams 82’ to inoculation with SMV-N.....	93
<b>Figure 3.4.</b> Ag-IELISA analysis of accumulation of CP from SMV-N in ‘Williams 82’ trifoliates leaves.....	93
<b>Figure 3.5.</b> Phenotypic differences in response of ‘Williams 82’ to inoculation with AMV-JD and SMV-N using simultaneous or sequential inoculations.....	94
<b>Figure 3.6.</b> Ag-IELISA analysis of accumulation of CP from AMV-JD and SMV-N in ‘Williams 82’ trifoliolate leaves. ....	95
<b>Figure 3.7.</b> Phenotypic differences in responses of ‘Williams 82’ to inoculation with AMV-JD, AMV-JD and SMV-N, and SMV-N.....	96
<b>Figure 3.8.</b> Phenotypic responses of ‘Williams 82’ trifoliates leaves to inoculation with AMV-JD, AMV-JD and SMV-N, and SMV-N.....	97
<b>Figure 3.9.</b> Phenotypic differences in responses of ‘Williams 82’ to inoculation with AMV-S0118, AMV-S0118 and SMV-N and SMV-N .....	98
<b>Figure 3.10.</b> Ag-IELISA analysis of accumulation of CP from AMV-Ch and SMV-N in ‘Williams 82’ leaves .....	99

<b>Figure 3.11.</b> Ag-IELISA analysis of accumulation of CP from AMV-S0118 and SMV-N in ‘Williams 82’ leaves .....	100
<b>Figure 3.12.</b> Phenotypic differences in response of ‘Williams 82’ to inoculation with AMV-JD, AMV-JD and SMV-G7 and SMV-G7 .....	101
<b>Figure 3.13.</b> Phenotypic differences in response of ‘Williams 82’ trifoliates leaves to inoculation with AMV-JD, AMV-JD and SMV-G7 and SMV-G7 .....	101
<b>Figure 3.14.</b> Ag-IELISA analysis of accumulation of CP from AMV-JD and SMV-G7 in ‘Williams 82’ leaves .....	102
<b>Figure 3.15.</b> Ag-IELISA analysis of accumulation of CP from AMV-JD, and SMV-N and SMV-G7 in ‘Williams 82’ leaves.....	103
<b>Figure 3.16.</b> Phenotypic differences in response of ‘Lee 68’ to inoculation with AMV-JD, AMV-JD and SMV-N, and SMV-N.....	104
<b>Figure 3.19.</b> Phenotypic differences in response of ‘Lee 68’ to inoculation with AMV-Ch, AMV- Ch and SMV-N, and SMV-N .....	104
<b>Figure 3.20.</b> Phenotypic differences in response ‘Lee 68’ to inoculation with AMV-Ch, AMV- Ch and SMV-G7, and SMV-G7 .....	105
<b>Figure 3.21.</b> Phenotypic differences in response of ‘Lee 68’ to inoculation with AMV-S0118, AMV-S0118 and SMV-N and SMV-N .....	105
<b>Figure 3.22.</b> Ag-IELISA analysis of accumulation of CP from AMV-JD and SMV-G7 in ‘Lee 68’ plants .....	106
<b>Figure 3.23.</b> Ag-IELISA analysis of accumulation of CP from AMV-Ch and SMV-G7 in ‘Lee 68’ plants.....	107
<b>Figure 3.24.</b> Ag-IELISA analysis of accumulation of CP from AMV-S0118 and SMV-G7 in ‘Lee 68’ plants.....	108

## Chapter I: Introduction

Plant viruses cause significant economic losses to agricultural productivity (24). To date, more than 1,000 plant viruses have been identified, the majority of which have broad host range (9). In nature, viruses are transmitted mechanically, and by nematodes, fungi, and insects. As many viruses have a number of hosts and vectors in common, there are significant chances for plants to become infected by more than one virus under the natural conditions.

### 1.1. Mixed viral infections

In nature, plants are commonly co-infected by more than one virus, where the outcome is a number of different interactions between viruses and host.

One outcome of mixed viral infection is transencapsidation, where the genome of one virus is encapsidated in the coat protein (CP) of another virus. As a result of transencapsidation, a virus may gain transmission by a new means, such as being transmitted mechanically (35, 51), by seed (29), or by a new vector (5, 31, 45). In nature, it has been shown that aphid *Rhopalosiphum padi* transmits *Barley yellow dwarf virus* isolate MAV in dually infected plants with the serologically-unrelated isolate RPV, mainly due to the encapsidation of its genome in the CP of RPV (45).

Another outcome of mixed viral infection is transcomplementation where encoded protein from one virus complements and provide function for another unrelated virus most commonly by complementing the deficient movement function (9). This has been well demonstrated in the case of recombinant plant viruses expressing *Potato virus*

Y (PVY) helper-component proteinase (HC-Pro) in tobacco, where mixed-infection results in enhancement of accumulation of another virus (42, 62). Transcomplementation, however, has been mostly studied under experimental conditions using transgenic plants or via transient gene expression by using viruses as vehicles for gene delivery (30).

In mixed-infection, viruses can also interact in an antagonist manner, where one virus reduces the replication and subsequently the accumulation of another virus (38, 41). However, mixed viral infection resulting in antagonistic interaction has been reported in only a few instances.

Viral synergism is the most common outcome of interactions between two taxonomically unrelated plant viruses when simultaneously infect the same plant (30). For the purpose of this thesis, I have defined synergism as a result of mixed viral infection of two viruses, where the outcome is an enhancement of symptom severity as well as the accumulation of the CP of one of the viruses involved (33).

Another outcome of mixed-infection involves replication of two viruses in the same cell. In this case, the viruses produce their own individual inclusion bodies, but the viruses do not interact directly with each other (41).

## **1.2. Viral interactions in mixed-infection**

### ***A. Antagonistic interactions***

Antagonistic interactions occur in mixed viral infection of plants when one virus suppresses the replication and accumulation of another virus. Based on a decrease in CP accumulation of one of the viruses, only two cases have been reported, (38, 41). The

better studied system is the interaction of *Sweet potato chlorotic stunt virus* (SPCSV, Genus *Crinivirus* ) with *Sweet potato mild mottle virus* (SPMMV, Genus *Ipomovirus*), and the interaction of SPCSV with *Sweet potato feathery mottle virus* (SPFMV, Genus *Potyvirus*) in sweet potato (38). The interaction of either SPMMV or SPFMV with SPCSV resulted in an increase in symptom severity; i.e., a stronger degree of chlorosis, stunting, distortion, and rugosity, and the induction of dark green islands. Furthermore, there was an enhancement in CP accumulation of SPFMV. In contrast, SPCSV CP accumulation was reduced in both cases. This indicates that the outcome was antagonistic for SPCSV, but synergistic for SPMMV and SPFMV.

### ***B. Synergistic interactions***

In 1925, Dickson reported for the first time the occurrence of a mixed viral interaction. (15). The disease was named ‘streak disease of potato’, and was a result of the interaction of potato mosaic and tobacco mosaic viruses. In 1955, the interaction between *Potato virus X* (PVX) and PVY in tobacco plants was further studied. The outcome was an increase in disease symptoms as well as a three to ten fold increase in PVX CP accumulation (46). However, the interaction between PVX and *Alfalfa mosaic virus* (AMV) did not alter virus accumulation or symptom severity (46). Several synergistic interactions have been reported since then, involving more than 69 virus species from different viral families (30). A broad range of plants may participate in these synergistic activities, but most studies have used indicators or transient plants and not crops (30).

Viral synergism may have multiple impacts on the viruses due to the infection of a higher number of cells, and generation of a larger number of particles per cell (23, 46, 70). Viral synergism may also result in breakdown of plant resistance through a different pattern of viral replication or movement (10, 39, 70, 73). Viral synergism enhances symptom severity, affecting several growth parameters such as plant weight and height. This will subsequently result in yield loss and occasionally viral synergism leads to plant death (Table 1.1) (Tables and figures appeared in the appendices) (19, 40). The most studied synergistic interactions with plant viruses involve members of the *Potyviridae* family (1, 6, 28).

### ***Potyviridae family***

In most mixed viral infection involving potyviruses and non-potyviruses, the level of the non-potyviruses is increased three to ten fold while the level of the potyviruses has remained, in majority of the cases, unchanged (2, 8, 20, 42, 46, 54, 62). However, in certain hosts, accumulation of both non-potyvirus as well as the potyvirus have been increased (53, 56). The synergistic interaction between PVX and PVY in tobacco plants has been extensively reported (23, 54, 63). The interaction has been characterized by an increase in symptom severity and up to a ten fold PVX accumulation compared with plants infected with a single virus. The interaction between PVX and PVY in tobacco is considered as a typical model for plant viral synergism. An increase in PVX accumulation is the result of an increase in the number of viral particles per cell, rather than an increase in the number of infected cells (23). This increase is associated with a change in PVX replication due to the presence of PVY (42, 63). It has been suggested

that in the PVX/PVY system, increase in PVX accumulation is a consequence of modification in replication of the virus, as the level of (-) RNA strand is elevated. Change in PVX replication has been observed in mixed-infections with other potyviruses such as *Tobacco vein mottling virus*, *Tobacco etch virus* and *Pepper mottle virus* in tobacco plants (62). Change in mode of replication has not been found in other mixed viral infection involving potyviruses such as in the case of interaction of *Soybean mosaic virus* (SMV, Family *Potyviridae*) with *Bean pod mottle virus* (BPMV, Family *Comoviridae*) or *Cowpea mosaic virus* (CPMV, Family *Comoviridae*) (2); suggesting involvement of a different mechanism for enhancement of non-potyviruses involved. Nevertheless, mixed-infection of SMV with either BPMV or CPMV results in disease synergism in soybean (2, 26, 43, 47, 49, 58).

The interaction between SMV and BPMV has been studied in more detail compared to the interaction between SMV and CPMV. Soybean plants co-infected with SMV and BPMV developed severe symptoms accompanied by a 66 to 80% yield reduction compared with an average reduction of 25% due to the infection of each of the viruses separately (43). However, the extent of the synergistic interaction depended upon the strain of SMV involved (47). Soybean plants infected with SMV and BPMV exhibited distorted foliage, stunting, curvature and brittleness of stem apices, and necrosis. Anjos et al. (2) reported that soybean plants dually infected with not only SMV and BPMV, but also with CPMV had an increase in symptom severity when compared with single infected plants. Increase of titer in synergistic interactions of the non-potyvirus is linked with the HC-Pro cistron of the potyviruses (22, 42, 54). The HC-Pro

of the potyviruses plays a multifunctional role in the life cycle of viruses including genome amplification and systemic movement. Furthermore, HC-Pro is also a strong suppressor of gene silencing (59).

### **1.3. Gene silencing**

Potyviruses with mutations in the central domain of HC-Pro are unable to induce synergism in mixed viral infections (54). Similar mutations also suppress gene silencing ability of HC-Pro (28). This suggests that the two functions of HC-Pro are closely linked (22, 52). Gene silencing is a broad term that describes all related RNA-guided gene regulatory mechanisms, and is usually used to illustrate a mechanism where a gene is not expressed under regular conditions (16). It is a natural defense mechanism in humans, animals and plants, which also acts as an antiviral defense mechanism. During replication, viruses initiate and target, at the same time, gene silencing, which is a natural defense against foreign nucleic acids (66). Gene silencing has been proposed as a natural antiviral plant defense mechanism (66).

The gene silencing pathway against plant viruses can be broken down into 3 steps. First, viruses infect the cells and during replication produce double-stranded (ds) RNA; then, the ribonuclease Dicer processes the dsRNA into fragments of 21-26 nucleotides. Finally, the RNA-induced silencing complex (RISC) binds the small interfering RNAs (siRNAs), finds homologous nucleic acids, and directs messenger RNA degradation. Gene silencing machinery not only moves from cell to cell, but can also generate a

systemic silencing episode throughout the whole plant (36). In addition, this mechanism has the capacity to supply long-term memory within the infected plant.

Many plants, including soybean, have co-evolved with this defense mechanism against viruses (18, 69, 74). Two major lines of evidence support the presence of this mechanism in plants. The first is that virus infection triggers RNA silencing in plants, which respond by targeting the viral RNAs for degradation (16). The plant has the potential to identify and target replicating viral dsRNA. Moreover, they have also been recognized to be involved in different synergistic interactions between diverse unrelated viruses (16). The second and strongest evidence is that several plant viruses encode proteins capable of suppressing gene silencing (16), thereby allowing one of the viruses in mixed viral infection to accumulate at a higher rate (34).

#### **1.4. Viral suppressors of gene silencing**

Since gene silencing is an antiviral reaction in plants, it is not unusual that a number of viruses encode different proteins to inhibit the initiation, maintenance, or propagation of this defense mechanism (64). Viral suppressors of gene silencing are extensively used as a defense strategy by several plant viruses (Table 1.2). Most of the viral suppressor proteins of gene silencing have been recognized as long-distance movement proteins (i.e. enable viruses to move in or out of the phloem) (34). There are two hypotheses on how viral suppressors of gene silencing work (34). The first is that viral suppressors interact with an element of the gene silencing machinery and inactivate it. The second hypothesis is that the suppressor interacts with an element of the

regulatory pathway that controls gene silencing. Each virus produces a different pathway to suppress mRNA degradation. Several viruses suppress gene silencing in all the infected tissues, but there are others that are only able to do it in specific areas (3, 6). Some viral suppressors have an effect on both new and old leaves since they have the capacity to degrade an element required for continuance of gene silencing. Others encode suppressors of gene silencing like HC-Pro, which have the capacity to block synthesis or activation of an element required for silencing, as a result, suppression will be limited to new emerging leaves (66).

***A. HC-Pro cistron of potyviruses as a suppressor of gene silencing***

The HC-Pro of *Potyviridae* family was the first viral suppressor of gene silencing discovered and it has been widely reported to suppress gene silencing (1, 6, 28, 62). HC-Pro not only prevents, but also reverses gene silencing. HC-Pro suppresses gene silencing through degradation of small RNAs, probably in the cytoplasm, since HC-Pro is mainly localized in this fraction of the cell (50). In tobacco and Arabidopsis plants, HC-Pro reduced dsRNA processing by the ribonuclease Dicer; whereas, in transient experiments PVY HC-Pro enhanced the reduction of siRNAs (17, 32).

In soybean, a recombinant BPMV expressing SMV-HC-Pro induced a significant enhancement in symptom severity and accumulation of CP of BPMV (74). The phenotype was similar to double-infection by SMV and BPMV reported by Anjos et al. (2). Thus, synergism between SMV and BPMV was attributed to the suppression of the soybean silencing machinery by SMV HC-Pro cistron (74).

### **1.5. SMV and AMV in soybean**

SMV and AMV infect soybean in nature. SMV is endemic in soybean, and the incidence of AMV in soybean growing areas of the U.S. is on the rise. Both viruses are transmitted by seed and aphids in the field (9). SMV, a single stranded RNA virus with a positive polarity genome, belongs to the genus *Potyvirus*. It is a member of the *Potyviridae* family that is the largest and most economically important plant virus group. Virus particles are flexuous with a genome of 9,588 nucleotides encapsidated by a single CP (27). The genome is expressed as a polyprotein that is processed into eight or nine mature proteins by three virus-encoded proteases (9, 27). Some of the potyviruses encoded proteins have been extensively studied, where HC-Pro is the cistron that plays multifunctional roles in the virus life cycle (59). Isolates of SMV reported from U.S. have been classified into seven strain groups, G1 to G7, based on virulence on two susceptible and six resistant soybean cultivars (11). Strain group G1 is considered the least virulent, whereas G7 is the most virulent and is able to infect all eight soybean genotypes. Depending upon which SMV strain is involved, damage in soybean could be significant as is the case of necrotic Korean isolate of the G2 strain, which is capable of producing severe necrosis in five different cultivars that possess five SMV resistance genes (12). Disease symptoms typically caused by SMV in soybean include stunting, leaf rolling, deformation and mosaic. Necrosis is produced only in some soybean cultivars. SMV can also cause mottling, and is capable of reduction oil content of the seeds, nitrogen fixation, and seed size (48). SMV has been shown to interact with other viruses in the field,

resulting in mixed-infections with increased symptom severity in infected plants (26, 43, 47).

AMV, a tripartite single stranded RNA virus with a positive polarity genome, belongs to the genus *Alfavirus* and is a member of *Bromoviridae* family. Virions are a mixture of bacilliform and spherical particles, which encapsidate the genome of the virus (61). The viral genome is composed of three RNA molecules, however, CP expressed via a subgenomic RNA known as RNA 4 (9). If naked RNA serves as inoculum, then RNA4 is essential for infection. RNAs 1-3 encode for all the proteins essential for the virus life cycle, including replication, movement of the virus within the tissues, transmission by the vectors and particle formation. The virus CP, a key component in formation of the particles, is synthesized via RNA4 also known as sub-genomic RNA or CP gene. Coat protein, similar to any other virus gene product, serves multiple functions for survival of the virus. In addition to particle formation, it is also involved in virus transmission, initiation of replication, virus movement within infected tissues and symptom induction in certain hosts (9).

AMV is a highly variable virus and has a broad host range of over 600 species in 70 plant families (4); its host range includes soybean and other agriculturally valuable crops (37). AMV infection not only reduces seed germination and seedling vigor, but also has a negative impact on yield and quality of production. The most common foliar symptoms associated with AMV infection in soybean are chlorosis, necrosis, leaf malformation and stunting. However, depending upon soybean genotype, environmental conditions and strain of the virus involved, symptoms can either persist or disappear in

the new tissues of infected plants. However, the virus remains present in symptomless plants (9, 55).

### **1.6. Economic importance of soybean**

Soybean, [*Glycine max* (L.) Merrill; Family Fabaceae, Tribe Phaseoleae], is mainly cultivated in Asia, and the Americas. Although soybean originated in Asia, 45% of the world's production area and 32% of production is in the United States; followed by Brazil, Argentina and China (71). In 2007, U.S. soybean crop was valued at \$ 26.9 billion (60). Soybean seed is an important source of proteins and oil for human and animal consumption. Soybean plants are infected by more than 100 pathogens (25), of which about 35 cause reductions in quality and quantity of soybean production. Approximately 111 viruses or strains have the ability to infect soybean under natural or experimental conditions, whereas 46 viruses are known to infect soybeans naturally (57). However, only 21 viruses including, SMV and AMV, are known to naturally infect soybean in U.S. (Table 1.3). In 2002, U.S. soybean yields were reduced by over 760,000 metric tons due to virus infections (72). Yield reduction due to SMV can be as high as 90% in some cultivars (12, 14, 49). SMV is found in all areas where soybean is grown (7). The incidence of AMV in soybean in Wisconsin, between 2002 and 2003, reduced yields by 26 to 31% (37), suggesting that AMV has the potential to reduce soybean yields drastically in the U.S.

Until the year 2000, U.S. soybean was thought to be free of colonizing aphids; therefore, aphid transmission of viruses was limited (13). The recent introduction of

*Aphis glycines*, commonly known as the soybean aphid, in the Midwest regions of the U.S., has increased the incidence of AMV in soybean, and the virus is considered an emerging disease (4). The aphid can be a very efficient vector of SMV (68). In North America, the soybean aphid was first observed in Wisconsin in the summer of 2000. By the end of the same year, the aphid had spread to Illinois, Indiana, Iowa, Kentucky, Michigan, Minnesota, Missouri, Ohio, and West Virginia. To date, the aphid has been reported in more than 20 states across the U.S. and three Canadian provinces (13, 67), and it is believed to have spread into 80% of the soybean production areas in the U.S. (65). In its native eastern Asia, including China, Indonesia, and Japan, the primary host of *A. glycines* is not soybean, but *Rhamnus* spp. Aphids prefer these trees and lay their eggs there in the fall. Aphids only reproduce asexually on soybean, leading to a large colonies (44). The presence of the aphid and AMV and SMV in soybean increases the likelihood of mixed-infection in the field with a potential to affect negatively soybean production.

### **1.7. Research objectives**

The main goal of this research was to evaluate if mixed-infection between SMV and AMV in soybean may lead to a disease synergism. AMV and SMV have the ability to reduce yield production by 30 and 90%, respectively. The increase in soybean aphid populations and its ability to transmit AMV has lead to increase in AMV incidence in soybean-producing regions. Several members of the *Potyviridae* family have been observed in synergistic interactions. Moreover, SMV has been shown to enhance BPMV

and CPMV accumulation in soybean, but synergism between AMV and SMV in soybean has not been reported.

This research had three objectives: 1) to establish mixed-infection between AMV and SMV in soybean and examine the synergistic interaction; 2) to determine if the synergistic interaction between AMV and SMV is viral strain-independent; and 3) to determine if the synergism between AMV and SMV is soybean genotype-independent.

## References cited

1. Anandalakshmi, R., Pruss, G. J., Ge, X., Marathe, R., Mallory, A. C., Smith, T. H., and Vance, V. B. 1998. A viral suppressor of gene silencing in plants. *Proc. Natl. Acad. Sci. USA.* 95:13079-13084.
2. Anjos, J. R., Jarlfors, U., and Ghabrial, S. A. 1992. Soybean Mosaic Potyvirus Enhances the Titer of 2 Comoviruses in Dually Infected Soybean Plants. *Phytopathology* 82:1022-1027.
3. Beclin, C., Berthome, R., Palauqui, J. C., Tepfer, M., and Vaucheret, H. 1998. Infection of tobacco or Arabidopsis plants by CMV counteracts systemic post-transcriptional silencing of nonviral (trans) genes. *Virology* 252:313-317.
4. Bol, J. F. 2003. *Alfalfa mosaic virus*: coat protein-dependent initiation of infection. *Mol. Plant Pathol.* 4:1-8.
5. Briddon, R. W., Pinner, M. S., Stanley, J., and Markham, P. G. 1990. Geminivirus Coat Protein Gene Replacement Alters Insect Specificity. *Virology* 177:85-94.
6. Brigneti, G., Voinnet, O., Li, W. X., Ji, L. H., Ding, S. W., and Baulcombe, D. C. 1998. Viral pathogenicity determinants are suppressors of transgene silencing in *Nicotiana benthamiana*. *Embo J.* 17:6739-6746.
7. Brunt, A. A., Crabtree, K., Dallwitz, M. J., Gibbs, A. J., and Watson, L., eds. 1996. *Viruses of Plants: Descriptions and Lists from the VIDE Database.* CAB INTERNATIONAL, Cambridge, UK.
8. Calvert, L. A., and Ghabrial, S. A. 1983. Enhancement by Soybean Mosaic-Virus of Bean Pod Mottle Virus Titer in Doubly Infected Soybean. *Phytopathology* 73:992-997.
9. Candelier-Harvey, P., and Hull, R. 1993. Cucumber mosaic virus genome is encapsidated in alfalfa mosaic virus coat protein expressed in transgenic tobacco plants. *Transgenic Res.* 2:277-285.
10. Carr, R. J., and Kim, K. S. 1983. Evidence that Bean Golden Mosaic Virus Invades Non-phloem Tissue in Double Infections with Tobacco Mosaic-Virus. *J. Gen. Virol.* 64:2489-2492.

11. Cho, E. K., and Goodman, R. M. 1979. Strains of Soybean Mosaic-Virus - Classification Based on Virulence in Resistant Soybean Cultivars. *Phytopathology* 69:467-470.
12. Cho, E. K., Chung, B. J., and Lee, S. H. 1977. Studies on identification and classification of Soybean mosaic virus disease in Korea II. Etiology of a necrotic disease of *Glycine max*. *Plant Dis. Rep.* 61:313-317.
13. Clark, A. J., and Perry, K. L. 2002. Transmissibility of field isolates of soybean viruses by *Aphis glycines*. *Plant Dis.* 86:1219-1222.
14. Dhingra, K. L., and Chenulu, V. V. 1980. Effect of Soybean mosaic virus on yield and nodulation of soybean cv. Bragg. *Indian Phytopath.* 33:586-590.
15. Dickson, B. T. 1925. Tobacco and tomato mosaic. *Science* 62:398-398.
16. Ding, S. W., Li, H. W., Lu, R., Li, F., and Li, W. X. 2004. RNA silencing: a conserved antiviral immunity of plants and animals. *Virus Res.* 102:109-115.
17. Dunoyer, P., Lecellier, C. H., Parizotto, E. A., Himber, C., and Voinnet, O. 2004. Probing the microRNA and small interfering RNA pathways with virus-encoded suppressors of RNA silencing. *Plant Cell* 16:1235-1250.
18. Furutani, N., Hidaka, S., Kosaka, Y., Shizukawa, Y., and Kanematsu, S. 2006. Coat protein gene-mediated resistance to *Soybean mosaic virus* in transgenic soybean. *Breed. Sci.* 56:119-124.
19. Garcia-Cano, E., Resende, R. O., Fernandez-Munoz, R., and Moriones, E. 2006. Synergistic interaction between *Tomato chlorosis virus* and *Tomato spotted wilt virus* results in breakdown of resistance in tomato. *Phytopathology* 96:1263-1269.
20. Goldberg, K. B., and Brakke, M. K. 1987. Concentration of maize chlorotic mottle virus is increased in mixed infections with maize dwarf mosaic virus, strain B. *Phytopathology* 77:162-167.
21. Golnaragui, A. R., Shahraeen, N., Pourrahim, R., Farzadfar, Sh., and Ghasemi, A. 2004. Occurrence and Relative Incidence of Viruses Infecting Soybeans in Iran. *Plant Dis.* 88:1069-1074.

22. Gonzalez-Jara, P., Atencio, F. A., Martinez-Garcia, B., Barajas, D., Tenllado, F., and Diaz-Ruiz, J. R. 2005. A single amino acid mutation in the *Plum pox virus* helper component-proteinase gene abolishes both synergistic and RNA silencing suppression activities. *Phytopathology* 95:894-901.
23. Goodman, R. M., and Ross, A. F. 1974. Enhancement of potato virus X synthesis in doubly infected tobacco occurs in doubly infected cells. *Virology* 58: 16–24.
24. Hadidi, A., Khetarpal, R. K., and Koganezawa, H. 1998. *Plant Virus Disease Control*. APS Press, St. Paul, MN.
25. Hartman, G. L., Sinclair, J. B., and Rupe, J. C. 1999. *Compendium of soybean diseases*. APS Press, St. Paul, MN.
26. Hobbs, H. A., Hartman, G. L., Wang, Y., Hill, C. B., Bernard, R. L., Pedersen, W. L., and Domier, L. L. 2003. Occurrence of seed coat mottling in soybean plants inoculated with *Bean pod mottle virus* and *Soybean mosaic virus*. *Plant Dis.* 87:1333-1336.
27. Jayaram, C. H., Hill, J. H., and Miller, W. A. 1992. Complete nucleotide sequence of two Soybean mosaic virus strains differentiated by response in soybean containing the Rsv resistance gene. *J. Gen. Virol.* 73:2067-2077.
28. Kasschau, K. D., and Carrington, J. C. 2001. Long-distance movement and replication maintenance functions correlate with silencing suppression activity of potyviral HC-Pro. *Virology* 285:71-81.
29. Kuhn, C. W., and Dawson, W. O. 1973. Multiplication and Pathogenesis of Cowpea Chlorotic Mottle Virus and Southern Bean Mosaic-Virus in Single and Double Infections in Cowpea. *Phytopathology* 63:1380-1385.
30. Latham, J. R., and Wilson, A. K. 2008. Transcomplementation and synergism in plants: implications for viral transgenes? *Mol. Plant Pathol.* 9:85-103.
31. Lecoq, H., Ravelonandro, M., Wipfscheibel, C., Monsion, M., Raccach, B., and Dunez, J. 1993. Aphid Transmission of a Non-Aphid-Transmissible Strain of Zucchini Yellow Mosaic Potyvirus from Transgenic Plants Expressing the Capsid Protein of Plum Pox Potyvirus. *Mol. Plant-Microbe Interact.* 6:403-406.

32. Mallory, A. C., Reinhart, B. J., Bartel, D., Vance, V. B., and Bowman, L. H. 2002. A viral suppressor of RNA silencing differentially regulates the accumulation of short interfering RNAs and micro-RNAs in tobacco. *Proc. Natl. Acad. Sci. USA.* 99:15228-15233.
33. Malysenko, S. I., Kondakova, O. A. , Taliansky, M. E., and Arabekov, J. G. 1989. Plant virus transport function: complementation by helper viruses is non-specific. *J. Gen. Virol.* 70: 2751-2757
34. Marathe, R., Anandalakshmi, R., Smith, T. H., Pruss, G. J., and Vance, V. B. 2000. RNA viruses as inducers, suppressors and targets of post-transcriptional gene silencing. *Plant Mol. Biol.* 43:295-306.
35. Mayo, M., Ryabov, E., Fraser, G., and Taliansky, M. 2000. Mechanical transmission of *Potato leafroll virus*. *J. Gen. Virol.* 81:2791-2795.
36. Mlotshwa, S., Voinnet, O., Mette, M. F., Matzke, M., Vaucheret, H., Ding, S. W., Pruss, G., and Vance, V. B. 2002. RNA silencing and the mobile silencing signal. *Plant Cell* 14:S289-S301.
37. Mueller, E. E., and Grau, C. R. 2007. Seasonal progression, symptom development, and yield effects of *Alfalfa mosaic virus* epidemics on soybean in Wisconsin. *Plant Dis.* 91:266-272.
38. Mukasa, S. B., Rubaihayo, P. R., and Valkonen, J. P. T. 2006. Interactions between a crinivirus, an ipomovirus and a potyvirus in coinfecting sweetpotato plants. *Plant Pathol.* 55:458-467.
39. Murphy, J. F., and Kyle, M. M. 1995. Alleviation of restricted systemic spread of pepper mottle potyvirus in *Capsium annuum* cv. Avelar by coinfection with a cucumovirus. *Phytopathology* 85: 561–566.
40. Murphy, J. F., and Bowen, K. L. 2006. Synergistic disease in pepper caused by the mixed infection of *Cucumber mosaic virus* and *Pepper mottle virus*. *Phytopathology* 96:240-247.
41. Poolpol, P., and Inouye, T. 1986. Enhancement of cucumber mosaic virus multiplication by zucchini yellow mosaic virus in doubly infected cucumber plants. *Ann. Phytopathol. Soc. Japan* 52:22-30.

42. Pruss, G., Ge, X., Shi, X. M., Carrington, J. C., and Vance, V. B. 1997. Plant viral synergism: The potyviral genome encodes a broad-range pathogenicity enhancer that transactivates replication of heterologous viruses. *Plant Cell* 9:859-868.
43. Quiniones, S. S, Dunleavy, J. M., and Fisher, J. W. 1971. Performance of 3 Soybean Varieties Inoculated with Soybean Mosaic Virus and Bean Pod Mottle Virus. *Crop Sci.* 11:662-664.
44. Ragsdale, D. W., Voegtlin, D. J., and O'Neil, R. J. 2004. Soybean aphid biology in North America. *Ann. Entomol. Soci. Am.* 97:204-208.
45. Rochow, W. F. 1970. Barley Yellow Dwarf Virus. Phenotypic Mixing and Vector Specificity. *Science* 167:875-878.
46. Rochow, W. F., and Ross, A. F. 1955. Virus Multiplication in Plants Doubly Infected by Potato Virus-X and Virus-Y. *Virology* 1:10-27.
47. Ross, J. P. 1968. Effect of Single and Double Infections of Soybean mosaic virus and Bean pod mottle viruses on soybean yield and seed characters. *Plant Dis. Rep.* 52:344-348.
48. Ross, J. P. 1969. Effect of Temperature on Development of Soybean Seed Coat Mottling Caused by Soybean Mosaic Virus. *Phytopathology* 59:1047-1050.
49. Ross, J. P. 1969. Effect of Time and Sequence of Inoculation of Soybeans with Soybean Mosaic and Bean Pod Mottle Viruses on Yields and Seed Characters. *Phytopathology* 59:1404-1410.
50. Roth, B. M., Pruss, G. J., and Vance, V. B. 2004. Plant viral suppressors of RNA silencing. *Virus Res.* 102:97-108.
51. Ryabov, E. V., Fraser, G., Mayo, M. A., Barker, H., and Taliansky, M. 2001. Umbravirus gene expression helps *Potato leafroll virus* to invade mesophyll tissues and to be transmitted mechanically between plants. *Virology* 286:363-372.
52. Saenz, P., Salvador, B., Simon-Mateo, C., Kasschau, K. D., Carrington, J. C., and Garcia, J. A. 2002. Host-specific involvement of the HC protein in the long-distance movement of potyviruses. *J. Virol.* 76:1922-1931.

53. Scheets, K. 1998. Maize chlorotic mottle machlomovirus and wheat streak mosaic rymovirus concentrations increase in the synergistic disease corn lethal necrosis *Virology* 242:28-38.
54. Shi, X. M., Miller, H., Verchot, J., Carrington, J. C., and Vance, V. B. 1997. Mutations in the region encoding the central domain of helper component-proteinase (HC-Pro) eliminate potato virus X/potyviral synergism. *Virology* 231:35-42.
55. Spitsin, S., Steplewski, K., Fleysh, N., Belanger, H., Mikheeva, T., Shivprasad, S., Dawson, W., Koprowski, H., and Yusibov, V. 1999. Expression of alfalfa mosaic virus coat protein in tobacco mosaic virus (TMV) deficient in the production of its native coat protein supports long-distance movement of a chimeric TMV. *Proc. Natl. Acad. Sci. USA*. 96:2549-2553.
56. Stenger, D. C., Young, B. A., Qu, F., Morris, T. J., and French, R. 2007. *Wheat streak mosaic virus* lacking helper component-proteinase is competent to produce disease synergism in double infections with *Maize chlorotic mottle virus*. *Phytopathology* 97:1213-1221.
57. Tolin, S. A., and Lacy, G. H. 2004. Viral, bacterial, and phytoplasmal diseases. Pages 765-819 in: *Soybeans: Improvement, Production, and Uses*, H.R Boerma and J. E. Specht, eds. CSSA, SSA, Madison, WI.
58. Tu, J. C., Ford, R. E., and Quiniones, S. S. 1969. Effect of Soybean mosaic virus and/or Bean pod mottle virus Infection on Soybean Nodulation. *Phytopathology* 60:518-523.
59. Urcuqui-Inchima, S., Haenni, A. L., and Bernardi, F. 2001. Potyvirus proteins: a wealth of functions. *Virus Res.* 74:157-175.
60. USDA, United States Department of Agriculture. 2007. National Agricultural Statistics Services. Verified on April 16 2008.
61. Van Regenmortel, M. H. V., Fauquet, C. M., Bishop, D. H. L., Carstens, E. B., Estes, M. K., Lemon, S. M., Maniloff, J., Mayo, M. A., McGeoch, D. J., Pringle, C. R., and Wickner, R. B. 2000. Virus taxonomy: The classification and nomenclature of viruses Page 1167 in: *The seventh report of the international committee on taxonomy of viruses. Virus Taxonomy, VIIth report of the ICTV*. Academic Press, San Diego.

62. Vance, V. B., Berger, P. H., Carrington, J. C., Hunt, A. G., and Shi, X. M. 1995. 5'-Proximal Potyviral Sequences Mediate Potato-Virus-X Potyviral Synergistic Disease in Transgenic Tobacco. *Virology* 206:583-590.
63. Vance, V.B. 1991. Replication of potato virus X RNA is altered in coinfections with potato virus Y. *Virology* 182: 486-494.
64. Vaucheret, H., Beclin, C., and Fagard, M. 2001. Post-transcriptional gene silencing in plants. *J. Cell Sci.* 114:3083-3091.
65. Venette, R. C., and Ragsdale, D. W. 2004. Assessing the invasion by soybean aphid (Homoptera : Aphididae): Where will it end? *Ann. Entomol. Soc. Am.* 97:219-226.
66. Voinnet, O., Pinto, Y. M., and Baulcombe, D. C. 1999. Suppression of gene silencing: A general strategy used by diverse DNA and RNA viruses of plants. *Proc. Natl. Acad. Sci. USA.* 96:14147-14152.
67. Wang, L., Eggenberger, A., Hill, J., and Bogdanove, A. J. 2006. *Pseudomonas syringae* effector *avrB* confers soybean cultivar-specific avirulence on *Soybean mosaic virus* adapted for transgene expression but effector *avrPto* does not. *Mol. Plant-Microbe Interact.* 19:304-312.
68. Wang, R. Y., and Ghabrial, S. A. 2002. Effect of aphid behavior on efficiency of transmission of Soybean mosaic virus by the soybean-colonizing aphid, *Aphis glycines*. *Plant Dis.* 86:1260-1264.
69. Wang, X. Y., Eggenberger, A. L., Nutter, F. W., and Hill, J. H. 2001. Pathogen derived transgenic resistance to soybean mosaic virus in soybean. *Mol. Breed.* 8:119-127.
70. Wang, Y., Lee, K. C., Gaba, V., Wong, S. M., Palukaitis, P., and Gal-On, A. 2004. Breakage of resistance to Cucumber mosaic virus by co-infection with Zucchini yellow mosaic virus: enhancement of CMV accumulation independent of symptom expression. *Arch. Virol.* 149:379-396.
71. Wilcox, J. R. 2004. World Distribution and Trade of Soybean. Pages 1-14 in: *Soybeans: Improvement, Production, and Uses*, H.R Boerma and J. E. Specht, eds. ASA, CSSA, SSA, Madison, WI.

72. Wrather, J. A., Koenning, S. R., and Anderson, T. R. 2003. Effect of diseases on soybean yields in the United States and Ontario (1999-2002). Online. Plant Health Progress. Published online.
73. Yelina, N. E., Savenkov, E. I., Solovyev, A. G., Morozov, S. Y., and Valkonen, J. P. T. 2002. Long-distance movement, virulence, and RNA silencing suppression controlled by a single protein in hordei- and potyviruses: Complementary functions between virus families. *J. Virol.* 76:12981-12991.
74. Zhang, C. Q., and Ghabrial, S. A. 2006. Development of *Bean pod mottle virus*-based vectors for stable protein expression and sequence-specific virus-induced gene silencing in soybean. *Virology* 344:401-411.

## Appendix: Tables

**Table 1-1.** Viral synergistic interactions in different hosts and the resultant synergistic effects (30)

<i>Virus species</i>	<i>Host</i>	<i>Synergistic Effects</i>
<i>Tomato chlorosis virus</i> + <i>Tomato spotted virus</i>	Tomato	Breaks plant resistance
<i>Cauliflower mosaic virus</i> + <i>Turnip vein clearing virus</i>	Turnip	Symptom enhancement
<i>Potato virus X</i> + <i>Potato virus Y</i>	<i>N. tabacum</i> <i>N. benthamiana</i>	Symptom enhancement Higher RNA accumulation of PVX
<i>Potato virus X</i> + <i>Tobacco vein mottle virus</i>	Transgenic tobacco	Symptom enhancement Higher PVX replication
<i>Potato virus X</i> + <i>Tobacco etch virus</i>	Transgenic tobacco	Symptom enhancement Increased PVX replication
<i>Potato virus X</i> + <i>Pepper mottle virus</i>	Transgenic tobacco	Symptom enhancement Increased PVX replication
<i>Tobacco mosaic virus</i> + <i>Tobacco etch virus</i>	Transgenic tobacco	Increased TMV genomic RNA accumulation Plant death
<i>Potato virus X</i> + <i>Plum pox virus</i>	Transgenic tobacco	Leaf necrosis Plant death
<i>Cucumber mosaic virus</i> + <i>Abutilon mosaic virus</i>	<i>N. benthamiana</i> Tobacco Tomato	Increased AbMV accumulation AbMV plant phloem movement limitation broken
<i>African cassava mosaic virus</i> + <i>East african cassava mosaic cameroon virus</i>	Cassava Tobacco	Symptom enhancement Increased viral DNA accumulation

**Table 1.1.** Continued.

<i>Virus species</i>	<i>Host</i>	<i>Synergism Effects</i>
<i>Cucumber mosaic virus</i> + <i>Potato virus Y</i>	<i>N. tabacum</i>	Increased CMV accumulation Enhancement of PVY movement inside the plant
<i>Cowpea mosaic virus</i> + <i>Soybean mosaic virus</i>	Soybean	Symptom enhancement Increased yield reduction Increased seed coat mottling Increased dependent CP accumulation
<i>Bean pod mottle virus</i> + <i>Soybean mosaic virus</i>	Soybean	Symptom enhancement Increased yield reduction Reduced nodule formation Increased seed coat mottling Increased dependent CP accumulation
<i>Sweet potato chlorotic stunt virus</i> + <i>Sweet potato feathery mottle virus</i>	Sweet potato	Severe mosaic Chlorosis Stunting Leaf reduction and deformation Yield reduction
<i>Sweet potato chlorotic stunt virus</i> + <i>Sweet potato feathery mottle virus</i> + <i>Sweet potato mild speckling virus</i>	Sweet potato	Severe mosaic Chlorosis Stunting Leaf reduction and deformation Yield reduction
<i>Sweet potato chlorotic stunt virus</i> + <i>Sweet potato mild mottle virus</i>	Sweet potato	Severe mosaic Chlorosis Stunting Leaf reduction and deformation Yield reduction

**Table 1-2.** Gene products from a number of plants viruses are capable of suppressing gene silencing (50)

<i>Virus Genus</i>	<i>Virus species</i>	<i>Suppressor</i>
Carmovirus	<i>Turnip crinkle virus</i>	Coat protein
Closterovirus	<i>Beet yellows virus</i>	p21 protein
	<i>Beet yellow stunt virus</i>	p22 protein
Cucumovirus	<i>Cucumber mosaic virus</i>	2b protein
	<i>Tomato aspermy virus</i>	2b protein
Furovirus	<i>Beet necrotic yellow vein virus</i>	P14 protein
Geminivirus	<i>African cassava mosaic virus</i>	AC2 protein
	<i>Tomato yellow leaf curl virus</i>	C2 protein
Hordeivirus	<i>Barley stripe mosaic virus</i>	Γb protein
	<i>Poa semilatent virus</i>	Γb protein
Pecluvirus	<i>Peanut clump virus</i>	P15 protein
Polerovirus	<i>Beet western yellows virus</i>	PO protein
	<i>Cucurbit aphid-borne yellows virus</i>	PO protein
Potexvirus	<i>Potato virus X</i>	p25 protein
Potyvirus	<i>Potato virus Y</i>	HC-Pro
	<i>Tobacco etch virus</i>	HC-Pro
Sobemovirus	<i>Rice yellow mottle virus</i>	P1 protein
Tenuivirus	<i>Rice hoja blanca virus</i>	NS3 protein
Tombusvirus	<i>Tomato bushy stunt virus</i>	P19 protein
	<i>Cymbidium ringspot virus</i>	P19 protein
Tospovirus	<i>Tomato spotted wilt virus</i>	NSs protein

**Table 1-3.** Viruses that naturally infect soybean in U.S. (13)

<i>Family/Genus</i>	<i>Virus species</i>
<i>Bromoviridae</i>	<i>Alfalfa mosaic virus</i> <i>Cowpea chlorotic mottle virus</i> <i>Cucumber mosaic virus</i> <i>Tobacco streak virus</i>
<i>Bunyaviridae</i>	<i>Tomato spotted wilt virus</i>
<i>Caulimoviridae</i>	<i>Soybean chlorotic mottle virus</i>
<i>Comoviridae</i>	<i>Bean pod mottle virus</i> <i>Tobacco ringspot virus</i> <i>Tomato ringspot virus</i>
<i>Geminiviridae</i>	<i>Mungbean yellow mosaic virus</i> <i>Soybean crinkle leaf virus</i>
<i>Luteoviridae</i>	<i>Soybean dwarf virus</i>
<i>Potyviridae</i>	<i>Bean common mosaic virus</i> <i>Bean yellow mosaic virus</i> <i>Blackeye cowpea mosaic virus</i> <i>Peanut mottle virus</i> <i>Peanut stunt virus</i> <i>Peanut strip virus</i> <i>Soybean mosaic virus</i>
<i>Tobamovirus</i>	<i>Tobacco mosaic virus</i>
<i>Umbravirus</i>	<i>Pea enation mosaic virus</i>

## **Chapter II**

**Properties of selected strains of *Alfalfa mosaic virus* and**

***Soybean mosaic virus* from soybean**

## **Abstract**

Soybean is affected by several viruses, including *Alfalfa mosaic virus* (AMV) and *Soybean mosaic virus* (SMV). AMV is a variable virus and strains of the virus induce symptoms in soybeans that are not correlated with serological properties or genomic sequences. Symptoms are influenced by soybean genotypes, environmental conditions, and virus strains. In this study, AMV strains from different geographical regions of the United States were obtained and biologically characterized. Biological clones of eleven AMV isolates were obtained by local lesion transfer and were biologically characterized following mechanically inoculation to different soybean cultivars. The phenotypes of AMV isolates varied on different soybean genotypes. One common feature AMV isolates was symptom remission, where severe symptoms were apparent in the lower trifoliates, but the remainder aerial part the plants were symptomless. AMV isolates Joe Davis, (JD) and Champaign (Ch) (from Illinois) and S0118 (from Virginia), were selected for further experiments based on the symptoms that they induced on 'Williams 82' and 'Lee 68'. AMV-JD induced severe symptoms, while AMV-Ch and AMV-S0118 were mild. The purified virions of each of the isolates were obtained and characterized.

SMV strains G7 and N, each derived from the molecular cloned viruses were selected and their biological properties were analyzed on distinct soybean genotypes. SMV-N is an isolate of strain G2 that induces distinct symptoms in the upper trifoliates of infected Williams 82 and Lee 68, whereas SMV-G7 is a mild isolate and induces mild symptoms on both the soybean cultivars. Both SMV-N and SMV-G7 were purified and characterized.

## 2.1. Introduction

Soybean is considered the most economically important legume crop in the United States and is an essential resource of oil and protein worldwide (1). Soybean is affected by several viruses that reduce soybean yield and quality (23).

*Alfalfa mosaic virus* (AMV), a tripartite single stranded RNA virus with a positive polarity genome, belongs to the genus *Alfavirus* and is a member of *Bromoviridae* family (22). The virions are a mixture of bacilliform and spherical particles, which encapsidate the virus genome and a sub-genomic RNA. The viral genome is composed of three RNA molecules (1). Biologically, AMV is highly variable and has a wide host range of over 600 species in 70 plant families (2). AMV infection reduces soybean seed, germination and seedling vigor, and negatively impacts yield quantity and quality. The most common symptoms associated with AMV infection in soybean are chlorosis, necrosis, leaf malformation, and stunting. However, depending upon soybean genotypes, environmental conditions, and strains of the virus involved, symptoms can either persist or disappear soon after infection. The virus remains present in the symptomless plants (12, 21).

*Soybean mosaic virus* (SMV), a single stranded RNA virus with a positive polarity genome, belongs to the genus *Potyvirus* and is a member of the *Potyviridae* family (22). SMV belongs to the largest and economically most important plant viral groups (10). The virus particles are flexuous with a genome of approximately 9,588 nucleotides, encapsidated by a single protein known as coat protein (CP). The genome is expressed as a polyprotein, which is processed into eight or nine mature proteins by three virus-encoded proteases (12, 15). SMV is an endemic virus in soybean and is present in

most areas where soybean is grown (5, 19). SMV in soybean induces stunting, leaf rolling, mosaic, plant deformation, and depending on the cultivar and virus strain involved even necrosis. It can also cause seed mottling, reduction in oil content, nitrogen fixation, and seed size (18). Yield reduction due to SMV can be as high as 90% in some cultivars (5, 6, 19). Isolates of SMV characterized in the U.S. have been classified based on virulence on two susceptible and six resistant soybean cultivars, into seven strain groups (4), G1 to G7. G1 was considered the least virulent strain group, while G7 was the most virulent capable of infecting all eight soybean genotypes tested.

## **2.2. Materials and methods**

### ***A. Soybean genotypes, virus inoculation and propagation***

Soybean cvs. Colfax, IA 2021, Lee 68, Williams 82 and 5002T; and lines P1 96983, PI153, were used for characterization and propagation of SMV or AMV strains used in this study. Virus free seeds of soybean cultivars ‘Colfax’, ‘IA 2021’, and ‘5002T’ as well as seeds from line ‘PI153’ were obtained from Dr C. Grau (University of Wisconsin, Madison); while seeds from cultivars ‘Williams 82’, ‘Williams’, and lines ‘L78-379’ and ‘PI 96983’ were obtained from the seed collection of the Plant Virology Laboratory – The University of Tennessee.

Plants were grown in a temperature-controlled growth chamber (Percival Scientific. Inc., Perry, IA) at 25°C with a photoperiod of 16 h. Inoculation of soybean plants was conducted mechanically by rubbing carborundum (600 mesh)-dusted fully expanded unifoliate leaves. The inoculum was extracted by grinding young leaves of

infected soybean plants with sterilized cold pestles and mortars at a 1:10 (wt/vol) dilution ratio. The buffers used were chilled (4 °C) 0.1 M and 0.01 M phosphate buffer at pH 7.1 for SMV and AMV, respectively.

## ***B. Viruses***

### ***1. Selection of AMV strains***

The AMV isolates used in this study were kindly provided by different contributors in the U.S. as dried or fresh leaf tissues (Table 2.1). Most of the isolates were from field grown infected soybean plants collected from different geographical regions of the U.S. Each isolate was recovered by mechanical inoculation of sap to unifoliolate leaves of Soybean cv. Colfax.

### **Biological purification of AMV isolates**

Bean (*Phaseolus vulgaris* cvs. Rome and Blue Lake) and cowpea (*Vigna unguiculata* cv. Blackeye and Pinkeye) were used as local lesion hosts in all experiments. These cultivars produced local lesions in response to infection with the eleven AMV isolates. The initial inoculum was sap extracted from infected leaves of ‘Colfax’ soybean maintained in growth chambers. Bean and cowpea unifoliolate leaf surfaces were dusted with carborundum and mechanically inoculated with the infectious sap. AMV lesions were counted three to four days after inoculation and used as inoculum (one necrotic lesion/50 µl buffer) for induction of additional necrotic lesions on the same local lesion host. This practice was done three and six times and finally sap from a lesion served as inoculum and mechanically inoculated to unifoliolate leaves of soybean cv. Colfax .The

presence of AMV in the inoculated plants was confirmed phenotypically as well as by antigen coated indirect enzyme linked immunosorbent assay (Ag-ELISA). The antiserum against AMV-coat protein (CP) was used at a dilution of 1:1000. The infected plants were also tested by the same immuno-assay, but using antiserum against SMV-CP that was used with a similar dilution. Both the antisera were obtained from a collection held at the Plant Virology Laboratory – The University of Tennessee.

### **Storage of AMV isolates**

Biological clones of AMV isolates were propagated in soybean cv. Colfax. The isolates were stored under two different conditions. The systemically infected soybean leaf tissues were either dehydrated with calcium chloride and stored at 4°C or frozen directly in liquid nitrogen and kept at -80°C (10).

### **Separation of AMV-S0118 from mixed-infection with a SMV contaminant**

Soybean cv. Colfax inoculated with infectious sap extract from the original tissues containing AMV-S0118 showed severe symptoms including severe necrosis and leaf desiccation. Examination of sap from these tissues by Ag-IELISA revealed the presence of both AMV and SMV. The AMV-S0118 was separated from the SMV contaminant by biological purification (Fig.2.1). Unifoliate leaves of soybean line L78-379 were dusted with carborundum and mechanically inoculated with the infectious sap containing the two viruses. A sap extract from the second passage in 'L78-379' was inoculated to soybean cv. Colfax and tested with antisera against CPs of both SMV and AMV by Ag-IELISA 14 days post-inoculation (dpi). Inoculum from these soybeans cv. Colfax plants

were used as a source for the generation of biological clones of AMV-S0118 by serial local lesion transfers on bean cv. Top Crop. Eventually, necrotic lesions were used for the propagation of the isolate in soybean cv. Colfax plants, and the virus was physically purified from systemically and mechanically infected leaves 13 dpi. The purity of virus preparation was analyzed spectrophotometrically and by sodium dodecyl sulfate polyacrylamide gel electrophoresis (SDS-PAGE), using specific polyclonal antisera against AMV and SMV CPs as described above.

## ***2. Selection of SMV strains***

Soybean tissues containing progeny derived from molecular clones of SMV strains G7 (9) and N (26) were obtained from the University of Tennessee-Virology Lab and served as source for the two viruses.

## ***C. Antigen Coated Indirect Enzyme Linked Immunosorbent Assay***

Ag-IELISA was used for monitoring the accumulation of CPs of SMV and AMV according to Jaegle and Van Regenmortel (13) with minor changes. Antibodies against AMV and SMV CP, and alkaline phosphatase conjugated goat anti-rabbit IgG (Sigma-Aldrich, St. Louis, MO, USA) were diluted in Tween 20- Phosphate buffered saline (TPBS) at pH 7.4 (1L phosphate buffered saline + 0.5% Tween 20) + 5% non-fat dry milk. ELISA was performed in polystyrene plates (Fisher Scientific, Pittsburgh, PA, USA), which were washed three times with TPBS after each step. Leaf tissues were extracted in phosphate buffered saline (PBS) pH 7.4 at a dilution of 1:10 (wt/vol), and the extract was added to the appropriate wells. The plate was incubated for 1 h at 37°C. After adding 200 µl of blocking solution (PBS + 5% non-fat dry milk) to each well, the plate

was incubated overnight at 4°C. Either anti-AMV or anti-SMV polyclonal antibodies were added to each well in a dilution 1:1000. Following incubation for 1 h at 37°C, alkaline phosphatase conjugated goat anti-rabbit IgG antibodies were diluted (0.6 µl/ml) and added to the wells. Plates were incubated for 1 h at 37°C and diethanolamide substrate buffer (800 ml H<sub>2</sub>O + 97 ml diethanolamide) at pH 9.8 was stirred with a p-nitrophenyl phosphate tablet (Sigma) at a dilution of 0.5 mg/ml and added to the plate. Absorbance of each reaction, at 405 nm, was monitored in a Bio-Rad ELISA reader Model 680 (Bio-Rad Laboratories, California, CA, USA).

#### ***D. Viral purification***

##### ***1. AMV purification***

The AMV isolates used in these experiments were AMV-Joe Davis (JD), AMV-Champaign (Ch) and AMV-S0118 (described in Table 2.3). Isolates were purified according to Hajimorad and Francki (8) and Van Vloten-Doting and Jaspars (25), with minor modifications. All the purification steps were done at 4°C and all the AMV isolates were propagated in soybean cv. Colfax and systemically infected leaf tissues were harvested 10 to 13 dpi. Leaves with pronounced symptoms were ground in 0.1 M K<sub>2</sub>HPO<sub>4</sub>, 0.1 M ascorbic acid and 0.02 M ethyl diamine tetrachloroacetic acid (EDTA) adjusted to pH 7.1 (3 ml/g leaf tissue). The slurry was filtered through cheesecloth and emulsified with a 1:1 (v/v) mixture of chloroform and n-butanol for 1 min (0.4 ml/g leaf tissue). The emulsion was centrifuged in a Sorvall RC-5B refrigerated super speed centrifuge for 10 min at 16,300 g (FiberLite Rotor F14-6x 250y) and the aqueous layer was recovered. After addition of polyethylene glycol (PEG, M.W. 6000) (Sigma) to 1.5%

(w/v), the mixture was stirred for 1 h and then centrifuged at 69,000 g for 3 h in a Beckman Le-80 Ultracentrifuge (Beckman Rotor type 42.1) at 4°C. The pellet was suspended overnight at 4°C in 10 mM phosphate buffer, pH 7.0, containing 2% Triton X-100. The suspension was centrifuged for 10 min at 12,000 g (FiberLite Rotor F215-8x50y). Supernatant was recovered and centrifuged for 3 h at 69,000 g. Pelleted viral particles were suspended in 10 mM phosphate buffer, pH 7.0, containing 2% Triton X-100 and centrifuged for 10 min at 12,000 g. Supernatant was recovered and centrifuged over a 1/10 volume of sucrose cushion 10% (w/v) in 10 mM phosphate buffer, pH 7.0, containing 2% Triton X-100 for 1.5 h at 388,000 g (Beckman Rotor type 70.1). Supernatant was discarded, and the pellet was rinsed and resuspended in 10 mM phosphate buffer at pH 7. The solution was centrifuged for 10 min at 12,000 g, and the supernatant recovered. Absorption spectrum was obtained (UV 16000, Shimadzu), and the virus concentration was determined using an extinction coefficient of 5 at 260 nm (25). After the addition of 50% glycerol to the final volume, virus was stored at -20°C.

## ***2. SMV purification***

SMV was purified according to Hajimorad and Hill (8), and Hill and Benner (10) with minor changes. All the purification steps were performed at 4°C and soybean cv. Colfax and 'Williams' were used for propagation of SMV-N and SMV-G7, respectively. The systemically infected leaf tissues were harvested at 14 to 21 dpi. Leaves with obvious symptoms were ground in 100 mM sodium phosphate, 2 mM EDTA, and 1% sodium sulfite adjusted to pH 7.5 (3 ml/g leaf tissue). Slurry was filtered through cheesecloth and centrifuged at 16,300 g for 15 min. Supernatant was recovered, and

filtered again through cheesecloth and subsequently stirred in the presence of 8 % (v/v) n-butanol for approximately 2 h at 4°C. Then it was incubated for 1 h without stirring. After addition of PEG (M.W. 6000) at 2% (w/v), the mixture was stirred for 2 h and incubated overnight without stirring. The preparation was then centrifuged at 16,300 g for 30 min. The resulting pellet was resuspended in 10-20 ml of 10 mM sodium phosphate buffer pH 7.5, 1% sodium sulfite, stirred for 30 min and centrifuged at 12,000 g for 10 min. Supernatant was recovered and centrifuged on 1/10 volume of sucrose cushion 30% (w/v) in 10 mM sodium phosphate buffer pH 7.5, 1% sodium sulfite for 3 h at 93,000 g (Beckman Rotor type 42.1). Supernatant was discarded, and the pellet was resuspended in 10 mM sodium phosphate buffer pH 7.5. Cesium chloride was added to final concentration of 50% (w/v), and solution was centrifuged for 18 h at 148,900 at 15°C (Beckman Rotor SW55Ti). The tubes were analyzed for light scattering, the virus band was recovered, and cesium chloride was removed by dialysis against 0.05 M Na Borate buffer pH 7.0. Absorption spectrum was obtained as described above, and virus concentration was determined spectrophotometrically by using extinction coefficient of 2.4 at 260 nm (11). The virus preparation was stored at -20°C.

#### ***E. SDS-polyacrylamide gel electrophoresis***

Relative levels of AMV and SMV coat proteins in purified virus preparations and in infected tissues were monitored according to the methods described by Sambrook and Russell (20) with minor changes. Slab minigels (Mini-PROTEAN II dual slab cell apparatus, Bio-Rad) were used for electrophoresis. Each sample was fractionated by SDS-PAGE on a 12% slab gel using SDS-discontinuous Laemmli buffer system (16).The

12% acrylamide solution was poured into the space between the glass plates and maintained at 37°C for 1 h for polymerization. The upper stacking gel solution was poured onto the surface of the lower polymerized gel and maintained at 37°C for 30 min for polymerization. The cassette was mounted into an electrophoresis apparatus and tris-glycine electrophoresis buffer pH 8.3 was added to the apparatus. Tissues collected from systemically infected plants were ground in liquid nitrogen and mixed with five volumes of extracting buffer (10% glycerol, 50 mM Tris-HCl, pH 6.8, 5% 2-mercaptoethanol and 2% SDS). Homogenized samples were then boiled for 5 min in a 1:1 mixture of the ground sample plus SDS-PAGE loading buffer (62.5 mM Tris-HCl pH 6.8 containing 5% 2-mercaptoethanol, 10% glycerol and 0.01% of bromophenol blue) and clarified by centrifugation at 10,000 rpm for 10 min. Purified virus suspension was mixed 1:1 (v/v) with SDS-PAGE loading buffer and boiled for 5 min. Subsequently, 20 µl of each sample was loaded into the wells, and electrophoresis was done at 120 V. After that, voltage was increased to 180 V, until the bromophenol blue reached the bottom of the gel. The gels were stained with coomassie brilliant blue. To make a permanent record, stained gels were photographed using a White Light Transilluminator Universal Hood from Bio-Rad Laboratories.

#### ***F. Western immuno-blotting***

Western immuno-blotting was performed according to the method described by Sambrook and Russell (20) with minor changes. Antibodies against AMV, SMV as well as alkaline phosphatase conjugated goat anti-rabbit IgG were diluted in Tween- Tris buffered saline (TTBS) pH 7.4 (1L tris buffered saline + 0.5% Tween) + 5% non-fat dry

milk. The membranes were washed several times with TTBS after each step. Fractionated proteins by SDS-PAGE were transferred electrophoretically to nitrocellulose membranes utilizing a Trans-Blot Electrophoretic Transfer Cell (Bio-Rad) while using transfer buffer (25 mM Tris, 192 mM glycine, 20% methanol, 0.1% SDS, pH 8.3). The membranes were blocked for 2 h in TBS + 5% non-fat dry milk at room temperature with constant stirring. The CP of AMV and SMV were probed with polyclonal antibodies and the membranes were incubated for 1 h at room temperature. The membranes were washed in TTBS. Alkaline phosphatase conjugated goat anti-rabbit IgG antibodies were diluted (0.6 µl/ml), added to the membrane, and incubated for 1 h at room temperature. The reaction was visualized with nitroblue tetrazolium (NBT)/ bromo-4-chloro-3 indolyl phosphate (BCIP) (Promega, Madison, WI, USA) colorimetric AP substrate buffer (0.1 M Tris, 0.1 M NaCl, 5 mM MgCl<sub>2</sub>, pH 9.5).

## **2.3. Results**

### ***A. Viruses***

#### ***1. Selection of AMV isolates***

##### **Generation of biological clones of selected AMV isolates**

Biological clones of selected AMV isolates were obtained by local lesion transfers to different cultivars of bean or cowpea (Table 2.2). This practice eliminated the possibility of mixed-infections. AMV strains induced different pattern of lesions on local lesion hosts (Fig. 2.2)

### **Biological properties**

The AMV isolates were inoculated to different soybean cultivars and biologically characterized. Some of the biological properties of these isolates are presented in Table 2.3 and Fig .2.3.

### **Separation of AMV-S0118 from a SMV contaminant**

Original tissues containing AMV-S0118 also contained an unknown isolate of SMV. Isolate AMV- S0118 was separated from an unknown SMV isolate through both biological and physical methods (Fig. 2.4).

### **Purification and characterization of selected isolates**

It is known that different symptoms induced by AMV isolates do not correlate with serological properties or nucleic acid sequences (14). Symptom expression depended primarily on the soybean cultivars, environmental conditions, and the virus strains. Nevertheless, a common phenotype shared among all the AMV isolates studies was the recovery phenotype (12, 14).

AMV isolates JD, Ch and S0118 were selected for further experiments based on the symptoms that they induced on ‘Williams 82’ and ‘Lee 68’ soybeans. In general, AMV-JD induced severe symptom that was independent of the soybean genotype tested. Symptoms induced by AMV-JD initially consisted of necrosis, mottling, chlorosis, and severe mosaic; however, at a later stage it was associated with a recovery phenotype in soybean cvs. Colfax, Lee 68, and Williams 82. The AMV-Ch induced mosaic, mild

stunting, chlorosis and a recovery phenotype in the same cultivars; whereas, AMV-S0118 induced symptoms similar to AMV-Ch.

Three AMV strains were physically purified, and the virus yields obtained were 30.2 mg for JD, 24.5 mg for Ch and 7.7 mg for S0118. The infectivity of each of the purified virus preparations was tested on bean where each induced uncountable lesions on the inoculated leaves. Purity of the viral preparations was assessed based upon ultraviolet absorption and by SDS-PAGE analysis as described above (Fig. 2.5).

## *2. Selection of SMV strains*

### **Biological properties**

SMV-N and G7 isolates were chosen for further experiments because they each caused unique symptoms on soybean cultivars and belong to different strain groups of SMV (Table 2.4). SMV-N induced severe symptoms. Infected plants of ‘Williams 82’ and ‘Lee 68’ were severely stunted, and leaves were exhibiting severe mosaic and deformation. On the other hand, SMV-G7 induced mild symptoms. The SMV-G7 is considered as a mild isolate. It caused a mild mosaic and mild stunting in ‘Williams 82’. Infected ‘Lee 68’ plants had mild mosaic at the beginning of the infection; however, two weeks post-inoculation plants were symptomless.

### **Purification of SMV-N and SMV-G7 and properties of purified viruses**

The SMV-N and SMV-G7 were purified and the infectivity of the virus preparations were tested through the induction of symptoms on ‘Williams 82’ inoculated plants. A total of 20.6 mg for SMV-N and 2.9 mg for SMV-G7 were obtained. The purity

of the viral preparations was assessed spectrophotometrically and by SDS-PAGE analysis, as described above (Fig. 2.6).

#### **2.4. Discussion**

AMV is a highly variable virus that infects a broad range of plants and is distributed worldwide (24). AMV isolates are antigenically quite similar (8). Nevertheless, the AMV isolates have been phylogenetically classified into four or more groups based on the CP nucleotide sequence (27). AMV is becoming an important viral disease of soybean in the U.S. due to the introduction of the soybean aphid to the soybean growing areas (17).

The AMV isolates used in this study induced different patterns of necrotic lesions on either cowpea or bean leaves. However, lesions were expressed only under defined environmental conditions and were cultivar dependent. In this study AMV isolates induced a broad range of symptoms in soybean, which varied on different soybean cultivars. Symptoms varied from mild chlorosis, to severe mosaic, mottling and stunting. Overall, AMV-JD and AMV-S induced the more severe symptoms in soybean cv. Williams 82 and Colfax, respectively. Furthermore, symptoms varied greatly with environmental conditions, especially light intensity and relative humidity. These results are in agreement with the other reports where it has been shown that soybean cultivars and environmental conditions influence symptom induction by AMV (24). Interestingly, a common phenotype was observed where AMV infected plants exhibited AMV-induced symptoms in the lower trifoliates, but symptom remission in the rest of the plants. However, the virus was detectable in the symptomless tissues and sap from such tissues

produced necrotic lesions on either cowpea or bean leaves. Variation in symptoms among trifoliates also correlated with variations in AMV CP accumulation. AMV symptom remission has not been reported in soybean plants, but is known to occur in tobacco plants (12). In AMV infected tobacco plants, the virus concentration drops, and then rises again in a cyclic manner, similar with what has been observed in soybean plant in this study. However, AMV induced symptom remission is host-dependent since *Chenopodium amaranticolor*-infected plants do not follow this behavior (12).

SMV strains also differ in pathogenicity and symptom expression. SMV strains have been classified into 7 strains (G1-G7) (4); further studies have shown five more strains in Japan (A-E) (22), and six different strains in China (7). However, the pathotypic relationship between these strains have not been established (3).

The SMV strains used in this study, N (an isolate of G2) and G7, induced different patterns of symptoms in soybean plants tested. SMV-G7 induced milder symptoms even though, it is categorized as a more virulent strain than G2 (because it overcomes resistance gene) (4). ‘Williams 82’ and ‘Lee 68’-infected plants with G2 isolate (N) were severely stunted, had severe mosaic, and leaf deformation. However, strong leaf deformation was observed on both trifoliates 3 and 4, which can be used as a phenotypical marker for this isolate. On the other hand, SMV-G7 caused mild mosaic and mild stunting on ‘Williams 82’. Furthermore, SMV-G7 infected ‘Lee 68’ soybean plants became symptomless around two weeks post-inoculation.

## References cited

1. Bol, J. F. 2003. *Alfalfa mosaic virus*: coat protein-dependent initiation of infection. *Mol. Plant Pathol.* 4:1-8.
2. Candelier-Harvey, P., and Hull, R. 1993. Cucumber mosaic virus genome is encapsidated in alfalfa mosaic virus coat protein expressed in transgenic tobacco plants. *Transgenic Res.* 2:277-285.
3. Chen, P., Buss, G. R., and Tolin, S. A. 2004. Reaction of soybean to single and double inoculation with different *Soybean mosaic virus* strains. *Crop Prot.* 23:965-971.
4. Cho, E. K., and Goodman, R. M. 1979. Strains of Soybean Mosaic-Virus - Classification Based on Virulence in Resistant Soybean Cultivars. *Phytopathology* 69:467-470.
5. Cho, E. K., Chung, B. J., and Lee, S. H. 1977. Studies on identification and classification of Soybean mosaic virus disease in Korea II. Etiology of a necrotic disease of *Glycine max*. *Plant Dis. Rep.* 61:313-317.
6. Dhingra, K. L., and Chenulu, V. V. 1980. Effect of Soybean mosaic virus on yield and nodulation of soybean cv. Bragg. *Indian Phytopath.* 33:586-590.
7. Gai, J., Hu, Y. Z., Zhang, Y. D., Xiang, Y. D., and Ma, R. H. 1989. Inheritance of resistance of soybeans to four local strains of Soybean mosaic virus. Pages 1182–118 in: Pascale, A.J., eds. *Proceedings of World Soybean Research Conference IV*, Argentina Soybean Association. Buenos Aires, Argentina.
8. Hajimorad, M. R., and Francki, R. I. B. 1988. Alfalfa Mosaic-Virus Isolates from Lucerne in South-Australia - Biological Variability and Antigenic Similarity. *Ann. Appl. Biol.* 113:45-54.
9. Hajimorad, M. R., Eggenberger, A. L., and Hill, J. H. 2003. Evolution of *Soybean mosaic virus*-G7 molecularly cloned genome in *RsvI*-genotype soybean results in emergence of a mutant capable of evading *RsvI*-mediated recognition. *Virology* 314:497-509.
10. Hill, J. H., and Benner, H. I. 1980. Properties of Soybean Mosaic-Virus and Its Isolated Protein. *J. Phytopathol.* 97:272-281.

11. Hollings, M., and Brunt, A. A. 1981. Potyvirus group. CMI/AAB. Descriptions of Plant Viruses. No.245. CMI/AAB, Kew, Surrey, England.
12. Jaegle, M., and Van Regenmortel, M. H. V. 1985. Use of ELISA for measuring the extent of serological cross-reactivity between plant viruses. J. Virol. Methods 11:189-198.
13. Jaspars, E. M. J., and Bos, L. 1980. Alfalfa mosaic virus. CMI/AAB. Descriptions of Plant Viruses. No.229. CMI/AAB, Kew, Surrey, England.
14. Jayaram, C. H., Hill, J. H., and Miller, W. A. 1992. Complete nucleotide sequence of two Soybean mosaic virus strains differentiated by response in soybean containing the *Rsv* resistance gene. J. Gen. Virol. 73:2067-2077.
15. Laemmli, U. K. 1970. Cleavage of structural proteins during the assembly of the head of bacteriophage T4. Nature 227:680-685.
16. Mueller, E. E., and Grau, C. R. 2007. Seasonal progression, symptom development, and yield effects of *Alfalfa mosaic virus* epidemics on soybean in Wisconsin. Plant Dis. 91:266-272.
17. Ross, J. P. 1969. Effect of Temperature on Development of Soybean Seed Coat Mottling Caused by Soybean Mosaic Virus. Phytopathology 59:1047-1050.
18. Ross, J. P. 1969. Effect of Time and Sequence of Inoculation of Soybeans with Soybean Mosaic and Bean Pod Mottle Viruses on Yields and Seed Characters. Phytopathology 59:1404-1410.
19. Sambrook, J., and Russell, D. W. 2001. Molecular Cloning: A Laboratory Manual. Pages A8 41-A8 45 in: Cold Spring Harbor Laboratory Press, Cold Spring Harbor, N.Y.
20. Spitsin, S., Steplewski, K., Fleysh, N., Belanger, H., Mikheeva, T., Shivprasad, S., Dawson, W., Koprowski, H., and Yusibov, V. 1999. Expression of alfalfa mosaic virus coat protein in tobacco mosaic virus (TMV) deficient in the production of its native coat protein supports long-distance movement of a chimeric TMV. Proc. Natl. Acad. Sci. USA. 96:2549-2553.
21. Takahashi, K. , Tanaka, T. , Iida, W., and Tsuda, Y. 1980. Studies on virus diseases and causal viruses of soybean in Japan. Bull. Tohoku Nat. Agric. Exp. Stn. 62:1-130.

22. Tolin, S. A., and Lacy, G. H. 2004. Viral, bacterial, and phytoplasmal diseases. Pages 765-819 in: Boerma, H. R., and J. E. Specht (eds.) Soybeans: Improvement, production, and uses. American Society of Agronomy, Inc., Madison, Wisconsin.
23. USDA, United States Department of Agriculture. 2007. National Agricultural Statistics Services. Verified on April 16 2008.
24. Van Regenmortel, M. H. V., Fauquet, C. M., Bishop, D. H. L., Carstens, E. B., Estes, M. K., Lemon, S. M., Maniloff, J., Mayo, M. A., McGeoch, D. J., Pringle, C. R., and Wickner, R. B. 2000. Virus taxonomy: The classification and nomenclature of viruses Page 1167 in: The seventh report of the international committee on taxonomy of viruses. Virus Taxonomy, VIIth report of the ICTV. Academic Press, San Diego.
25. Vanvlote.L, and Jaspars, E. M. J. 1972. Uncoating of Alfalfa Mosaic Virus by Its Own RNA. Virology 48:699-708.
26. Wang, L., Eggenberger, A., Hill, J., and Bogdanove, A. J. 2006. *Pseudomonas syringae* effector *avrB* confers soybean cultivar-specific avirulence on *Soybean mosaic virus* adapted for transgene expression but effector *avr Pto* does not. Mol. Plant-Microbe Interact. 19:304-312.
27. Xu, H., and Nie, J. 2006. Identification, characterization, and molecular detection of *Alfalfa mosaic virus* in potato. Phytopathology 96:1237-1242.

## Appendix 2: Tables

**Table 2-1.** Original hosts, locations and contributors of AMV isolates used in this study

<i>Isolates name</i>	<i>Geographical regions</i>	<i>Contributors</i>
Severe <sup>1</sup>	Unknown	Virology collection-University of Tennessee
91 <sup>1</sup>	Unknown	Virology collection- University of Tennessee
Champaign <sup>2</sup>	Illinois	L. Domier, University of Illinois
Joe Davies <sup>2</sup>	Illinois	L. Domier, University of Illinois
SE-12 <sup>2</sup>	Indiana	K. Perry, Cornell University
AMV-20 <sup>2</sup>	Wisconsin	C. Grau, University of Wisconsin
Ar 11 2006 <sup>2</sup>	Wisconsin	C. Grau, University of Tennessee
K1 <sup>2</sup>	Indiana	K. Perry, Cornell University
0605-109 <sup>2</sup>	Wisconsin	C. Grau, University of Wisconsin
06 Ar 12 <sup>2</sup>	Wisconsin	C. Grau, University of Wisconsin
S01-18 <sup>2</sup>	Virginia	S. Tolin, Virginia Polytechnic Institute & State University

<sup>1</sup> Original host is unknown

<sup>2</sup> Original host is soybean

**Table 2-2.** Local lesion hosts used for generation of biological clones of AMV isolates

	<i>Local lesion hosts</i> <sup>1</sup>				
	<i>Phaseolus</i>	<i>Phaseolus</i>	<i>Phaseolus</i>	<i>Vigna</i>	<i>Vigna</i>
	<i>vulgaris cv.</i>	<i>vulgaris cv.</i>	<i>vulgaris cv.</i>	<i>unquiculata</i>	<i>unquiculata</i>
	<i>Roma</i>	<i>Blue lake</i>	<i>Top crop</i>	<i>cv. Blackeye</i>	<i>cv. Pinkeye</i>
<i>AMV strains</i>					
Severe	+ <sup>2</sup>	+	NT	NT	NT
91	-	+	NT	NT	NT
Champaign	+	+	NT	NT	NT
Joe Davies	-	-	NT	+	+
SE12	-	-	NT	+	-
AMV-20	-	+	NT	NT	NT
Ar112006	-	+	NT	NT	NT
K1	-	+	NT	-	-
0605109	-	+	NT	NT	NT
06Ar12	-	-	NT	-	+
S0118	-	-	+	-	-

<sup>1</sup> Plants were maintained at 22°C with 10 hrs of light /day

<sup>2</sup> Symbols indicate presence (+) or absence (-) of local lesion following mechanical inoculation. NT = Not tested

**Table 2-3.** Symptoms induced by AMV isolates on different soybean cultivars

<i>AMV isolates</i>	<i>Soybean cultivars tested</i>						
	<i>Colfax</i>	<i>IA 2021</i>	<i>Lee 68</i>	<i>PI 153</i>	<i>PI 96983</i>	<i>Williams 82</i>	<i>5002 T</i>
Champaign	Ch	NT	M, N, R	NT	NT	Ch, Mi S, SR UT	NT
Joe Davis	B, C, Ch, E, M, Mo, N	NT	M, R	NT	NT	Ch, Mi S, SR UT	NT
Severe	Ch, M, N, S	+, Ch UT	Ch, M, R	-	Ch, M, N, SR UT	Ch	Ch, N, SR UT
S0118	Ch, M, N	NT	Ch	NT	NT	Ch, Mi S, SR UT	NT
91	Ch, E, N	Ch, S,	Ch, M, S	-	+	+ - LT	Ch, S

Symbols indicate symptoms in systemically infected lower (LT) or upper trifoliates (UT).

Mi = mild; + = symptomless infection; - = not infected; +- = results variable between experiments; B = blistering; C = curling; Ch = chlorosis; E = epinasty; Ld = leaf deformation; M = mosaic severe; Mo = mottling; N = necrosis; SR = symptom remission; S = stunting; Vc = vein chlorosis; NT = not tested.

**Table 2-4.** Symptoms induced by SMV strains on different soybean cultivars

<i>SMV strains</i>	<i>Soybean cultivars tested</i>			
	<i>Colfax</i>	<i>Lee 68</i>	<i>PI 96983</i>	<i>Williams 82</i>
G7	M, N, S	+	Sy Ch , tip N	Mi M, S
N	-	E, Se Ld and Lr UT , M, S	E, Mi M, S	Se Ld and Lr UT, M, Se Mo

Symbols indicate symptoms on systemically upper trifoliates (UT).

Mi = mild; Se = severe; Sy = systemic; + = symptomless infection; - = not infected; Ch = chlorosis; E = epinasty; Ld = leaf deformation; Lr = leaf rolling; M = mosaic severe; Mo = mottling; N= necrosis; S = stunting; NT = not tested.

## Appendix 2: Figures

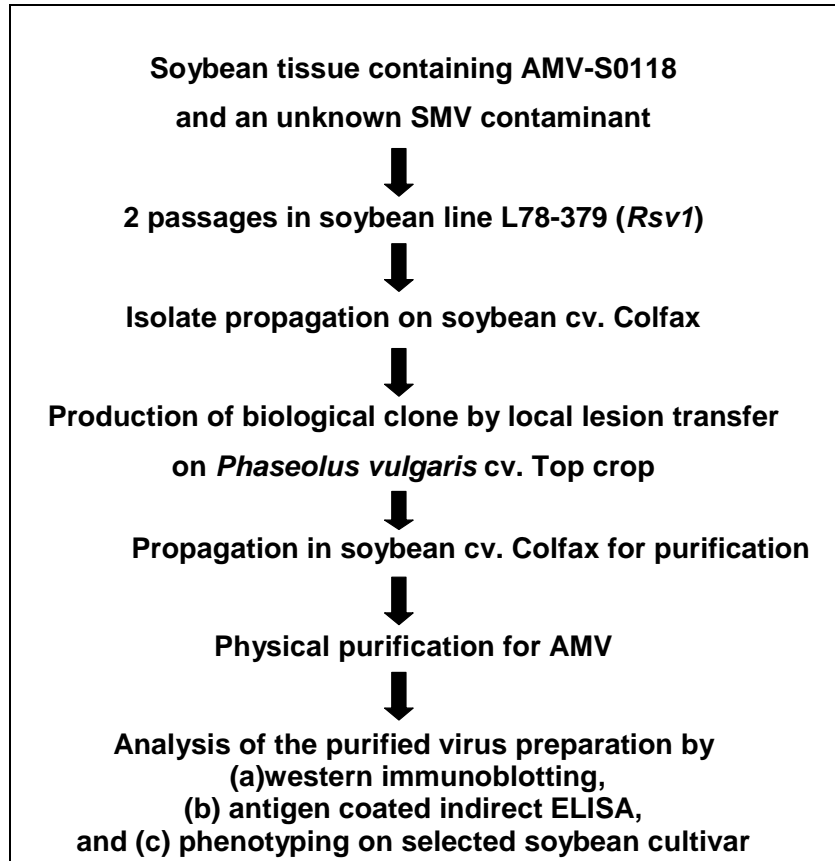

**Figure 2-1.** Separation of AMV-S0118 from an unknown SMV contaminant by biological and physical methods

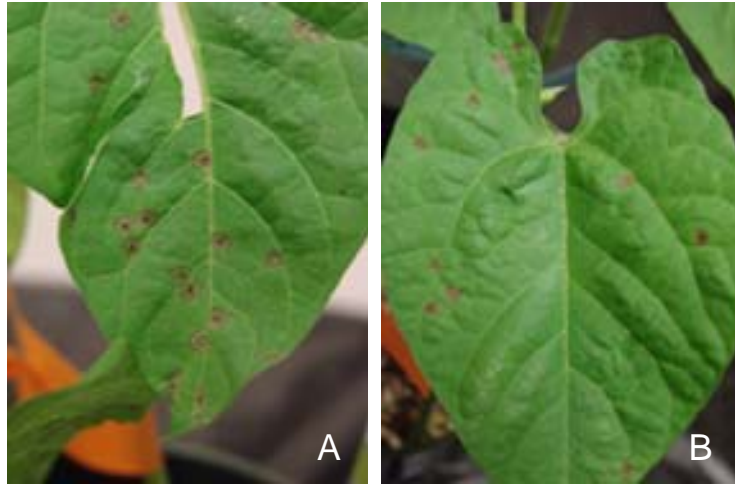

**Figure 2-2.** Local lesions induced by AMV strains 91 (**A**) and S (**B**) on *Phaseolus vulgaris* cv. Blue lake

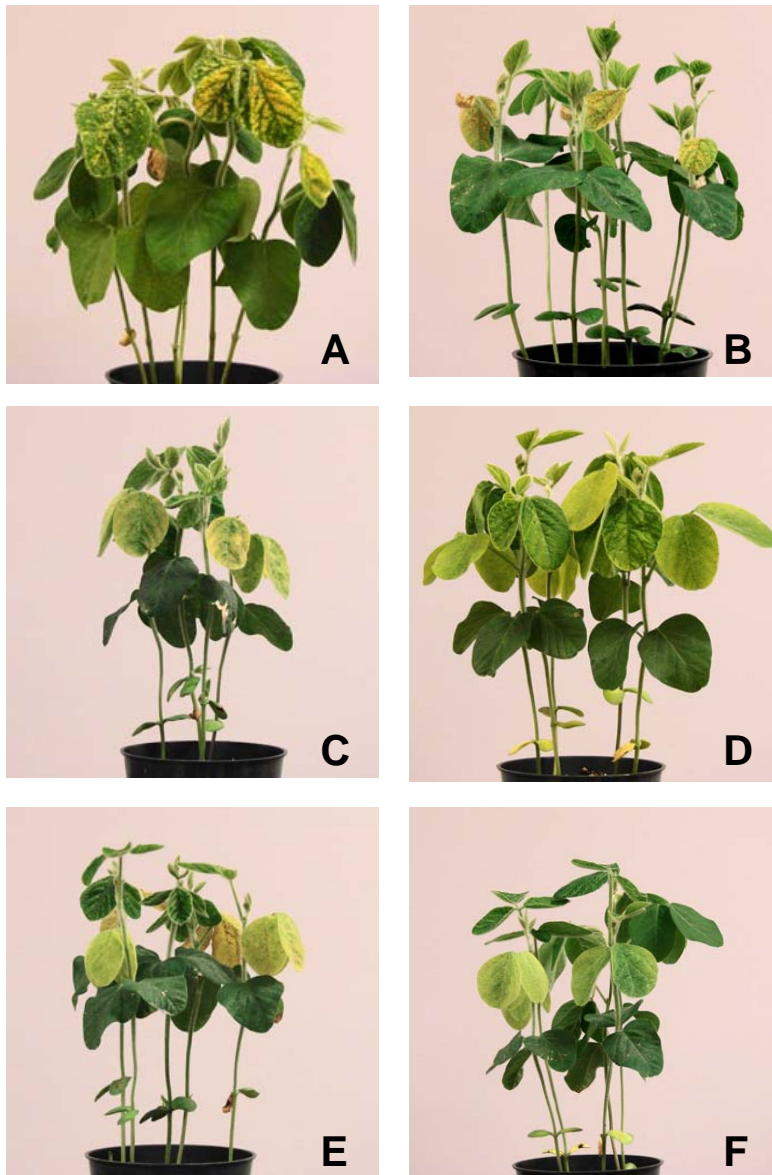

**Figure 2-3.** Soybean cv. Colfax distinct responses to inoculation with infectious sap containing virions of AMV isolates (A) S, (B) Se12, (C) OAr12, (D) 0605148, (E) Ar112006, and (F) 20. Following inoculation, the plants were maintained in a growth chamber (25°C) until photographed about 2 weeks post-inoculation.

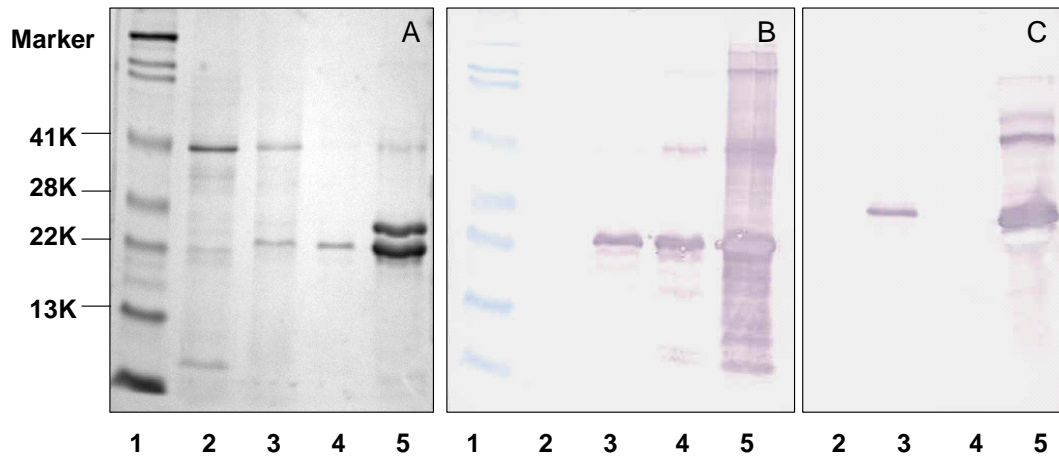

**Figure 2-4.** Evaluation of different preparations of AMV-S0118 for the absence of SMV contaminant by western immuno-blotting. Protein extract from the initially infected soybean tissues containing AMV-S0118 (Lane 3), a purified preparation of AMV-S0118 (Lane 4), and a purified preparation containing both AMV-S0118 and SMV contaminant (Lane 5) were subjected to electrophoresis in three similar 12% polyacrylamide gels. Lane 2 was loaded with protein extract from mock inoculated soybean and molecular markers were loaded in Lane 1. One gel was stained with coomassie brilliant blue (**A**), and two sister gels were transferred to nitrocellulose membranes and probed with polyclonal antisera against AMV CP (**B**) or SMV CP (**C**).

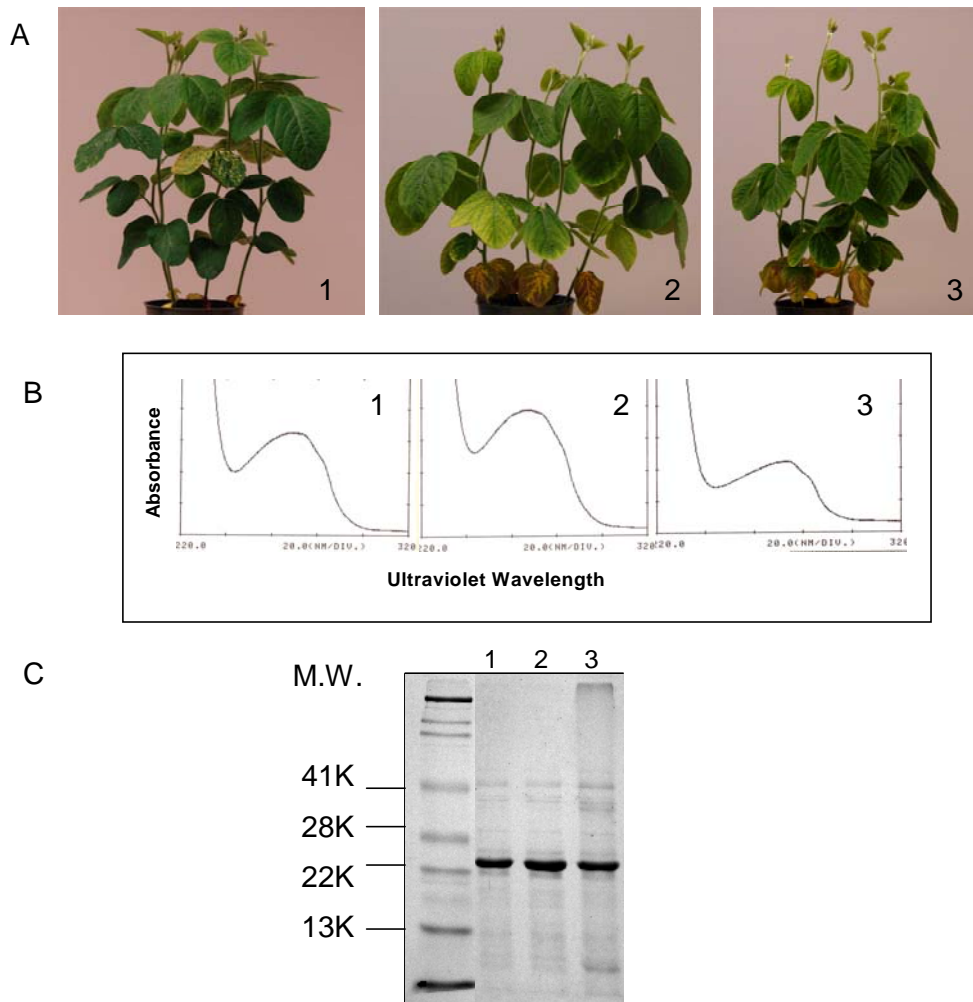

**Figure 2-5.** Characteristics of purified preparations of AMV isolates (1) JD, (2) Ch, and (3) S0118. (A) Phenotypes of AMV isolates on ‘Williams 82’ 21 days post-inoculation, (B) ultraviolet absorbance spectra of purified preparations, and (C) detection of AMV CP by electrophoresis in 12% polyacrylamide gel and stained with coomassie blue.

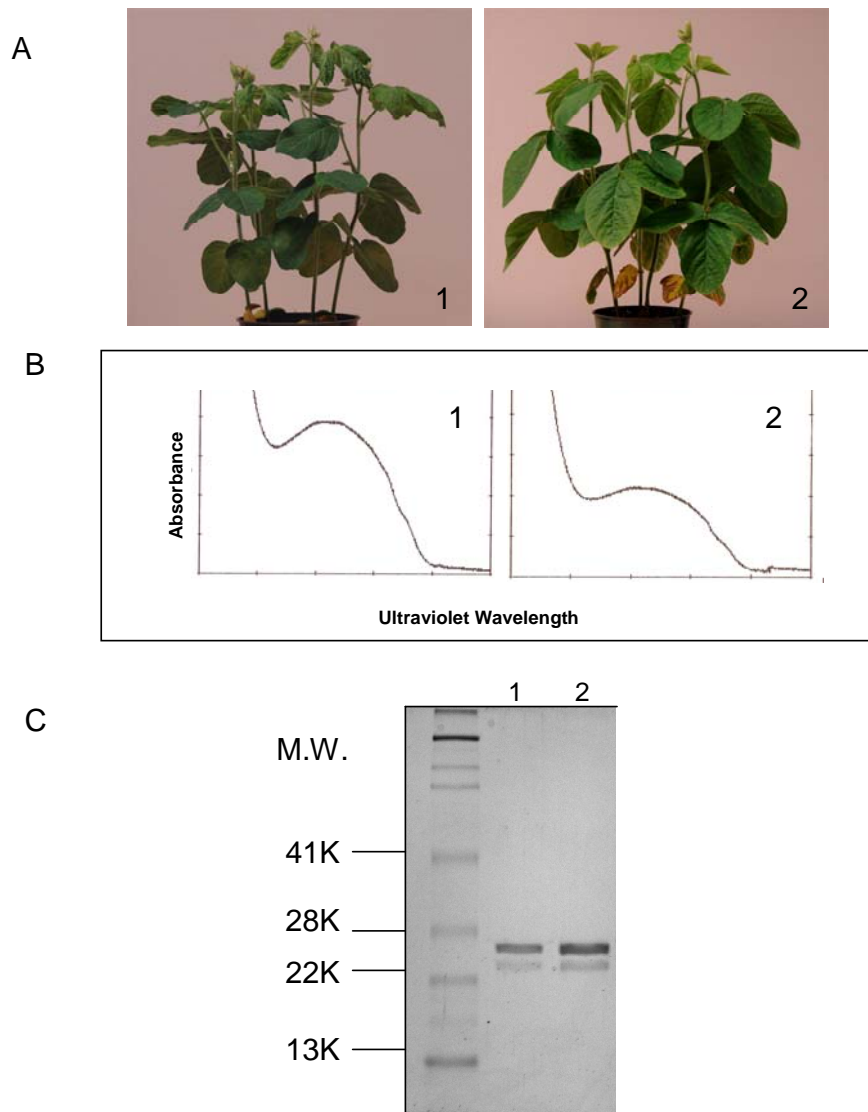

**Figure 2-6.** Characteristics of purified preparations of SMV strains (1) N and (2) G7. (A) Phenotypes of SMV strains on 'Williams 82' 21 days post-inoculation, (B) Ultraviolet absorbance spectra of purified preparations, and (C) detection of SMV CP by electrophoresis in 12% polyacrylamide gel following staining with coomassie blue.

## **Chapter III**

**Interactions between *Alfalfa mosaic virus* and**

***Soybean mosaic virus* in soybean**

## **Abstract**

Members of the *Potyviridae* are involved in different synergistic interactions. Generally in mixed-infection with other plant viruses, potyviruses usually enhance the accumulation of an unrelated virus. *Soybean mosaic virus* (SMV) has been shown to enhance the accumulation of *Bean common mosaic virus* and *Cowpea mosaic virus*, both members of the *Comoviridae* family, in double-infected soybean plants, resulting in disease synergism in both cases. *Alfalfa mosaic virus* (AMV) is an emerging virus disease of soybean in the United States in recent years, partly due to the arrival of soybean aphid (*Aphis glycines*) to these regions. AMV infection in soybean is associated with symptom remission even though the virus is still present in the infected plants. SMV is endemic in soybean growing areas of the United States, and with the recent increase in incidence of AMV in these areas, investigation of SMV interaction with AMV in soybean is warranted. To the best of my knowledge, no study on interaction between AMV and any member of *Potyviridae* family in any host has been reported to date.

In this study, interactions of three AMV with two SMV strains in two soybean cvs. Williams 82 and Lee 68 were investigated. Mixed-infection between AMV and SMV were easily established regardless of whether the viruses were inoculated simultaneously or sequentially. The disease synergism was expressed as an increase in symptom severity that was associated with an increase in the CP accumulation of AMV in a virus strain and soybean cultivar-independent manner. In contrast to AMV, SMV CP accumulation decreased in ‘Williams 82’ suggesting that interaction of SMV with AMV in soybean is

antagonistic. However, this antagonistic interaction was variable in soybean cultivar “Lee 68”.

### **3.1. Introduction**

Plants frequently are infected with more than one virus (8). This is because many viruses have common hosts and vectors. Mixed infection results in a number of different interactions between viruses and hosts. One common type of interaction is called viral synergism. Viral synergism occurs when two unrelated viruses simultaneously infect the same plant and the multiplication of one of the viruses is significantly enhanced; however, the multiplication of the other virus often remains unchanged (2, 7, 13, 27, 30, 34, 40). This phenomenon is not uncommon, since 69 virus species in 39 genera have been reported to be part of a synergistic interaction (21). Viruses can also interact in an antagonistic way, where one virus suppresses the accumulation of the other virus. Nevertheless, this phenomena is uncommon, and only two cases have been reported where the CP accumulation of one of the viruses is decreased (24, 26).

Viral synergism results in enhancement of plant damage and as a result symptom severity. Yield, plant weight as well as height of infected plant can be reduced (12, 25), and in extreme cases viral synergism can lead to plant death (12). On the other hand, viral synergism results in an enhancement in accumulation of one of the viruses possibly due to accumulation in other cell types, infection of a higher number of cells, or an increase in the number of particles per cell (15, 30, 46). Furthermore, there are some instances of mixed-infection where the genome of one virus is encapsidated in the coat protein (CP)

of the other virus. This phenomenon is known as transencapsidation, and may result in transmission of a virus by a new vector (29). In nature, it has been shown that the aphid *Rhopalosiphum padi* transmits *Barley yellow dwarf virus*, isolate MAV in mixed-infected plants with the serologically-unrelated isolate RPV, mainly due to the encapsidation of nucleic acid of MAV in the CP of RPV (29).

The interaction between *Potato virus X* (PVX) and *Potato virus Y* (PVY) in tobacco plants is the most studied example of potyviral synergism (15, 34, 41). This interaction is characterized by an increase in symptom severity and up to 10-fold PVX accumulation compared with single-infected plants. In synergistic interactions involving a potyvirus, the increase of the titer of the non-potyvirus is attributed to the helper-component proteinase (HC-Pro). The HC-Pro of the potyviruses represents the first plant viral suppressor of gene silencing that was identified (1, 6, 20, 40). Mutations in the coding region of the central domain of HC-Pro are unable to induce synergism (34), and fail to suppress gene silencing (20), suggesting that the two functions are closely related (14, 33). Several synergistic interactions involving potyviruses with non-potyviruses have been examined in detail, such as the interaction of *Soybean mosaic virus* (SMV) with *Bean pod mottle virus* (BPMV) or *Cowpea mosaic virus* (CPMV) (2, 7, 18). The outcome of these interactions has been an increase in yield reduction as well as an enhancement in symptom severity compared with the infection with each virus separately.

Soybean is a host for *Alfalfa mosaic virus* (AMV) and SMV. AMV is a highly variable virus (4), and its host range includes other agriculturally valuable crops (23). In nature, AMV is transmitted by pollen, seeds or aphids (39). At least 15 aphid species are

known to transmit AMV in a non-persistent manner (39). AMV is an emerging virus disease of soybean in the U.S. due to the recent introduction of the soybean aphid (*Aphis glycines*) (23). The aphid occurs in more than 20 states and three Canadian provinces (9, 44). In Wisconsin, AMV has been a factor in yield reduction by 31 and 26% in 2002 and 2003, respectively (23).

SMV has a narrow host range and it is present in soybean growing areas worldwide. It is the most common viral disease of soybean and is capable of reducing yield up to 90% (10). SMV encoded HC-Pro protein inhibits gene silencing in soybean plants (47). SMV interacts in a synergistic manner with two members of the genus *Comovirus*, CPMV and BPMV (2, 18, 28, 31, 32, 36). In both cases, mixed-infection has resulted in an increase in symptom severity and an increase in the CP accumulation of either CPMV or BPMV; nevertheless, the CP accumulation of SMV remained the same (2).

Since AMV is an emerging viral disease of soybean in the U.S., and SMV is an endemic virus, it is important to find out if the presence of both viruses in one plant results in disease synergism. AMV is a highly variable virus and the presence of many SMV strains has been reported. Thus, it is important to determine if such a synergism would be virus-strain and soybean-genotype-independent. This thesis examines the interactions between different isolates of AMV and SMV in soybean cvs. Williams 82 and Lee 68.

## **3.2. Materials and methods**

### ***A. Viruses***

#### ***1. Selection of AMV strains***

The AMV strains Joe Davis (JD) and Champaign (Ch) used in this study were kindly provided by Dr. L. Domier (University of Illinois, Urbana-Champaign), and AMV S0118 by Dr. S. Tolin (Virginia Tech). Biological clone of each of the three isolates were obtained by serial local lesion transfers on *Phaseolus vulgaris* and *Vigna unguiculata* (Table 2.3). The resultant biological clones were propagated in soybean cv. Colfax.

#### ***2. Selection of SMV strains***

Progeny derived from molecularly cloned SMV strains G7 (17) and N (44) in soybean ‘Williams 82’ were obtained from the University of Tennessee-Virology Lab.

#### ***3. Plants, inoculation and propagation of infected plants***

Soybean cvs. Williams 82 and Lee 68, both susceptible to AMV and SMV (3), were used. Plants were grown in a temperature-controlled growth chamber at 25°C with a photoperiod of 16 hours. Inoculation of soybean plants was conducted mechanically by rubbing the carborundum-dusted (600 mesh) fully expanded unifoliate leaves. Soybean plants were inoculated with either infectious sap at 1:10 (wt/vol) dilution ratio, or with purified virus at a concentration of 10 µg/plant. The infectious sap was obtained by grinding young leaves of infected soybean plants at 1:10 (wt/vol) dilution ratio in 0.1M (11) and 0.01M phosphate buffer, pH 7.1, for SMV and AMV, respectively. For the co-inoculation format, infectious sap containing AMV and SMV virions was mixed (1v:1v)

and 10 ul of inoculum was applied to each carborundum-dusted unifoliate leaf. For single inoculation, sap from virus-free plants was mixed with infectious sap containing either AMV or SMV virions (1v:1v), and 10 ul of inoculum was applied to each carborundum-dusted unifoliate leaf.

## ***B. Determination of AMV and SMV CP accumulation in soybean***

### ***1. Antigen coated indirect ELISA***

Antigen coated indirect ELISA (Ag-IELISA) was used to monitor the CP accumulations of SMV and AMV according to Jaegle and Van Regenmortel (19) with minor changes. Antibodies against AMV, SMV, and alkaline phosphatase-conjugated goat anti-rabbit IgG (Sigma-Aldrich, St. Louis, MO, USA) were diluted in Tween-phosphate buffered saline (TPBS) at pH 7.4 (1L phosphate-buffered saline + 0.5 ml Tween-20) + 5% non-fat dry milk. ELISA was performed in polystyrene plates (Fisher Scientific, Pittsburgh, PA, USA), which were washed three times with TPBS after each step. Leaf material was extracted in phosphate buffered saline (PBS) pH 7.4, at a dilution of 1:10 (wt/vol), clarified, and the extract was added to the appropriate wells. The plate was incubated for 1 h at 37°C. After adding 200 µl of blocking solution (PBS + 5% non-fat dry milk) to each well, the plate was incubated overnight at 4°C. Either anti-AMV or anti-SMV polyclonal antibodies at a dilution of 1:1000 were added to each well. Following incubation for 1 h at 37°C, alkaline phosphatase conjugated goat anti-rabbit IgG antibodies were diluted (0.6 µl/ml) and added to the wells. Plates were incubated for 1 h at 37°C and diethanolamide (Sigma-Aldrich) substrate buffer at pH 9.8 was stirred with p-nitrophenyl phosphate (Sigma- Aldrich) at a dilution of 0.5 mg/ml and added to

the plate. Absorbance, at 405 nm, of each reaction was monitored in a Bio-Rad ELISA reader Model 680.

The main effects and interactions of AMV and SMV CP accumulation based on ELISA readings were analyzed for significance using Proc Mixed of PC-SAS ver. 9.1.3 (SAS, Cary, NC). Significant effects were further analyzed with an F-protected least significant difference test at  $P = 0.05$ .

### ***C. Mixed-viral infection experiments***

#### ***1. Attempt to establish mixed- infection between SMV and AMV***

‘Williams 82’ plants were mechanically inoculated with AMV-JD and SMV-N. Three treatments of virus combinations were performed. Three plants per treatment were inoculated in a simultaneous or sequential format (AMV first and SMV 4 hours later or vice versa) (Table 3.1.). The entire experiment was repeated two times, using either infectious sap or purified virus as a source of inoculum. A control mock inoculation was included in both experiments. For the first trial, 10  $\mu$ l of infectious sap was applied for the single virus inoculation, and a mixture of 20  $\mu$ l (10  $\mu$ l of infectious sap containing each virus) was applied for the co- inoculation format. For the second trial, purified virus applied at a concentration of 10  $\mu$ g/plant for single virus inoculation and a mixture of 20  $\mu$ g (10  $\mu$ g of each virus) for the co-inoculation format. Virus symptoms were recorded 21 and 30 days-post inoculation (dpi). For all treatments, the middle trifoliolate of each trifoliolate leaf was sampled, weighed and sap was extracted in PBS buffer. The concentration of CP of AMV and SMV was determined by Ag-IELISA.

## ***2. Evaluation of AMV and SMV accumulation in single or double-inoculated plants***

The change in CP accumulation and the increase in symptom severity as a result of dual infections were analyzed. Three AMV and two SMV isolates were co-inoculated in combinations of two and the accumulation of CP was compared with infection produced by each of the viruses alone in soybean cvs. Williams 82 or Lee 68. The experimental design used for each combination is presented in Fig. 3.1 and the combination of viruses used was the following: SMV-N/AMV-JD, SMV-N/AMV-Ch, SMV-N/AMV-S0118, SMV-G7/AMV-JD, SMV-G7/AMV-Ch and SMV-G7/AMV-S0118. For single virus inoculation, 10 µg of purified virus/plant was applied to unifoliate leaves whereas a mixture of 20 µg (10 µg of each of the viruses) for double-inoculated plants. Each virus combination experiment was conducted three or four times, and samples were taken 21 and 30 dpi. Plants were sampled by taking a middle trifoliolate from each trifoliolate leaf; however, for final analysis the sample consisted of one disc (area ~ 0.8 cm<sup>2</sup>) taken from one trifoliolate of each trifoliolate leaf. Disks from each plant were combined, weighed, sap was extracted in PBS buffer, clarified by brief centrifugation for 10 min at 10,000 rpm, and the supernatant was used to determine the CP concentration of AMV and SMV by Ag-IELISA (19).

A final experiment was conducted to validate the earlier experiments by increasing the number of replicate plants. Each treatment consisted of 15 replicate plants. The isolates chosen were SMV-N, SMV-G7 and AMV-JD in soybean cv. Williams 82. Plants were inoculated with 10 µg of purified virus/plant for single and a mixture of 20

µg (10 µg of AMV and 10 µg of SMV/plant) for double-inoculation treatments. Plants were analyzed 21 dpi by antigen coated indirect ELISA by sampling one disc (area ~ 0.8 cm<sup>2</sup>) per trifoliolate of each trifoliolate leaf per plant. The samples were processed as above.

### **3.3. Results**

#### ***A. Establishment of mixed-infection between AMV-JD and SMV-N in soybean cv. Williams 82 is irrespective of whether the isolates are inoculated simultaneously or sequentially***

To examine the possibility of establishing mixed-infection between AMV and SMV in soybean, AMV-JD and SMV-N isolates were chosen because each virus produced characteristic symptoms on ‘Williams 82’ that could be used to distinguish mixed- infections from single-infections. Infected plants with AMV-JD developed strong chlorosis and mosaic in lower trifoliates, whereas the rest of the plant had milder symptoms. AMV-JD symptom remission was associated with a decrease in CP accumulation of the virus among trifoliates (Fig. 3.2); however, the virus was still detectable from the symptomless leaves and produced necrotic lesions in cowpea and bean plants. SMV-N induced severe leaf rolling and deformation in the upper trifoliates, specifically on trifoliolate 3. This was correlated with a higher virus concentration in the trifoliolate (Figs. 3.3 and 3.4).

Mixed-infections of AMV-JD and SMV-N were easily established. This was irrespective of simultaneous or sequential inoculation of the two viruses (Table 3.2).

The disease synergism was associated with new symptoms that were different from those induced by AMV-JD or SMV-N induced symptoms in single-infected plants alone. Dually infected soybean plants developed dramatic leaf deformation, mottling, mosaic, and stunting (Fig. 3.5). No significant symptom variation among the three inoculation treatments was noted (Fig. 3.5).

AMV-JD CP accumulation was significantly enhanced ( $P < 0.0001$ ) when plants were co-infected with SMV-N compared with single-infected plants with AMV-JD alone (Table 3.2). These results were irrespective of the inoculation format used. Nevertheless, AMV-JD enhancement was more pronounced in sequential inoculation as compared with simultaneous format (Table 3.2). A middle fully expanded trifoliolate from each trifoliolate leaf was analyzed for CP accumulation. The AMV CP concentration was consistently enhanced in all the trifoliate assayed (Fig. 3.6). Significant differences ( $P < 0.0001$ ) in AMV CP concentration among trifoliate were still detected at every leaf position (Fig. 3.6A). Analyses of enhancement of AMV-JD accumulation by trifoliolate showed that it was not homogeneous throughout the plant (Fig. 3.6A). Similar observations were made following sequential inoculation of the plants.

The enhancement of AMV CP accumulation in dual-infected plants was correlated with the presence of SMV in all trifoliate (Fig. 3.6B, Table 3.2B), suggesting that mixed-infection between both viruses can be established independently of the inoculation format used. This is similar to the interaction reported between SMV and BPMV (2), where BPMV was significantly enhanced in double-infected plants at all leaf positions. Therefore, since simultaneous inoculation is a faster method to establish

mixed-infection, this format was chosen for further experiments. Interestingly, SMV-N CP accumulation decreased in dual-infected plants in all three inoculation formats.

***B. Synergism between AMV and SMV is AMV strain independent***

***1. Mixed-infection of AMV isolates and SMV-N in ‘Williams 82’ results in enhancement of symptom severity***

To determine if the synergistic interaction between AMV and SMV is strain specific and occurs only with AMV-JD, two other AMV isolates, AMV-Ch and S0118, were chosen for further experimentation. Single and mixed-infections caused by AMV and SMV isolates in ‘Williams 82’ is summarized in Table 3.3. AMV-Ch induced mosaic, mild stunting, chlorosis, and eventually symptom remission in the upper trifoliates; symptoms induced by AMV-S0118 were more or less similar to AMV-Ch.

Infections of SMV-N with AMV- JD, Ch and S0118 generated disease synergism, where phenotypes of both viruses were present. In general, dual-infected ‘Williams 82’ plants had more pronounced stunting, chlorosis and severe mosaic, accompanied with leaf deformation, compared to single-infected plants with each of the viruses individually. The phenotypical markers of SMV-N in the third and fourth trifoliolate leaves were distinguishable in all the interactions except SMV-N and AMV-JD, where plants were severely deformed (Figs. 3.5, 3.7 and 3.8). Similar observations were made if the symptoms were recorded 14, 21 or 30 dpi. However, the severity of symptoms was more pronounced with the combination of SMV-N and AMV-JD. Similar results were obtained in different experiments, where double-infected plants exhibited the same pattern of symptom enhancement (Fig. 3.8). Symptoms were more pronounced in trifoliates 2 and 3

than in the other trifoliates (Fig. 3.9). Double-infected plants had a delay in symptom development compared with either AMV- or SMV-infected plants alone. However, symptoms induced by AMV isolates consistently appeared faster than SMV strains alone.

Co-infection between SMV-N and AMV-S0118 was not consistently detected immunologically and phenotypically. Four independent experiments were conducted to study the behavior of these isolates when they were co-inoculated to soybean plants. In two out of four experiments, both viruses were detected, and infected plants had symptoms characteristics of AMV-S0118 and SMV-N (Fig. 3.10). Double-infected plants had greater symptom severity in trifoliolate 3 (Fig. 3.10), similar to what was observed in the interaction between SMV-N and AMV-Ch. However, in the other two experiments, plants had only symptoms characteristic of AMV-S0118, but not SMV-N. SMV-N was not detected by Ag-IELISA in those plants.

## ***2. Mixed-infection of AMV isolates and SMV-N in 'Williams 82' results in enhancement in CP accumulation of AMV***

Ag-IELISA was conducted to evaluate virus antigen titer in single and double-infected soybean cv. Williams 82. AMV CP accumulation was significantly enhanced ( $P < 0.05$ ) in plants co-infected with SMV-N as compared to AMV infection alone (Table 3.4). These results were consistent for the interactions between SMV-N and AMV isolates JD, Ch and S0118 (Table 3.4). Similar results were obtained in different independent experiments, where samples were taken at 21 and 30 dpi. However, the increase of AMV-S0118 accumulation was dependent on the amount of SMV-N present

(Table 3.4). Nevertheless, when SMV-N was not detectable immunologically, AMV-S0118 CP accumulation was still enhanced, but not significantly (Table 3.4).

Overall, the enhancement of the three AMV isolates was consistent among trifoliates, when samples were taken from a middle trifoliolate from each trifoliolate (Figs. 3.6, 3.11 and 3.12). The CP accumulation of AMV isolates used in this study was increased between 30 and 250% in double-infected plants at 21 and 30 dpi, respectively, as compared with each isolate in single infection (Tables 3.2 and 3.4). Thus, the disease synergism induced by co-inoculation of SMV-N and AMV isolates used in this study appears to be AMV strain independent.

### ***3. Mixed-infection of AMV isolates and SMV-N in 'Williams 82' results in decrease in CP accumulation of SMV***

In contrast to the increase in AMV CP, the accumulation of SMV-N CP was significantly decreased ( $P < 0.01$ ) in dual-infected plants, regardless of the AMV isolates used and the time of sampling (Tables 3.2 and 3.4). However, the reduction in SMV-N was not consistent among trifoliates. In fact, the CP concentration in trifoliolate 1 increased in the three interactions (Figs. 3.5, 3.11 and 3.12). Overall, SMV-N titer dropped between 10 and 20% at 21 and 30 dpi compared with SMV-N alone (Tables 3.2 and 3.4). In the interaction between AMV-S0118 and SMV-N, the decrease of SMV CP accumulation was variable. SMV accumulation dropped between 10 and 100% (Table 3.4). Based on these observations, there is an antagonistic interaction between SMV-N and the AMV isolates used in this study that is AMV strain independent.

### *C. Synergism between AMV and SMV is SMV strain independent*

#### *1. Mixed-infection of AMV isolates and SMV-G7 in 'Williams 82' results in an enhancement in symptom severity*

It has been suggested that the extend of the synergistic interaction between SMV and BPMV is SMV strain dependent (31). To find out if similar results would occur in the pathosystem used in this study, SMV-G7 was chosen due to its milder phenotype as compared to SMV-N in order to determine if the disease synergism between AMV and SMV is SMV strain dependent. SMV-G7 induced mild mosaic and stunting in soybean. Results of single and mixed-infection induced by SMV-G7 and AMV-JD, Ch and AMV-S0118 in 'Williams 82' are summarized in Table 3.5.

In the case of co-infection of soybeans with AMV isolates, plants also had an increased in symptom severity as compared to SMV-G7 infection alone. Dual-infected plants had more stunting, leaf deformation, and mosaic. The disease synergism of AMV-JD and SMV-G7 induced severe symptoms in dual-infected plants compared to the interactions between AMV-Ch and AMV-S0118 with SMV-G7 (Figs. 3.13 and 3.14). Similar results were obtained in different experiments, where double-infected plants had the same pattern of symptom enhancement (Fig. 3.14). Symptoms were more pronounced in trifoliolate 3 (Fig. 3.15). Furthermore, there was a delay in symptom development in double-infected plants compared with either AMV-, or SMV-infected plants alone. These results were consistent with the interactions between SMV-N and AMV-JD. In addition to an increase in symptom severity, eventually plants co-infected with AMV-Ch and SMV-G7 had symptom remission in the upper trifoliates following the same pattern as

when the AMV isolate was inoculated alone. The interaction between SMV-G7 and AMV-S0118 was also difficult to establish.

Two independent experiments were performed and the results were similar to the pattern obtained with SMV-N and AMV-S0118 interactions. In the first experiment, the infected plants showed an increase in symptom severity; symptoms induced by both viruses were apparent, and the presence of the viruses was confirmed by Ag-IELISA. In contrast, in the second experiment co-inoculated plants only had symptoms induced by AMV-S0118, and SMV-G7 ELISA values were low, but higher than readings for background.

***2. Mixed-infection of AMV isolates and SMV-G7 in ‘Williams 82’ results in an enhancement in CP accumulation of AMV***

As with AMV CP concentration enhancement by SMV-N; SMV-G7 also significantly enhanced AMV-JD CP concentration ( $P < 0.05$ ). Double-infected plants had an increase in AMV CP accumulation in all the trifoliates (Fig. 3.16); nonetheless, in contrast to the interaction between SMV-N and AMV-JD, there was not a significant difference among trifoliates in double-inoculated plants (Fig. 3.16). Subsequent to this observation, sampling of further experiments was done by taking one disc per trifoliolate from each of the trifoliolate leaves. All disks were combined together and were analyzed as one sample for each inoculated plant. Furthermore, since no differences in the enhancement of CP accumulation at 21 and 30 dpi was observed in the previous experiments, sampling was done only at 21 dpi in subsequent experiments.

SMV-G7 also significantly enhanced the accumulation of AMV-Ch in double-infected plants. Accumulation of AMV-S0118 in mixed-infection was increased, but the difference was not significant (Table 3.6). The increase in AMV-S0118 CP accumulation depended on the amount of SMV-G7 present in the infected plants; nevertheless, symptoms enhancement was not as pronounced as compared with the other interactions. AMV-S0118 CP accumulation was enhanced up to 400% ( $0.73 \pm 0.02$ ) compared to AMV alone ( $0.18 \pm 0.02$ ), if SMV-G7 was present in higher amount ( $0.5 \pm 0.05$ ) in dually-infected plants. Nevertheless, SMV-G7 CP accumulation was still decreased as compared with single-infected plants ( $0.9 \pm 0.05$ ). AMV-S0118 and SMV-G7 interactions represent an example where AMV CP was greatly enhanced in a mixed-infection experiment. Overall, the antigen titer enhancement of AMV isolates used in this study by SMV-G7 was between 30 and 50% in double-infected plants compared with single infected virus alone (Table 3.6).

### ***3. Mixed-infection of AMV isolates and SMV-G7 in 'Williams 82' results in decrease in CP accumulation of SMV***

In contrast to AMV enhancement, the accumulation of SMV-G7 decreased in dual-infected plants as compared with single infection (Table 3.6). Nevertheless, the level of reduction among interactions was different, and the same result was obtained in repeated independent experiments. Similar to the observations made in earlier experiments with mixed-infection of SMV-N with the three AMV isolates used in this study, SMV-G7 CP accumulation in double-infected plants with AMV-JD, decreased in all trifoliates except trifoliolate one (Fig. 3.16). SMV CP accumulation decreased

significantly ( $P < 0.001$ ) in the interactions between AMV-Ch and AMV-S0118; nevertheless, in the presence of AMV-JD, SMV-G7 accumulation dropped, but the reduction was not significant (Table 3.6). Overall, SMV-G7 CP accumulation in double infected plants dropped between 20 and 60% at 21 dpi compared with SMV infected plants alone (Table 3.6). The decrease in SMV-G7 CP accumulation in plants co-infected with AMV-S0118 varied, but followed the same pattern of interaction between AMV-S0118 and SMV-N.

To confirm these observations, an independent experiment was conducted between AMV-JD, SMV-G7, SMV-G7/AMV-JD, SMV-N, SMV-N/AMV-JD, where the number of replicate plants was increased. The experiment was conducted with 15 replicate plants for each treatment. AMV-JD was significantly enhanced in mixed-infection with both SMV strains N and G7. On the contrary, SMV-N was significantly reduced in dual-infected plants, following the same pattern as in previous experiments, SMV-G7 decreased, but the level of reduction was not significant (Fig. 3.17).

#### ***D. Synergism between AMV and SMV is soybean genotype independent***

##### ***1. Mixed-infection of AMV isolates and SMV strains in ‘Lee 68’ results in an enhancement in symptom severity***

To investigate the possibility that synergistic interaction of AMV with SMV is also dependant on soybean-genotype, soybean cv. Lee 68, susceptible to both viruses (3), was used. In general, AMV and SMV isolates alone induced similar symptoms in Lee 68 as those in ‘Williams 82’ (Tables 3.3, 3.5 and 3.7). However, ‘Lee 68’ plants infected with SMV-G7 were the only ones that had a different pattern of symptoms. SMV-G7

induced a mild mosaic around 10 dpi, but approximately two weeks post-inoculation plants were almost symptomless.

The interactions between SMV-N and SMV-G7 with the three AMV-isolates (JD, Ch and S0118) generated disease synergism in ‘Lee 68’. Soybean plants co-inoculated with SMV-G7 and AMV-S0118 were symptomless; nevertheless, the presence of the viruses was immunologically detected within plants.

Overall, the interactions between AMV-JD and SMV-N (Fig. 3.18), and AMV-JD with SMV-G7 induced more severe symptoms. Plants had a greater degree of stunting, leaf deformation, chlorosis and mosaic. Dual-infected plants (AMV-Ch with either of the SMV isolates) also had more stunting compared with plants infected with each of the viruses alone (Figs. 3.19 and 3.20). Nevertheless, symptoms were more pronounced in the co-infection with SMV-N (Fig. 3.19). The interaction between SMV-N and S0118 followed the same behavior as was observed in ‘Williams 82’ (Fig. 3.21).

## ***2. Mixed-infection of AMV isolates and SMV strains in ‘Lee 68’ results in an enhancement of AMV CP accumulation***

The presence of viruses in the inoculated ‘Lee 68’ was determined by Ag-IELISA 21 dpi. In a number of independent experiments, the accumulation of AMV-JD and AMV-Ch was significantly enhanced ( $P < 0.05$ ) by the presence of either SMV-N or SMV-G7 (Table 3.8 and Figs. 3.22 to 3.24). This result was consistent with results obtained in ‘Williams 82’. In the interaction between AMV-S0118 and both SMV strains, AMV accumulation was enhanced, but not significantly. However, in contrast to results obtained between SMV-G7 and AMV-S0118 in ‘Williams 82’, the presence of SMV-G7

in ‘Lee 68’ was consistently detected. Overall, AMV isolates were enhanced by SMV-G7 between 40 and 140% in double-infected plants. This suggests that the disease synergism between AMV and SMV is strain-independent, but also is soybean genotype independent.

### ***3. Mixed-infection of AMV isolates and SMV strains in ‘Lee 68’ results in decrease in CP accumulation of SMV***

In contrast with the results obtained in ‘Williams 82’, mixed-infection of SMV-N and SMV-G7 with AMV isolates did not result in significant decrease in CP accumulation of SMV strains in all the interactions. However, the reduction of SMV-N and SMV-G7 CP accumulation in mixed-infection with AMV-S0118 was highly significant ( $P < 0.01$ ) (Table 3.8 and Figs. 3.22 to 3.24).

Since the results between AMV-S0118 and SMV-N in ‘Williams 82’ and ‘Lee 68’ were not consistent, an independent experiment was conducted and the number of replicate plants was increased to ten for both soybean cultivars. The outcome was 3/10 plants co-inoculated with both viruses had symptoms corresponding to AMV and SMV, and both viruses were detected immunologically in the infected plants. On the other hand, the remaining seven plants had symptoms characteristics of AMV infection only. The infected plants were immunologically analyzed for the presence of AMV and SMV, and both viruses were detected in all the plants. The presence of SMV was not clear due to low ELISA readings, but it was confirmed in one of the plants by RT-PCR (data not shown). AMV-S0118 CP was enhanced significantly only in ‘Williams 82’ (Table 3.9). On the other hand, SMV-N CP concentration was significantly decreased in both

cultivars in mixed-infections (Table 3.8). Nevertheless, the higher values of SMV-N detected by Ag-IELISA were correlated with higher amounts of AMV-S0118 in double-infected plants. This suggests that AMV-S0118 CP concentration enhancement depends on the amount of SMV in the infected tissues. However, there is a strong antagonistic interaction between both viruses. Hence, it is unlikely that mixed-infection between an AMV and SMV isolate with genotypes similar to those of SMV-N and SMV-S0118 can survive under natural conditions.

### **3.4. Discussion**

Based on the results presented in this thesis, mixed-infection between AMV and SMV can be easily established where the outcome is a disease synergism with greater symptom severity and an enhancement of AMV CP accumulation. SMV-N and SMV-G7 enhanced the accumulation of the three AMV isolates used in this study in soybean cvs. Williams 82 and Lee 68. The finding that SMV-N enhanced AMV isolates CP accumulation to a greater degree compared with SMV-G7 is not unexpected; since in the interaction between SMV and BPMV the effect of SMV on the synergistic interaction was SMV-strain dependent (31).

Mixed-infection between AMV and SMV was easily established irrespective of whether the viruses were inoculated in a sequential or simultaneous format; which correlates with the synergistic interactions observed between SMV and BPMV (2). Nevertheless, it was interesting to observe that even though AMV CP enhancement was significantly different in the three inoculation formats tested; the enhancement was more

pronounced in the sequential than in the simultaneous format. This result was irrespective of whether AMV or SMV was inoculated first or second. On the other hand, SMV-N CP accumulation decreased in dual-infected plants in all three inoculation formats.

In this study, all the mixed-infected soybean plants, except AMV-S018 and SMV-G7 in 'Lee 68' exhibited severity of symptoms similar to reports in other interactions involving members of the *Potyviridae* family (37). This result was not surprising, since SMV-G7 is a milder isolate compared to SMV-N. Overall, plants in every interaction tested had more severe stunting, leaf deformation, necrosis, mosaic and chlorosis compared with infection with each virus alone. Furthermore, AMV JD co-infected with either SMV-N or SMV-G7, caused the most severe foliage symptoms, including stunting, in both soybean cultivars. Interestingly, besides these interactions where plants were very deformed, in the remainder of co-inoculated plants symptoms induced by each of the viruses were observed. This was particularly noticeable for infections with the SMV-N strain, where infected plants continuously showed leaf rolling in trifoliolate 3 or 4.

Enhancement of AMV isolates was independent of the strain of AMV and SMV, and independent of soybean genotype. It has been observed that HC-Pro suppresses gene silencing in new and old leaves (43). The enhancement of AMV CP accumulation was at all leaf positions, following the same pattern of enhancement as in the interaction between SMV and BPMV (2). This was consistent with the interactions of the three AMV isolates tested with SMV strains N, and G7. This was remarkable since it shows that SMV has the ability to enhance AMV in all leaf positions, suggesting that SMV has the capability to suppress gene silencing machinery in soybean in all the trifoliolate leaves,

which correlates with the observation that HC-Pro suppresses gene silencing in old as well as new leaves (43).

While further studies are needed to understand the underlying mechanism of this synergistic interaction, a hypothesis could be proposed. SMV enhances AMV symptom expression, similar to other potyviruses studied (37). The ability of potyviruses to mediate disease synergism in interaction with non-potyviruses, has been attributed to the gene-silencing suppressor activity of HC-Pro (1, 6, 20, 40).

SMV encodes HC-Pro, which has been reported to suppress the gene silencing machinery in soybean (47). This could be correlated with the reports of BPMV CP enhancement in the presence of SMV (2). It has been shown that lacks gene silencing suppressor activity (16) similar to AMV (43). HC-Pro has also been shown to be involved in long distance movement (38), which could facilitate AMV movement through the plant by transcomplementation. Another possibility could be that AMV enhancement in the presence of SMV is the result of an increase of virus particles per cell, as is the case with PVX-PVY in tobacco plants (15), or an increase in the number of infected cells. However, it has been shown that in mixed infection, SMV does not change the pattern of replication of other viruses (2).

Surprisingly SMV-N and SMV-G7 CP accumulation decreased in dual-infected in ‘Williams 82’ plants. In mixed-infection involving potyviruses and non-potyviruses, decrease in CP accumulation of a potyvirus has been rarely observed, and to the best of my knowledge, it has been reported in only two systems (24, 26). However, no such observation has been reported for SMV. The decrease in SMV CP accumulation was not

consistent in all trifoliates. Unlike all the other trifoliates, accumulation of CP in trifoliolate 1 was higher than the corresponding trifoliolate from plants infected with SMV alone. This difference could be attributed to the distribution pattern of potyvirus particles in infected tissue (35).

The mechanism by which AMV suppresses SMV CP accumulation is unknown. Similarly it is not known why SMV accumulation decreases in the presence of AMV. AMV symptoms appeared 4 to 5 dpi, while SMV-N symptoms are visible around 7 dpi, and in the case of SMV-G7 symptoms appeared 8-12 dpi. This suggests that AMV replication is faster than that of SMV strains N and G7. One possibility is that SMV competes with AMV for sites of replication or other cellular resources such as nucleotides, amino acids, etc. Thus, there could be no adequate sites or other cellular resources available for SMV to replicate efficiently once utilized for replication of AMV. The antagonistic interaction of SMV with AMV was consistently observed in 'Williams 82'; however, results were variable in 'Lee 68'. Out of three interaction experiments conducted in 'Lee 68', antagonism between SMV and AMV was observed only in two experiments. Nonetheless, the interaction between SMV strains N and G7 with AMV-S0118 was consistent, irrespective of the cultivar used. The reason for variability in the degree of antagonism among the experiments is unknown. Nevertheless, it has been reported that AMV isolates replicate in different parts of the cells (35).

The interactions between both SMV strains and AMV-S0118 were of particular interest. Despite a constant decrease in SMV CP accumulation in double-infected plants with AMV-S0118, there was always a higher accumulation of CP of AMV-S0118. There

was also a direct correlation between the level of SMV present in the infected tissues and enhancement of AMV CP accumulation. This indicates that the level of HC-Pro may be critical for enhancement of AMV accumulation.

The work reported here demonstrates for the first time provides experimental evidence in regard to synergistic interactions between AMV and SMV, and the antagonistic interactions between SMV and AMV in soybean. The synergistic interaction between AMV and SMV is alarming for soybean growers due to the introduction of the new soybean aphid, which is believed to be present in 80% (42) of the soybean fields in the U.S, and has been shown capable of transmitting both AMV and SMV (23).

The recent increase in incidence of AMV in soybean growing areas of the U.S. is attributed to the introduction of soybean aphid to these regions. As a consequence, AMV has become an emerging disease in the U.S (23). Therefore, in areas where SMV and AMV are presents, soybean plants could be infected with a mixture of these two viruses. Since it was shown that disease synergism is viral strain and soybean genotype independent, its occurrence under the field conditions is not unlikely. Furthermore,, SMV also has been reported to be transmitted by the soybean aphid (45) which could lead to transmission of AMV and SMV as a mixture of viruses. This could also occur through transencapsidation, where the genome of a virus is encapsidated in the CP of another virus; this phenomenon has been shown to result in the transmission of the viruses by a new vector (5, 22, 29).

## References cited

1. Anandalakshmi, R., Pruss, G. J., Ge, X., Marathe, R., Mallory, A. C., Smith, T. H., and Vance, V. B. 1998. A viral suppressor of gene silencing in plants. *Proc. Natl. Acad. Sci. USA.* 95:13079-13084.
2. Anjos, J. R., Jarlfors, U., and Ghabrial, S. A. 1992. Soybean Mosaic Potyvirus Enhances the Titer of 2 Comoviruses in Dually Infected Soybean Plants. *Phytopathology* 82:1022-1027.
3. Bernard, R. L., Nelson, R. L., and Cremeens, C. R. 1991. USDA soybean genetic collection: isoline collection. *Soyb. Genet. Newsl.* 18: 27–57.
4. Bol, J. F. 2003. *Alfalfa mosaic virus*: coat protein-dependent initiation of infection. *Mol. Plant Pathol.* 4:1-8.
5. Briddon, R. W., Pinner, M. S., Stanley, J., and Markham, P. G. 1990. Geminivirus Coat Protein Gene Replacement Alters Insect Specificity. *Virology* 177:85-94.
6. Brigneti, G., Voinnet, O., Li, W. X., Ji, L. H., Ding, S. W., and Baulcombe, D. C. 1998. Viral pathogenicity determinants are suppressors of transgene silencing in *Nicotiana benthamiana*. *Embo J.* 17:6739-6746.
7. Calvert, L. A., and Ghabrial, S. A. 1983. Enhancement by Soybean Mosaic-Virus of Bean Pod Mottle Virus Titer in Doubly Infected Soybean. *Phytopathology* 73:992-997.
8. Candelier-Harvey, P., and Hull, R. 1993. Cucumber mosaic virus genome is encapsidated in alfalfa mosaic virus coat protein expressed in transgenic tobacco plants. *Transgenic Res.* 2:277-285.
9. Clark, A. J., and Perry, K. L. 2002. Transmissibility of field isolates of soybean viruses by *Aphis glycines*. *Plant Dis.* 86:1219-1222.
10. Dhingra, K. L., and Chenulu, V. V. 1980. Effect of Soybean mosaic virus on yield and nodulation of soybean cv. Bragg. *Indian Phytopath.* 33:586-590.
11. Furutani, N., Hidaka, S., Kosaka, Y., Shizukawa, Y., and Kanematsu, S. 2006. Coat protein gene-mediated resistance to *Soybean mosaic virus* in transgenic soybean. *Breed. Sci.* 56:119-124.

12. Garcia-Cano, E., Resende, R. O., Fernandez-Munoz, R., and Moriones, E. 2006. Synergistic interaction between *Tomato chlorosis virus* and *Tomato spotted wilt virus* results in breakdown of resistance in tomato. *Phytopathology* 96:1263-1269.
13. Goldberg, K.-B., and Brakke, M. K. 1987. Concentration of maize chlorotic mottle virus is increased in mixed infections with maize dwarf mosaic virus, strain B. *Phytopathology* 77:162-167.
14. Gonzalez-Jara, P., Atencio, F. A., Martinez-Garcia, B., Barajas, D., Tenllado, F., and Diaz-Ruiz, J. R. 2005. A single amino acid mutation in the *Plum pox virus* helper component-proteinase gene abolishes both synergistic and RNA silencing suppression activities. *Phytopathology* 95:894-901.
15. Goodman, R.M., and Ross, A. F. 1974. Enhancement of potato virus X synthesis in doubly infected tobacco occurs in doubly infected cells. *Virology* 58: 16–24.
16. Gu, H. C., and Ghabrial, S. A. 2005. The *Bean pod mottle virus* proteinase cofactor and putative helicase are symptom severity determinants. *Virology* 333:271-283.
17. Hajimorad, M. R., Eggenberger, A. L., and Hill, J. H. 2003. Evolution of *Soybean mosaic virus-G7* molecularly cloned genome in *Rsv1*-genotype soybean results in emergence of a mutant capable of evading *Rsv1*-mediated recognition. *Virology* 314:497-509.
18. Hobbs, H. A., Hartman, G. L., Wang, Y., Hill, C. B., Bernard, R. L., Pedersen, W. L., and Domier, L. L. 2003. Occurrence of seed coat mottling in soybean plants inoculated with *Bean pod mottle virus* and *Soybean mosaic virus*. *Plant Dis.* 87:1333-1336.
19. Jaegle, M., and Van Regenmortel, M. H. V. 1985. Use of ELISA for measuring the extent of serological cross-reactivity between plant viruses. *J. Virol. Methods* 11:189-198.
20. Kasschau, K. D., and Carrington, J. C. 2001. Long-distance movement and replication maintenance functions correlate with silencing suppression activity of potyviral HC-Pro. *Virology* 285:71-81.
21. Latham, J. R., and Wilson, A. K. 2008. Transcomplementation and synergism in plants: implications for viral transgenes? *Mol. Plant Pathol.* 9:85-103.

22. Lecoq, H., Ravelonandro, M., Wipfscheibel, C., Monsion, M., Raccach, B., and Dunez, J. 1993. Aphid Transmission of a Non-Aphid-Transmissible Strain of Zucchini Yellow Mosaic Potyvirus from Transgenic Plants Expressing the Capsid Protein of Plum Pox Potyvirus. *Mol. Plant-Microbe Interact.* 6:403-406.
23. Mueller, E. E., and Grau, C. R. 2007. Seasonal progression, symptom development, and yield effects of *Alfalfa mosaic virus* epidemics on soybean in Wisconsin. *Plant Dis.* 91:266-272.
24. Mukasa, S. B., Rubaihayo, P. R., and Valkonen, J. P. T. 2006. Interactions between a crinivirus, an ipomovirus and a potyvirus in coinfecting sweetpotato plants. *Plant Pathol.* 55:458-467.
25. Murphy, J. F., and Bowen, K. L. 2006. Synergistic disease in pepper caused by the mixed infection of *Cucumber mosaic virus* and *Pepper mottle virus*. *Phytopathology* 96:240-247.
26. Poolpol, P., and Inouye, T. 1986. Enhancement of cucumber mosaic virus multiplication by zucchini yellow mosaic virus in doubly infected cucumber plants. *Ann. Phytopathol. Soc. Japan* 52:22-30.
27. Pruss, G., Ge, X., Shi, X. M., Carrington, J. C., and Vance, V. B. 1997. Plant viral synergism: The potyviral genome encodes a broad-range pathogenicity enhancer that transactivates replication of heterologous viruses. *Plant Cell* 9:859-868.
28. Quiniones, S. S, Dunleavy, J. M., and Fisher, J. W. 1971. Performance of 3 Soybean Varieties Inoculated with Soybean Mosaic Virus and Bean Pod Mottle Virus. *Crop Sci.* 11:662-664.
29. Rochow, W. F. 1970. Barley Yellow Dwarf Virus. Phenotypic Mixing and Vector Specificity. *Science* 167:875-878.
30. Rochow, W. F., and Ross, A. F. 1955. Virus Multiplication in Plants Doubly Infected by Potato Virus-X and Virus-Y. *Virology* 1:10-27.
31. Ross, J. P. 1968. Effect of Single and Double Infections of Soybean mosaic virus and Bean pod mottle viruses on soybean yield and seed characters. *Plant Dis. Rep.* 52:344-348.

32. Ross, J. P. 1969. Effect of Time and Sequence of Inoculation of Soybeans with Soybean Mosaic and Bean Pod Mottle Viruses on Yields and Seed Characters. *Phytopathology* 59:1404-1410.
33. Saenz, P., Salvador, B., Simon-Mateo, C., Kasschau, K. D., Carrington, J. C., and Garcia, J. A. 2002. Host-specific involvement of the HC protein in the long-distance movement of potyviruses. *J. Virol.* 76:1922-1931.
34. Shi, X. M., Miller, H., Verchot, J., Carrington, J. C., and Vance, V. B. 1997. Mutations in the region encoding the central domain of helper component-proteinase (HC-Pro) eliminate potato virus X/potyviral synergism. *Virology* 231:35-42.
35. Shukla, D. D., C. W., Ward., A. A., Brunt. 1994. *The Potyviridae*. CAB International, University Press, Cambridge, UK.
36. Tu, J. C., Ford, R. E., and Quiniones, S. S. 1969. Effect of Soybean mosaic virus and/or Bean pod mottle virus Infection on Soybean Nodulation. *Phytopathology* 60:518-523.
37. Untiveros, M., Fuentes, S., and Salazar, L. F. 2007. Synergistic interaction of *Sweet potato chlorotic stunt virus* (Crinivirus) with carla-, cucumo-, ipomo-, and potyviruses infecting sweet potato. *Plant Dis.* 91:669-676.
38. Urcuqui-Inchima, S., Haenni, A. L., and Bernardi, F. 2001. Potyvirus proteins: a wealth of functions. *Virus Res.* 74:157-175.
39. Van Regenmortel, M. H. V., Fauquet, C. M., Bishop, D. H. L., Carstens, E. B., Estes, M. K., Lemon, S. M., Maniloff, J., Mayo, M. A., McGeoch, D. J., Pringle, C. R., and Wickner, R. B. 2000. Virus taxonomy: The classification and nomenclature of viruses Page 1167 in: *The seventh report of the international committee on taxonomy of viruses. Virus Taxonomy, VIIth report of the ICTV.* Academic Press, San Diego.
40. Vance, V. B., Berger, P. H., Carrington, J. C., Hunt, A. G., and Shi, X. M. 1995. 5'-Proximal Potyviral Sequences Mediate Potato-Virus-X Potyviral Synergistic Disease in Transgenic Tobacco. *Virology* 206:583-590.
41. Vance, V.B. 1991. Replication of potato virus X RNA is altered in coinfections with potato virus Y. *Virology* 182: 486-494.

42. Venette, R. C., and Ragsdale, D. W. 2004. Assessing the invasion by soybean aphid (Homoptera : Aphididae): Where will it end? *Ann. Entomol. Soc. Am.* 97:219-226.
43. Voinnet, O., Pinto, Y. M., and Baulcombe, D. C. 1999. Suppression of gene silencing: A general strategy used by diverse DNA and RNA viruses of plants. *Proc. Natl. Acad. Sci. USA.* 96:14147-14152.
44. Wang, L., Eggenberger, A., Hill, J., and Bogdanove, A. J. 2006. *Pseudomonas syringae* effector *avrB* confers soybean cultivar-specific avirulence on *Soybean mosaic virus* adapted for transgene expression but effector *avrPto* does not. *Mol. Plant-Microbe Interact.* 19:304-312.
45. Wang, R. Y., and Ghabrial, S. A. 2002. Effect of aphid behavior on efficiency of transmission of Soybean mosaic virus by the soybean-colonizing aphid, *Aphis glycines*. *Plant Dis.* 86:1260-1264.
46. Wang, Y., Lee, K. C., Gaba, V., Wong, S. M., Palukaitis, P., and Gal-On, A. 2004. Breakage of resistance to *Cucumber mosaic virus* by co-infection with *Zucchini yellow mosaic virus*: enhancement of CMV accumulation independent of symptom expression. *Arch. Virol.* 149:379-396.
47. Zhang, C. Q., and Ghabrial, S. A. 2006. Development of *Bean pod mottle virus*-based vectors for stable protein expression and sequence-specific virus-induced gene silencing in soybean. *Virology* 344:401-411.

### Appendix 3: Tables

**Table 3.1.** Inoculation treatments of soybean cv. Williams 82; plants were inoculated singly or doubly with infectious sap containing SMV-N and AMV-JD or purified virions of viruses in a simultaneous or sequential inoculation formats

<i>Treatments</i>	<i>Time 1</i>	<i>Interval</i> ( <i>Hours</i> )	<i>Time 2</i>
1	AMV	4	Mock
2	SMV+AMV	Si <sup>1</sup>	-----
3	SMV	4	AMV
4	AMV	4	SMV
5	SMV	4	Mock

<sup>1</sup>= Si : Simultaneous Inoculation

**Table 3.2.** Antigen coated indirect ELISA analysis of accumulation of AMV-JD (A) and SMV-N (B) in soybean cv. Williams 82 in single- or double-inoculations (simultaneously or sequentially)

**A**

<i>Treatment Comparison</i>	<i>Time</i> <sup>1</sup>	<i>Time</i> <sup>2</sup>	<i>Absorbance value for AMV</i> <sup>1</sup>	<i>AMV ratio Dual/Single</i>
1	AMV	Mock	0.11 ± 0.02 b	2.8
	SMV+AMV	Si <sup>2</sup>	0.31 ± 0.02 a	
2	AMV	Mock	0.11 ± 0.02 b	3.5
	SMV	AMV	0.39 ± 0.02 a	
3	AMV	Mock	0.11 ± 0.02 b	3.4
	AMV	SMV	0.37 ± 0.02 a	

**B**

<i>Treatment Comparison</i>	<i>Time</i> <sup>1</sup>	<i>Time</i> <sup>2</sup>	<i>Absorbance value for SMV</i> <sup>1</sup>	<i>SMV ratio Dual/Single</i>
1	SMV	Mock	0.55 ± 0.14 a	0.7
	SMV+AMV	Si <sup>2</sup>	0.40 ± 0.14 b	
2	SMV	Mock	0.55 ± 0.14 a	0.7
	SMV	AMV	0.40 ± 0.14 b	
3	SMV	Mock	0.55 ± 0.14 a	0.8
	AMV	SMV	0.45 ± 0.14 a	

<sup>1</sup> Indirect ELISA absorbance values at 405 nm for the dilution 1:10 (wt/vol) of extracts obtained from a middle trifoliolate of each trifoliolate. Values are least square means ± SE from a total of six replicate plants; data from two experiments were pooled for analysis. For each pair of treatment means, values followed by the same letter are not significantly different according to an F-protected LSD at  $P=0.05$ .

<sup>2</sup> Si: Simultaneous inoculation.

**Table 3.3.** Antigen coated indirect ELISA analysis of accumulation of different isolates of AMV (**A**) and SMV strain N (**B**) coat proteins from ‘Williams 82’ in single or double inoculations

**A**

<i>Treatment Comparison</i>	<i>Viruses</i>	<i>Replicate plants</i>	<i>Absorbance value for AMV<sup>1</sup></i>	<i>AMV ratio Dual/Single</i>
1	AMV-JD	6	0.58 ± 0.18 b	1.3
	AMV-JD + SMV-N	6	0.74 ± 0.18 a	
2	AMV-Ch	10	0.38 ± 0.14 b	1.6
	AMV-Ch + SMV-N	10	0.6 ± 0.14 a	
3	AMV-S0118	8	0.22 ± 0.02 b	2.1
	AMV-S0118 + SMV-N	8	0.46 ± 0.02 a	
3.1	AMV-S0118	7	0.94 ± 0.35 a	1.3
	AMV-S0118 + SMV-N	7	1.2 ± 0.35a	

**B**

<i>Treatment Comparison</i>	<i>Viruses</i>	<i>Replicate plants</i>	<i>Absorbance value for SMV<sup>1</sup></i>	<i>SMV ratio Dual/Single</i>
1	SMV-N	6	0.71 ± 0.1 a	0.8
	AMV-JD + SMV-N	6	0.57 ± 0.1 b	
2	SMV-N	10	0.85 ± 0.05 a	0.8
	AMV-Ch + SMV-N	10	0.67 ± 0.05 b	
3	SMV-N	8	1.18 ± 0.08 a	0.9
	AMV-S0118 + SMV-N	8	0.93 ± 0.08 b	
3.1	SMV-N	7	1.23 ± 0.11 a	0
	AMV-S0118 + SMV-N	7	0.0 ± 0.12 b	

<sup>1</sup> Indirect ELISA absorbance values at 405 nm for the dilution 1:10 (wt/vol) of extracts obtained from a middle trifoliolate leaf at 21 and 30 dpi. Unifoliolate leaves were inoculated with 10 µg/plant purified virions of AMV isolates, SMV- N, or a mixture of 20 µg/plant purified virions of AMV and SMV (10 µg each/plant) for mixed infection. Values are least square means ± SE; data from two experiments were pooled for analysis. For each pair of treatment means, values followed by the same letter are not significantly different according to an F-protected LSD at  $P=0.05$ .

**Table 3.4.** Antigen coated indirect ELISA analysis of accumulation of different isolates of AMV (**A**) and SMV strain G7 (**B**) coat proteins from ‘Williams 82’ in single- or double-inoculations

**A**

<i>Treatment Comparison</i>	<i>Viruses</i>	<i>Absorbance value for AMV<sup>1</sup></i>	<i>AMV ratio Dual/Single</i>
1	AMV-JD	1.5 ± 0.14 b	
	AMV-JD + SMV-G7	1.9 ± 0.11 a	1.3
2	AMV-Ch	1.16 ± 0.14 b	
	AMV-Ch + SMV-G7	1.7 ± 0.1 a	1.5
3	AMV-S0118	0.82 ± 0.2 a	
	AMV-S0118 + SMV-G7	1.08 ± 0.16 a	1.3

**B**

<i>Treatment Comparison</i>	<i>Viruses</i>	<i>Absorbance value for SMV<sup>1</sup></i>	<i>SMV ratio Dual/Single</i>
1	SMV-G7	0.89 ± 0.07 a	
	AMV-JD + SMV-G7	0.7 ± 0.07 a	0.8
2	SMV-G7	0.89 ± 0.07 a	
	AMV-Ch + SMV-G7	0.54 ± 0.1 b	0.6
3	SMV-G7	0.89 ± 0.07 a	
	AMV-S0118 + SMV-G7	0.33 ± 0.08 b	0.4

<sup>1</sup> Indirect ELISA absorbance values at 405 nm for the dilution 1:10 (wt/vol) of extracts obtained from one disc of each trifoliolate per trifoliolate leaf 21 days post inoculation. Unifoliolate leaves were inoculated with 10 µg/plant purified virions of AMV isolates, SMV-G7, or a mixture of 20 µg/plant purified virions of AMV and SMV (10 µg each/plant) for mixed infection. Values are least square means ± SE from a total of six replicate plants; data from two experiments was pooled for analysis. For each pair of treatment means, values followed by the same letter are not significantly different according to an F-protected LSD at *P*=0.05.

**Table 3.5.** Antigen coated indirect ELISA analysis of accumulation of different isolates of AMV (A) and SMV strain N (B) coat proteins from ‘Lee 68’ in single- or double-inoculation

**A**

<i>Treatment Comparison</i>	<i>Viruses</i>	<i>Replicate plant</i>	<i>Absorbance value for AMV<sup>1</sup></i>	<i>AMV ratio Dual/Single</i>
1	AMV-JD	9	0.89 ± 0.1b	2
	AMV-JD + SMV-N	10	1.81 ± 0.8 a	
2	AMV-Ch	9	0.41 ± 0.13 b	2.4
	AMV-Ch + SMV-N	10	0.97 ± 0.13 a	
3	AMV-S0118	8	0.33 ± 0.1 a	1.4
	AMV-S0118 + SMV-N	9	0.46 ± 0.09a	

**B**

<i>Treatment Comparison</i>	<i>Viruses</i>	<i>Replicate plant</i>	<i>Absorbance value for SMV<sup>1</sup></i>	<i>SMV ratio Dual/Single</i>
1	SMV-N	9	1.54 ± 0.1 a	1.1
	AMV-JD + SMV-N	10	1.63 ± 0.1 a	
2	SMV-N	9	1.55 ± 0.13 a	0.9
	AMV-Ch + SMV-N	10	1.43 ± 0.12 a	
3	SMV-N	9	1.56 ± 0.15 a	0.2
	AMV-S0118 + SMV-N	9	0.28 ± 0.15 b	

<sup>1</sup> Indirect ELISA absorbance values at 405 nm for the dilution 1:10 (wt/vol) of extracts obtained from one disc of each trifoliolate per trifoliolate leaf 21 days post inoculation. Unifoliolate leaves were inoculated with 10 µg/plant purified virions of AMV isolates, SMV- N, or a mixture of 20 µg/plant purified virions of AMV and SMV (10 µg each/plant) for mixed infection. Values are least square means ± SE; data from two experiments was pooled for analysis. For each pair of treatment means, values followed by the same letter are not significantly different according to an F-protected LSD at  $P=0.05$ .

**Table 3.6.** Antigen coated indirect ELISA analysis of accumulation of AMV-S0118 (A) and SMV-N (B) coat proteins from ‘Lee 68’ and ‘Williams 82’ in single- or double inoculations

**A**

<i>Treatment Comparison</i>	<i>Soybean cultivar</i>	<i>Viruses</i>	<i>Absorbance value for AMV<sup>1</sup></i>	<i>AMV ratio Dual/Single</i>
1	Williams 82	AMV-S0118	1.65 ± 0.1b	
		AMV-S0118 + SMV-N	2.1 ± 0.1 a	1.3
2	Lee 68	AMV-S0118	1.4 ± 0.14 a	
		AMV-S0118 + SMV-N	1.7 ± 0.13 a	1.2

**B**

<i>Treatment Comparison</i>	<i>Soybean cultivar</i>	<i>Viruses</i>	<i>Absorbance value for SMV<sup>1</sup></i>	<i>SMV ratio Dual/Single</i>
1	Williams 82	SMV-N	1.30 ± 0.15 a	
		AMV-S0118 + SMV-N	0.45 ± 0.15 b	0.3
2	Lee 68	SMV-N	2.3 ± 0.22 a	
		AMV-S0118 + SMV-N	0.44 ± 0.22 b	0.2

<sup>1</sup> Indirect ELISA absorbance values at 405 nm for the dilution 1:10 (wt/vol) of extracts obtained from the middle trifoliolate of each trifoliolate leaf 21 days post inoculation. Unifoliolate leaves were inoculated with 10 µg/plant purified virions of AMV-S0118, SMV- N, or a mixture of 20 µg/plant purified virions of AMV and SMV (10 µg each/plant) for mixed infection. Values are least square means from a total of 10 replicate plants ± SE. For each pair of treatment means, values followed by the same letter are not significantly different according to an F-protected LSD at *P*=0.05.

### Appendix 3: Figures

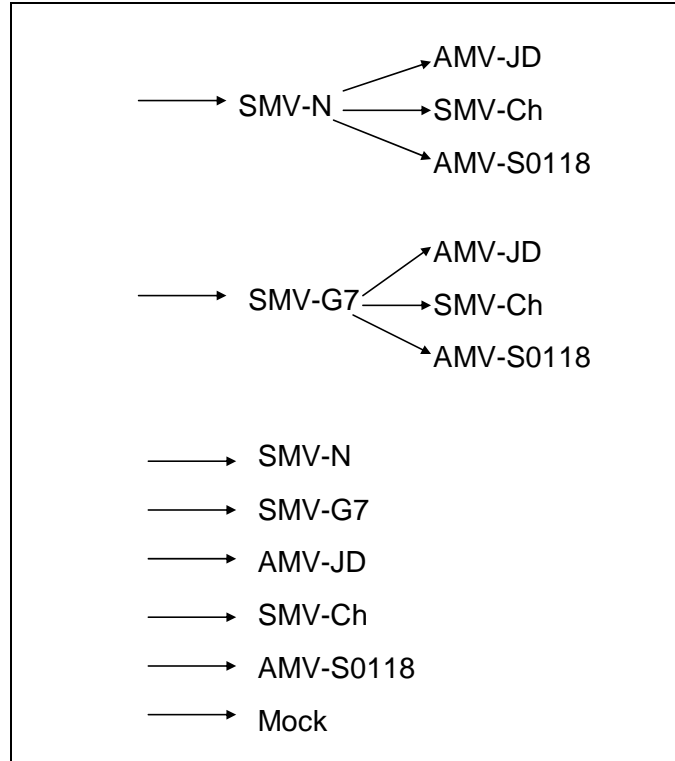
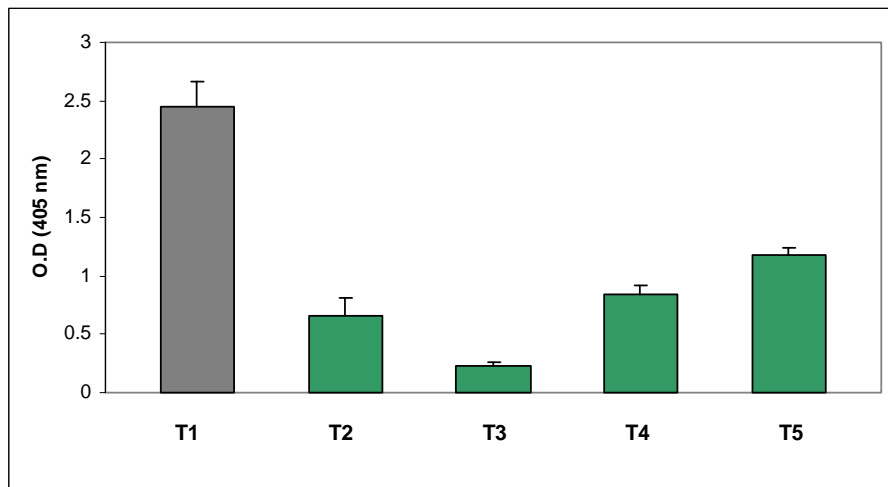

**Figure 3.1.** Experimental design (virus combinations) of soybean plants cvs. Williams 82 and Lee 68 in single or mixed-inoculation with SMV strains and AMV isolates in a simultaneous inoculation format.

**A**



**B**



**Figure 3.2.** Phenotypic response of ‘Williams 82’ to inoculation with infectious sap containing AMV-JD (**A**), and analysis of AMV-JD coat protein (CP) accumulation by antigen coated indirect ELISA  $\pm$  SE (**B**). Following inoculation, the plants were maintained in a growth chamber (25 °C) until trifoliates 1- 4 (T1-T4) from a representative plant was photographed 21 days post-inoculation. Samples from corresponding trifoliolate leaflets 1-5 (T1-T5) of four replicate plants were combined. Sap was extracted at 1/10 (wt/vol) and CP was detected using a polyclonal antibody against AMV CP (**B**).



**Figure 3.3.** Phenotypic response of ‘Williams 82’ to inoculation with 10 µg/plant purified virions of SMV-N. Following inoculation, the plants were maintained in a growth chamber (25°C) until trifoliolate 3 (T3) from two representative plants were photographed 30 days post-inoculation.

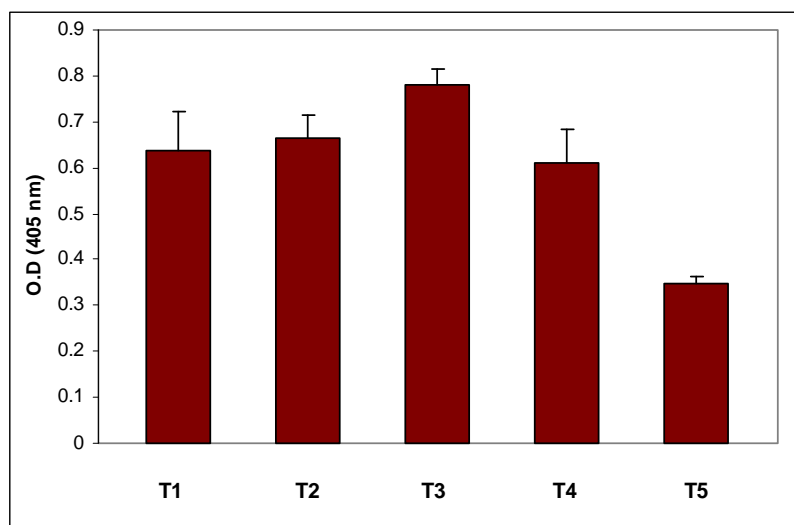

**Figure 3.4.** Antigen coated indirect ELISA analysis of accumulation of SMV-N Coat Protein (CP) in ‘Williams 82’ trifoliolate leaves  $\pm$  SE. Primary leaves were mechanically inoculated with 10 µg/plant purified virions of SMV-N. Following inoculation, the plants were maintained in a growth chamber (25°C) until a middle trifoliolate from trifoliates 1-5 (T1-T5) of infected plants was collected 30 days post-inoculation. Samples from corresponding trifoliolates of four replicate plants were combined. Sap was extracted at 1/10 (wt/vol) and CP was detected using a polyclonal antibody against SMV CP.

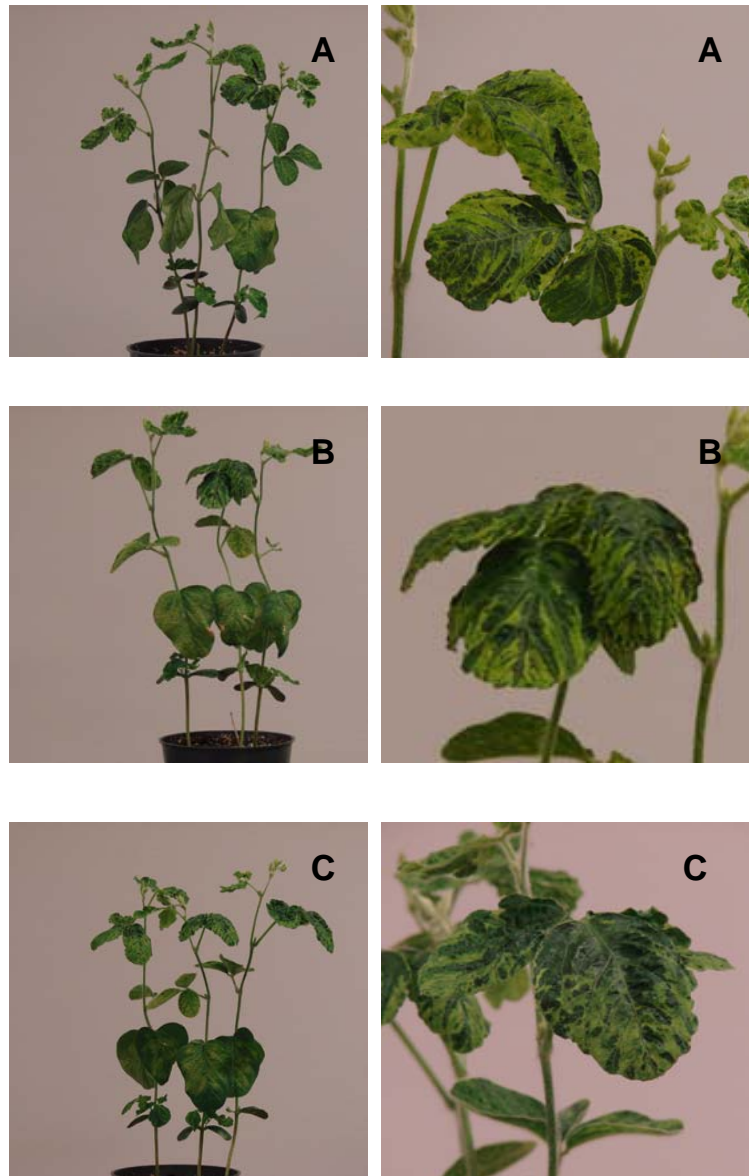

**Figure 3.5.** Phenotypic differences in response of ‘Williams 82’ to inoculation with infectious sap containing AMV-JD and SMV-N using simultaneous (A), delayed inoculation, AMV-JD first and SMV-N second (B), and delayed inoculation, SMV-N first and AMV-JD second (C). Following inoculation, the plants were maintained in a growth chamber (25°C) until photographed 21 days post-inoculation. Note plants shown to the right side are a close up of the plants shown to the left side.

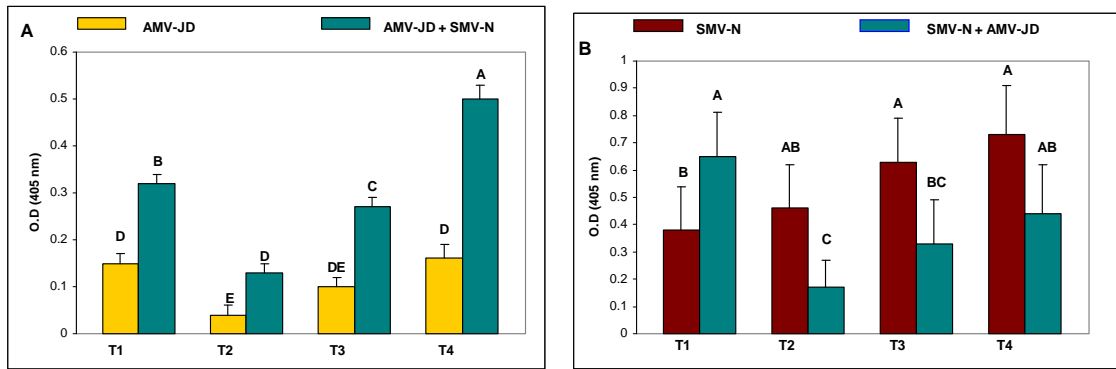

**Figure 3.6.** Antigen coated indirect ELISA analysis of accumulation of AMV-JD (**A**) and SMV-N (**B**) coat protein (CP) in ‘Williams 82’ trifoliolate leaves. Primary leaves were mechanically inoculated with 10 µg/plant purified virions of AMV-JD, a mixture of 20 µg/plant of AMV-JD and SMV-N (10 µg each/plant) and SMV-N 10 µg/plant (**C**) simultaneously. Following inoculation, the plants were maintained in a growth chamber (25°C) until a middle trifoliolate from trifoliolate leaves 1-4 (T1 to T4) of infected plants was collected 21 and 30 days post-inoculation. Samples from corresponding trifoliolates of three replicate plants for each time point were combined; sap extracted at 1/10 (wt/vol), clarified by a brief centrifugation, and CP was detected using a polyclonal antibody against AMV CP (**A**) or SMV CP (**B**). Bars are least square means ± SE from a total of six replicate plants; data from two experiments was pooled for analysis. For each pair of treatment means, bars with the same letter are not significantly different according to an F-protected LSD at  $P=0.05$ .

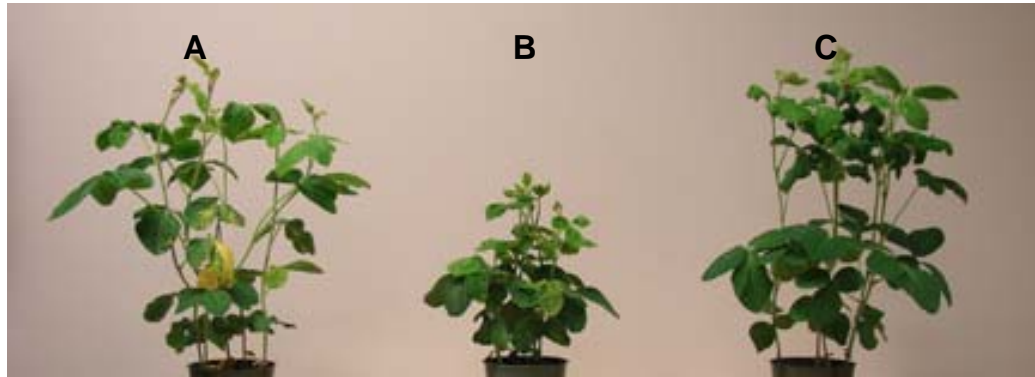

**Figure 3.7.** Phenotypic differences in response of soybean cv. Williams 82 to inoculation with 10  $\mu\text{g}/\text{plant}$  purified virions of AMV-JD (**A**), a mixture of 20  $\mu\text{g}/\text{plant}$  of AMV-JD and SMV-N (10  $\mu\text{g}$  each/plant) (**B**) and SMV-N 10  $\mu\text{g}/\text{plant}$  (**C**). Following inoculation, the plants were maintained in a growth chamber (25°C) until photographed 21 days post-inoculation. Note the severe stunting in (**B**).

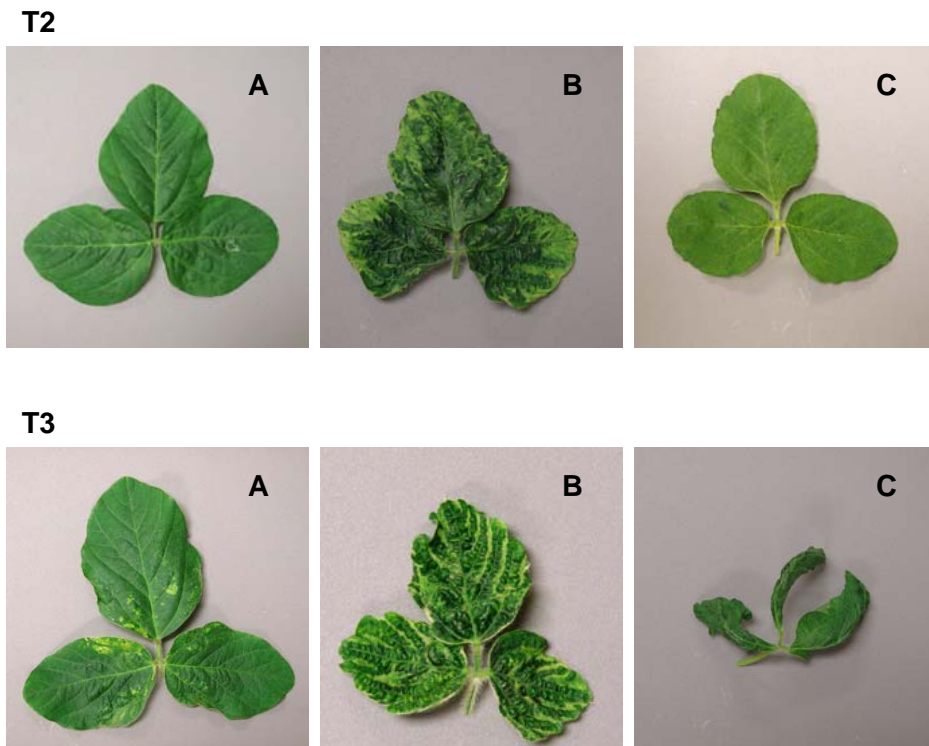

**Figure 3.8.** Phenotypic differences in response of ‘Williams 82’ to inoculation with infectious sap containing AMV-JD (**A**), a mixture of sap containing both AMV-JD and SMV-N (**B**) and SMV-N (**C**). Following inoculation, the plants were maintained in a growth chamber (25°C) until representative trifoliates 2 (T2) and 3 (T3) were photographed 21 days post-inoculation. Note the severe deformation and mosaic in (**B**).

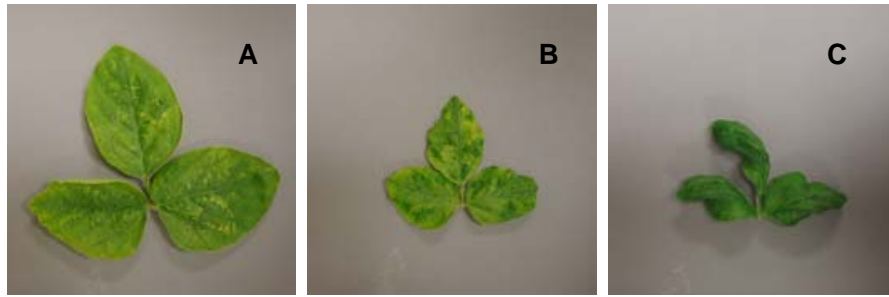

**Figure 3.9.** Phenotypic differences in response of ‘Williams 82’ to inoculation with 10  $\mu\text{g}/\text{plant}$  purified virions of AMV-S0118 (**A**), a mixture of 20  $\mu\text{g}/\text{plant}$  of AMV- S0118 and SMV-N (10  $\mu\text{g}$  each/plant) (**B**) and SMV-N (10  $\mu\text{g}/\text{plant}$ ) (**C**). Following inoculation, the plants were maintained in a growth chamber (25°C) until a representative trifoliate 3 from one infected plant was photographed 21 days post-inoculation. Note the different pattern of symptoms in (**B**).

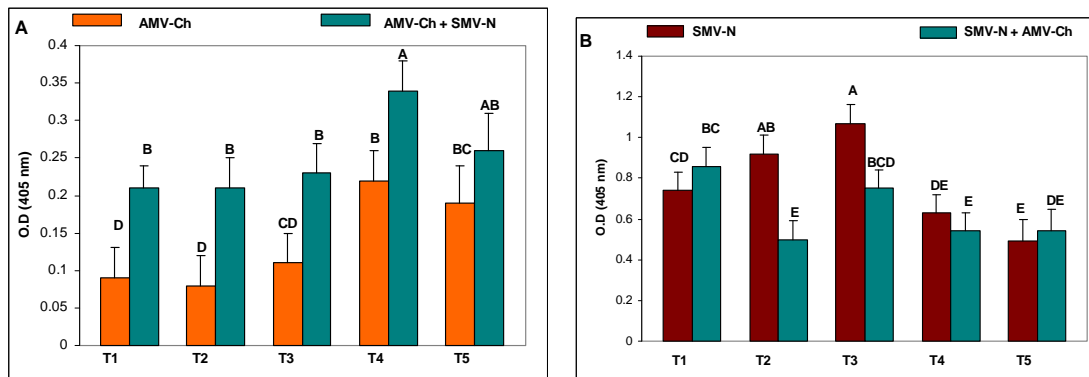

**Figure 3.10.** Antigen coated indirect ELISA analysis of accumulation of AMV-Ch (A) and SMV-N (B) coat protein (CP) in ‘Williams 82’ leaves. Unifoliate leaves were mechanically inoculated with 10 µg/plant purified virions of AMV Ch, SMV- N, or a mixture of 20 µg/plant purified virions of AMV-Ch and SMV- N (10 µg each/plant). Following inoculation, the plants were maintained in a growth chamber (25°C) until a middle trifoliolate from trifoliolate leaves 1-5 (T1 to T5) from each inoculated plant was collected 21 and 30 days post-inoculation. Samples from corresponding trifoliolate leaves of four replicate plants for each time point were combined; sap was extracted at 1/10 (wt/vol) and CP was detected using a polyclonal antibody against AMV CP (A) and SMV CP (B). Bars are least square means ± SE from a total of eight replicate plants; data from two experiments were pooled for analysis. For each pair of treatment means, bars with the same letter are not significantly different according to an F-protected LSD at  $P=0.05$ .

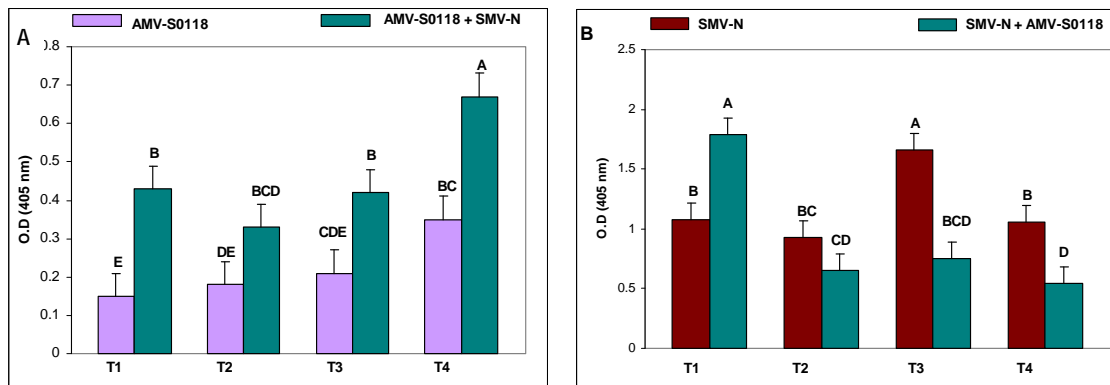

**Figure 3.11.** Antigen coated indirect ELISA analysis of accumulation of AMV-S0118 (**A**) and SMV-N (**B**) coat protein (CP) in ‘Williams 82’ leaves. Unifoliate leaves were mechanically inoculated with 10 µg/plant purified virions of AMV S0118, SMV- N, or a mixture of 20 µg/plant purified virions of AMV-S0118 and SMV-N (10 µg each/plant). Following inoculation, plants were maintained in a growth chamber (25°C) until a middle trifoliolate from trifoliolate leaves 1-4 (T1 to T4) from infected plants were collected 21 and 30 days post-inoculation. Samples from corresponding trifoliolate leaves of four replicate plants for each time point were combined; sap was extracted at 1/10 (wt/vol) and CP was detected using a polyclonal antibody against AMV CP (**A**) and SMV CP (**B**). Bars are least square means ± SE from a total of eight replicate plants; data from two experiments were pooled for analysis. For each pair of treatment means, bars with the same letter are not significantly different according to an F-protected LSD at  $P=0.05$ .

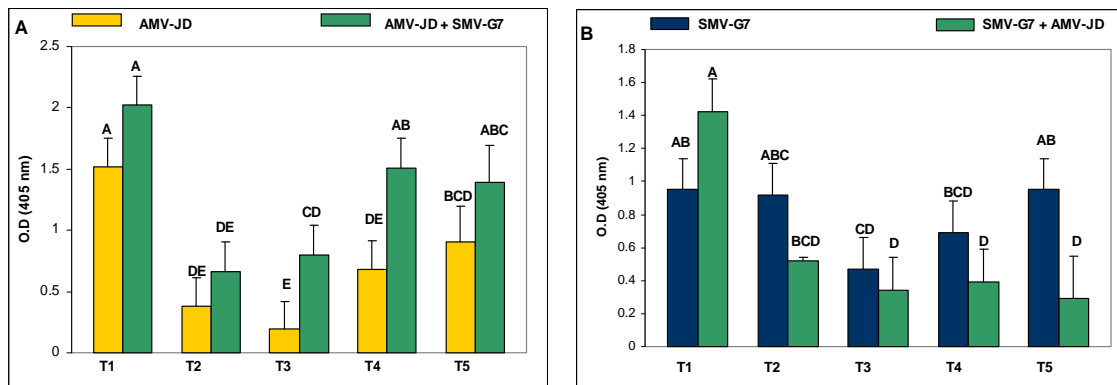

**Figure 3.12.** Phenotypic differences in response of soybean cv. Williams 82 to inoculation with 10  $\mu\text{g}/\text{plant}$  purified virions of AMV-JD (**A**), a mixture of 20  $\mu\text{g}/\text{plant}$  of AMV-JD and SMV-G7 (10  $\mu\text{g}$  each/plant) (**B**) and SMV-G7 10  $\mu\text{g}/\text{plant}$  (**C**). Following inoculation, the plants were maintained in a growth chamber (25°C) until photographed 21 days post-inoculation. Note the severe stunting in (**B**).

**T3**



**Figure 3.13.** Phenotypic differences in response of Williams 82 to inoculation with 10  $\mu\text{g}/\text{plant}$  purified virions of AMV-JD (**A**), a mixture of 20  $\mu\text{g}/\text{plant}$  of AMV-JD and SMV-G7 (10  $\mu\text{g}$  each/plant) (**B**) and SMV-G7 (10  $\mu\text{g}/\text{plant}$ ) (**C**). Following inoculation, the plants were maintained in a growth chamber (25°C) until a representative trifoliate 3 (T3) from one infected plant was photographed 21 days post-inoculation. Note the severity of symptoms in (**B**).



**Figure 3.14.** Antigen coated indirect ELISA analysis of accumulation of AMV-JD (**A**) and SMV-G7 (**B**) coat protein (CP) in single and dual infection. Primary leaves of Williams 82 were mechanically inoculated with infectious sap containing virions of AMV-JD, SMV-G7, or a mixture of the two viruses. Inoculum consisted of sap from infected soybean tissues (1:10 w/v) after clarification by a brief centrifugation for 10 min. After inoculation, the plants were maintained in a growth chamber (25°C) until a middle trifoliolate from each trifoliolate leaves 1-5 (T1 to T5) of infected plants were collected 21 and 30 days post-inoculation. Samples from corresponding trifoliolate leaves of three replicate plants for each time point were combined; sap was extracted at 1/10 (wt/vol) and CP was detected using a polyclonal antibody against AMV CP (**A**) or SMV CP (**B**). Bars are least square means  $\pm$  SE from a total of six replicate plants; data from two experiments was pooled for analysis. For each pair of treatment means, bars with the same letter are not significantly different according to an F-protected LSD at  $P=0.05$ .

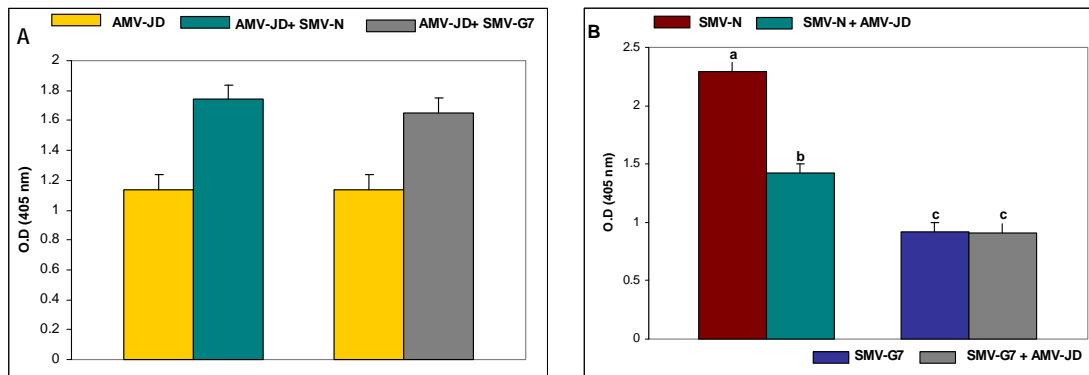

**Figure 3.15.** Antigen coated indirect ELISA analysis of accumulation of AMV-JD (A), SMV-N (B) and SMV-G7 (B) coat proteins (CP) in single or dual infection of ‘Williams 82’. Primary leaves were mechanically inoculated with 10 µg/plant purified virions of AMV JD, SMV- N, SMV-G7 or a mixture of 20 µg/plant purified virions of AMV-JD and each of SMV strains (10 µg each/plant). Following inoculation, the plants were maintained in a growth chamber (25°C) until one disc per trifoliolate from trifoliolate leaves 1-4 of infected plants was collected 21 days post-inoculation. Discs from corresponding trifoliolate leaves of fifteen replicate plants were combined; sap was extracted at 1/10 (wt/vol) and CP was detected using a polyclonal antibody against AMV CP (A) or SMV CP (B). Bars are least square means ± SE from a total of fifteen replicate plants. For each pair of treatment means, bars with the same letter are not significantly different according to an F-protected LSD at  $P=0.05$ .

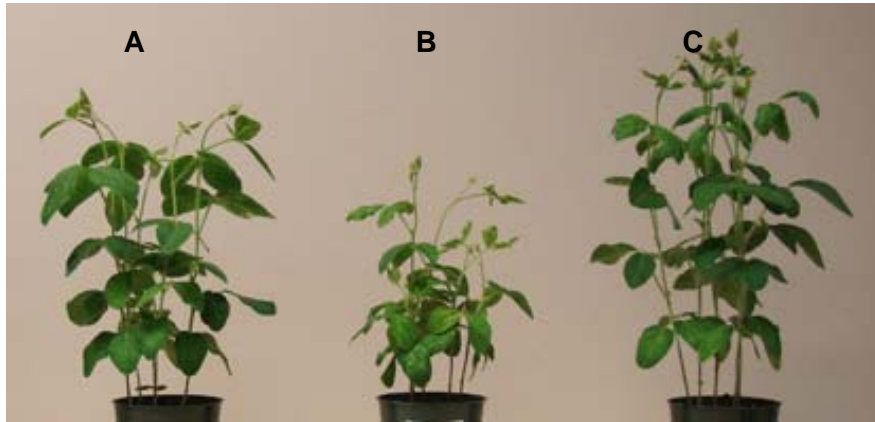

**Figure 3.16.** Phenotypic differences in response of soybean cv. Lee 68 to inoculation with 10 µg/plant purified virions of AMV-JD (**A**), a mixture of 20 µg/plant of purified AMV-JD and SMV-N (10 µg each/plant) (**B**) and SMV-N (10 µg/plant) (**C**). Following inoculation, the plants were maintained in a growth chamber (25°C) until photographed 21 days post-inoculation. Note the severe stunting in (**B**).



**Figure 3.17.** Phenotypic differences in response of soybean cv. Lee 68 to inoculation with purified virions of AMV-Ch (10µg/plant) (**A**), a mixture of 20 µg/plant of AMV- Ch and SMV-N (10 µg each/plant) (**B**) and SMV-N (10 µg/plant) (**C**). Following inoculation, the plants were maintained in a growth chamber (25°C) until photographed 21 days post-inoculation. Note the severe stunting in (**B**).



**Figure 3.18.** Phenotypic differences in response of soybean cv. Lee 68 to inoculation with purified virions of AMV-Ch (10  $\mu\text{g}/\text{plant}$ ) (A), a mixture of 20  $\mu\text{g}/\text{plant}$  of AMV- Ch and SMV-G7 (10  $\mu\text{g}$  each/plant) (B) and SMV-G7 (10  $\mu\text{g}/\text{plant}$ ) (C). Following inoculation, the plants were maintained in a growth chamber (25°C) until photographed 21 days-post inoculation. Note the severe stunting in (B).



**Figure 3.19.** Phenotypic differences in response of ‘Lee 68’ to inoculation with purified virions of AMV-S0118 (10  $\mu\text{g}/\text{plant}$ ) (A), a mixture of 20  $\mu\text{g}/\text{plant}$  of AMV-S0118 and SMV-N (10  $\mu\text{g}$  each/plant) (B) and SMV-N (10  $\mu\text{g}/\text{plant}$ ) (C). Following inoculation, the plants were maintained in a growth chamber (25°C) until a representative trifoliate 3 from each of the inoculations was photographed 21 days post-inoculation. Note the severe stunting in (B).

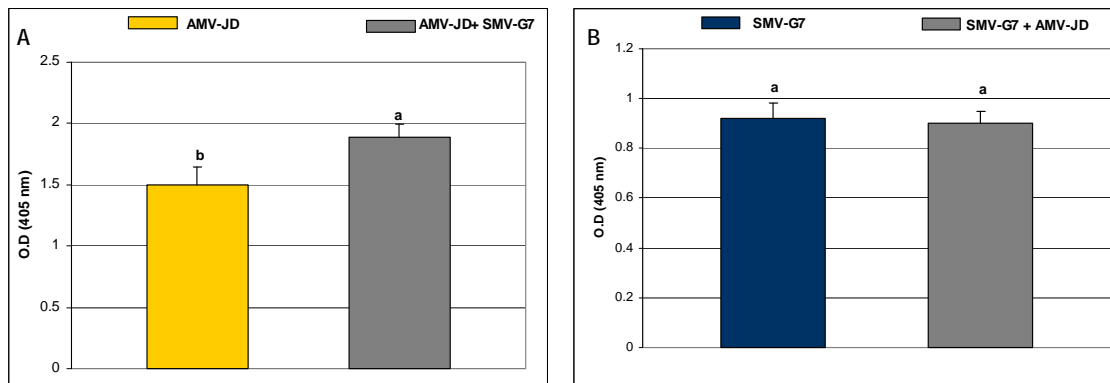

**Figure 3.20.** Antigen coated indirect ELISA analysis of accumulation of AMV-JD (A) and SMV-G7 (B) coat protein (CP) in ‘Lee 68’ plants. Unifoliate leaves were mechanically inoculated with 10 µg/plant purified virions of AMV JD, SMV- G7, or a mixture of 20 µg/plant purified virions of AMV and SMV(10 µg each/plant). Following inoculation, the plants were maintained in a growth chamber (25°C) until one disc per trifoliolate from trifoliolate 1-4 of infected plants was collected 21 days post-inoculation. Discs from corresponding trifoliolate leaves of ten replicate plants were combined; sap was extracted at 1/10 (wt/vol) and CP was detected using a polyclonal antibody against AMV CP (A) and SMV CP (B). Bars are least square means ± SE from a total of ten replicate plants; data from two experiments was pooled for analysis. For each pair of treatment means, bars with the same letter are not significantly different according to an F-protected LSD at  $P=0.05$ .

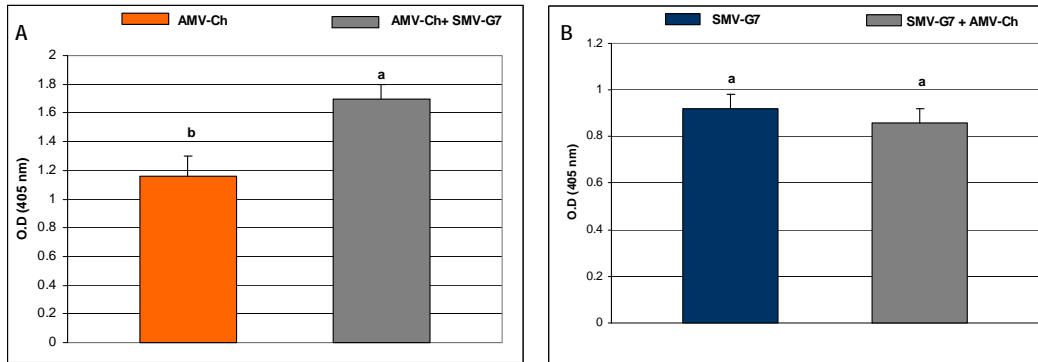

**Figure 3.21.** Antigen coated indirect ELISA analysis of accumulation of AMV-Ch (**A**) and SMV-G7 (**B**) coat protein (CP) in ‘Lee 68’ plants. Unifoliolate leaves were mechanically inoculated with 10 µg/plant purified virions of AMV Ch, 10 µg/plant of SMV- G7, or a mixture of 20 µg/plant purified virions of AMV and SMV(10 µg each/plant). Following inoculation, the plants were maintained in a growth chamber (25°C) until one disc per trifoliolate from trifoliolate leaves 1-4 of infected plants was collected 21 days post-inoculation. Discs from corresponding trifoliolate leaves of four replicate plants were combined; sap was extracted at 1/10 (wt/vol) and CP was detected using a polyclonal antibody against AMV CP (**A**) and SMV CP (**B**). Bars are least square means ± SE from a total of eight replicate plants; data from two experiments was pooled for analysis. For each pair of treatment means, bars with the same letter are not significantly different according to an F-protected LSD at  $P=0.05$ .

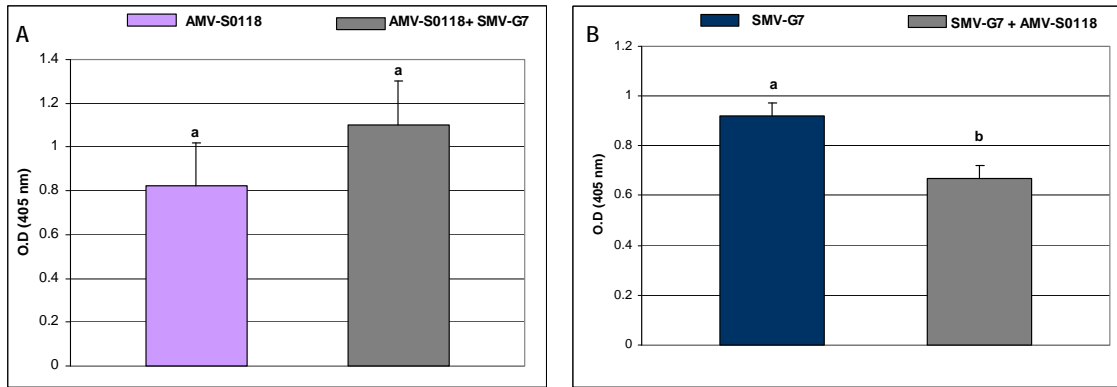

**Figure 3.22.** Antigen coated indirect ELISA analysis of accumulation of AMV-S0118 (**A**) and SMV-G7 (**B**) coat proteins (CP) in 'Lee 68'. Unifoliate leaves were mechanically inoculated with 10  $\mu\text{g}/\text{plant}$  purified virions of AMV S0118, 10  $\mu\text{g}/\text{plant}$  of SMV- G7, or a mixture of 20  $\mu\text{g}/\text{plant}$  purified virions of AMV and SMV (10  $\mu\text{g}$  each/plant). Following inoculation, the plants were maintained in a growth chamber (25°C) until one disc per trifoliolate from trifoliolate 1-4 of infected plants was collected 21 days post-inoculation. Discs from corresponding trifoliolate leaves of four replicate plants were combined; sap was extracted at 1/10 (wt/vol) and CP was detected using a polyclonal antibody against AMV CP (**A**) and SMV CP (**B**). Bars are least square means  $\pm$  SE from a total of eight replicate plants; data from two experiments was pooled for analysis. For each pair of treatment means, bars with the same letter are not significantly different according to an F-protected LSD at  $P=0.05$ .

## Vita

Martha Malapi-Nelson was born in Lima, Peru, in 1981. She finished her bachelor degree in Agronomy at “La Universidad Nacional Agraria. She was introduced to plant pathogens during her summer field work and decided that she wanted to know more.

In 2004, she received training for a period of three months at the International Potato Center (CIP), which is a member of the Consultative Group on International Agricultural Research (CGIAR). Afterwards, she received a scholarship and continued working at CIP for eighteen months in the Immunodiagnostic and Molecular Virology Laboratory, under the supervision of Dr. Luis Salazar.

In 2006 she began her graduate studies with Dr. Reza Hajimorad at The University of Tennessee, where she enjoyed working in a Plant Virology Laboratory for two and a half years.

Upon graduation, Martha will begin her study toward a Ph.D. at Texas A&M University in a Program directed at Biology of Filamentous Fungi in the Micotoxicology Laboratory.