

The University of Tennessee

# Rural School Wastewater Treatment System



*authors*

Parker Dulin Payton Smith James Swart

*mentor*

Dr. John Buchanan

## Acknowledgements

The Rural School Wastewater Treatment Senior Design team would like to thank the following people for their assistance and guidance. Without the continual support and help from the department and the following individuals, we would not have been able to develop this project to the degree in which we did.

We would like to thank our Biosystems Engineering Apprentice students, Cabot Anderson, Topher Keller, Luke Martin, Patrick Rimer, and Taylor Spivey, for their hard work and interest in our project. They cooperated to design and build a sturdy and visually appealing stand for our lab scale sequencing batch reactor and impressed us with their enthusiasm and knowledge of AutoCAD.

We would also like to thank Dr. John Buchanan, our senior design mentor. He kept us on track, encouraged us to be innovative thinkers, and lent us the use of his laboratory and equipment.

Special thanks to:

*Dr. Paul Ayers    Brittani Perez    David Smith    Scott Tucker    Dr. Daniel Yoder*

*Wesley Wright*

## **Abstract**

Homes and businesses located in rural areas depend upon on-site or near-site treatment for wastewater management. Most rural, residential locations implement septic systems that utilize the soil to provide wastewater treatment and healthy dispersal of water back into the environment. Larger facilities, such as rural schools, often generate more wastewater than can be treated by the soils, thus requiring an on-site wastewater treatment plant and permit establishing parameters for the discharge. Generally speaking, these plants are poorly supervised and are often in violation of their discharge permit – especially with regard to the ammonia concentration. The goal of the Rural School Wastewater Treatment System is to provide a means of wastewater treatment that can measure nitrogen concentrations and effectively provide the conditions necessary for nitrogen removal. The proposed treatment system would be composed of a septic tank, sequencing, moving bed, batch reactor (SBBR), and UV disinfection. A laboratory scale model with a treatable volume of 13 gallons has been constructed and preliminary testing has occurred. A programmable controller and various sensors have been installed to monitor the reduction and oxidation processes required to remove nitrogen from wastewater. After inoculating the reactor with biomass from the Knoxville Utilities Board (KUB), the system experienced approximately 30% removal of ammonia and nearly 100% removal of E. coli. With continuous operation of the system, removal rates are expected to improve as the colonies of necessary heterotrophic and autotrophic bacteria continue to grow.

Keywords: wastewater, nitrogen, ammonia, nitrate, ammonification, nitrification, denitrification, bacteria, sequencing batch reactor, flow equalization tank, septic tank

# Table of Contents

Abstract .....	3
1.0 Introduction .....	5
2.0 Background .....	6
2.1 Wastewater Treatment .....	6
2.2 NPDES Permits.....	7
3.0 Project Needs.....	8
4.0 Project Goals .....	8
5.0 Project Objectives .....	9
6.0 Justification of Selected Design Approach .....	9
6.1 Primary Treatment .....	9
6.2 Secondary Treatment .....	10
6.3 Tertiary Treatment .....	14
7.0 Nitrogen Removal .....	15
8.0 Theoretical Full Scale System Design .....	18
9.0 Lab Scale System .....	22
9.1 Lab Scale Components .....	22
9.2 Lab Scale System Sizing and Justification .....	23
10.0 Integrated Control Design.....	33
10.1 Hardware.....	33
10.2 Software .....	39
11.0 Results.....	<b>Error! Bookmark not defined.</b>
12.0 Conclusion.....	<b>Error! Bookmark not defined.</b>
12.2 Budget .....	46
13.0 Recommendations .....	<b>Error! Bookmark not defined.</b>
References .....	48
Appendix.....	50
A.1 Drawings .....	50
A.2 Morph Charts for Justification of Choices .....	54
A.3 Pump Curves .....	55
A.4 Disinfection Curve .....	56
A.5 Calibration Curves .....	56
A.6 Instrumentation and Controls.....	58
A.7 Biosystems 104 Student Apprentice Contribution.....	79

## 1.0 Introduction

Controlling the treatment and management of wastewater has been of great concern to civilizations for thousands of years. Wastewater treatment is critical in preventing waterborne diseases from causing damage to both ecological and human health (Center for Sustainable Systems, 2014). The beginning of wastewater treatment practices date as far back as 1,500 B.C. with the construction of the city Mohenjo-Daro, located in present day Pakistan (Wiesmann, Choi, and Dombrowski, 2007). Although this treatment practice can be traced back early civilization, wastewater treatment has only been a major industry in the United States since the 1800s (Macalester College, n.d.). In the 1850's, the U.S. built its first municipal sewer system in Chicago, Illinois. During this time period, it was still a commonly accepted practice to discharge wastewater directly into streams without treatment. In fact, the importance of wastewater treatment was not fully recognized until the late 1800s. Since then, there has been a steady progression of wastewater treatment technologies (Macalester College, n.d.).

The progression of wastewater engineering led to the creation and implementation of important laws. Around the turn of the 20<sup>th</sup> century, the United States' government started recognizing the significance of wastewater treatment. The Federal Water Pollution Control Act of 1948, enacted by congress, laid the groundwork for more stringent discharge regulations. The act was later amended in 1972 and became known as the Clean Water Act. This act in particular provided the funding necessary to construct sewage treatment plants across the country (EPA, 2015).

Pressure from urbanization and stricter regulations led to an immense amount of development and implementation of wastewater control during the mid-1900s. Over the past 65 years, innovative treatment methods and technologies have been developed, extending the realm of wastewater treatment further than metropolitan areas (Burian, et al., 2000). Although wastewater treatment can be implemented in numerous different ways, the process operates under a basic pattern of steps, including: primary, secondary, and tertiary treatment. These steps all include critical timing and flow rates

that are essential to being able to adequately treat wastewater. Heavy operational maintenance and full time staff are a requirement in larger facilities.

## **2.0 Background**

### **2.1 Wastewater Treatment**

Wastewater treatment is a multiple step process that typically includes primary treatment, secondary treatment, and tertiary treatment. Primary treatment initiates wastewater treatment. This primary treatment induces the settling of suspended solids. Suspended solids refer mostly to fecal matter, but also include sediment and other solid, sinkable particles. Depending on the system, this includes environmental debris, as well as fats, oils, and grease (FOG). As the wastewater flows through primary treatment, heavy particles will settle to the bottom as “sludge” (The World Bank Group, 2015). Depending on the method, primary treatment has the potential to lessen the biochemical oxygen demand (BOD), an indirect measurement of organic material present in the water, from 25 to 50% and the total suspended solids concentration from 50 to 70% (Natural Resources Management and Environment Department, n.d.).

Secondary treatment is a stage of chemical and biological significance. This stage is critical for the removal of nutrient concentrations. Removal of biodegradable dissolved and colloidal organic matter are fundamental to this process, as well as the transformation of nitrogen from an environmentally harmful form to an environmentally inert form (Natural Resources Management and Environment Department, n.d.). Both processes are facilitated by aerobic and anaerobic microbes that degrade organic material and nitrogenous compounds. Together, secondary and primary treatments typically remove 85% of the BOD from the original effluent (The World Bank Group, 2015).

Tertiary treatment is typically the last step before the wastewater is discharged. Prior to this step, most of the nutrients and organic matter have been removed, but it allows for the effluent to approach drinking water quality and is typically characterized by a disinfection technique (The World Bank Group, 2015). This process is commonly done

with chlorine, which is required to be removed before discharge. Other sources of treatment can come from ozone or ultraviolet radiation treatment (Natural Resources Management and Environment Department, n.d.). Once this process is complete, the wastewater is allowed to be discharged.

## 2.2 NPDES Permits

National Pollutant Discharge Elimination System or NPDES permits are a requirement established by the aforementioned Clean Water Act. NPDES permits were set in place to regulate point discharge into surface water from industrial, municipal, and other facilities (EPA, 2015). There are two overall types of permits: general permits and individual permits. General permits regulate a geographical region to categorize their discharge standards, most construction sites and industrial sites are under the standards of general permits. Individual permits set the standard for individual facilities that have a unique design. Figure 1 shows an NPDES permit with the contaminants being monitored, as well as the allowable levels in the effluent.

PERMITTEE NAME ADDRESS (01-04) (05-06) (07-08) (09-10) (11-12) (13-14) (15-16) (17-18) (19-20) (21-22) (23-24) (25-26) (27-28) (29-30) (31-32) (33-34) (35-36) (37-38) (39-40) (41-42) (43-44) (45-46) (47-48) (49-50) (51-52) (53-54) (55-56) (57-58) (59-60) (61-62) (63-64) (65-66) (67-68) (69-70) (71-72) (73-74) (75-76) (77-78) (79-80) (81-82) (83-84) (85-86) (87-88) (89-90) (91-92) (93-94) (95-96) (97-98) (99-00)

**NATIONAL POLLUTANT DISCHARGE ELIMINATION SYSTEM (NPDES) DISCHARGE MONITORING REPORT (DMR)**

EPAS2-329 PERMIT NUMBER 001 DISCHARGE NUMBER

MONITORING PERIOD

From 2001 07 01 To 2001 07 31

Check here if No Discharge

NOTE: Read instructions before completing this form.

PARAMETER (02-37)		QUANTITY OR LOADING (04-51)			QUALITY OR CONCENTRATION (06-53)			NO. EX (62-63)	FREQUENCY OF ANALYSIS (64-68)	SAMPLE TYPE (69-70)	
		AVERAGE	MAXIMUM	UNITS	MINIMUM	AVERAGE	MAXIMUM				UNITS
71-55-6 1,1,1-Trichloroethane (Methyl chloroform)	SAMPLE MEASUREMENT					3.146000	4.630000	G/L	1	5 / 30	GRAB
	PERMIT REQUIREMENT	N/A	N/A	N/A	N/A	2.000000	4.000000	G/L		DAY	GRAB
7439-92-1 Lead	SAMPLE MEASUREMENT					19.228333	28.400000	MG/L	0	6 / 30	GRAB
	PERMIT REQUIREMENT	N/A	N/A	N/A	N/A	20.000000	30.000000	MG/L		WEEK	GRAB
PH pH Balance	SAMPLE MEASUREMENT				6.730000		8.030000	N/A	0	6 / 30	24HOUR
	PERMIT REQUIREMENT	N/A	N/A	N/A	6.000000	N/A	9.500000	N/A		SWEEK	24HOUR
SUSPEND Total suspended solids	SAMPLE MEASUREMENT					8.256667	10.900000	G/L	0	3 / 30	GRAB
	PERMIT REQUIREMENT	N/A	N/A	N/A	N/A	5.000000	12.000000	G/L		WEEK	GRAB
TEMP Temperature in Deg. Celcius	SAMPLE MEASUREMENT	25.028571	27.400000	C					0	7 / 30	24HOUR
	PERMIT REQUIREMENT	25.000000	30.000000	C	N/A	N/A	N/A	N/A		SWEEK	24HOUR
AMMONIA Ammonia Nitrogen (as N)	SAMPLE MEASUREMENT	5.278333		LB		0.830500	1.230000	MG/L	0	6 / 30	24HOUR
	PERMIT REQUIREMENT	6.000000	N/A	LB	N/A	0.500000	2.000000	MG/L		SWEEK	24HOUR

Figure 1. A sample NPDES Permit for A.V. Systems, Inc. in Ann Arbor, MI (A V Systems, Inc., 2008).

### **3.0 Project Needs**

When constructing a new building with restroom facilities, wastewater management must be addressed to ensure compliance with governmental regulations. Unfortunately, sites not located within the domain of public sewers must exploit other means to handle wastewater. Such locations commonly implement septic systems to treat the wastewater. Traditional septic systems employ the usage of a septic tank for primary treatment and an absorption field for biochemical treatment. However, a rural school is currently being constructed in a location where the depth of soil is shallow. With the distance from the soil surface to the bedrock layer being short, a septic field is not an applicable method for higher-level treatment. For septic fields to be successful, suitable soil must be present to act as a natural sponge, absorbing contaminants and nutrients. Therefore, the design proposed must employ other mechanistic means of contaminant removal. Furthermore, the system must be capable of handling inconsistent influent, as well as operating with minimal amounts of supervision. Since the flow is coming from a school, the levels of ammonia present in the influent will be higher than those in a typical municipal wastewater treatment system. Consequently, the system will require programmable controls and sensors that determine necessary conditions during the treatment process. Most importantly, the treatment system needs to be competent at contaminant and nutrient removal to the degree established by the site's National Pollutant Discharge Elimination System Permit.

### **4.0 Project Goals**

- Develop treatment system that can be implemented at any location discharging into an open water source
- Construct integrated control system that monitors the treatment process while logging data concerning contaminant concentration levels
- Design for longevity
- Design system with a minimal footprint
- Design for minimal environmental impact

## 5.0 Project Objectives

- Design theoretical wastewater treatment system capable of handling flow generated by a school population of 700 occupants
- Develop and construct a lab-scale model capable of producing effluent with contaminant concentration levels that satisfies Coalfield School's NPDES permit
- Design system that requires minimal supervision
- Construct and design integrated control system that recognizes when to pump the wastewater or other necessary reactants to facilitate the treatment process
- Construct integrated control system that can measure nitrogen concentrations as low as 1 mg/L

## 6.0 Justification of Selected Design Approach

### 6.1 Primary Treatment

Once wastewater has been treated for solids in primary treatment, it moves on to secondary treatment. Secondary treatment is critical to achieving a wastewater effluent free of ecologically harmful forms of nitrogen, as well as dissolved and colloidal

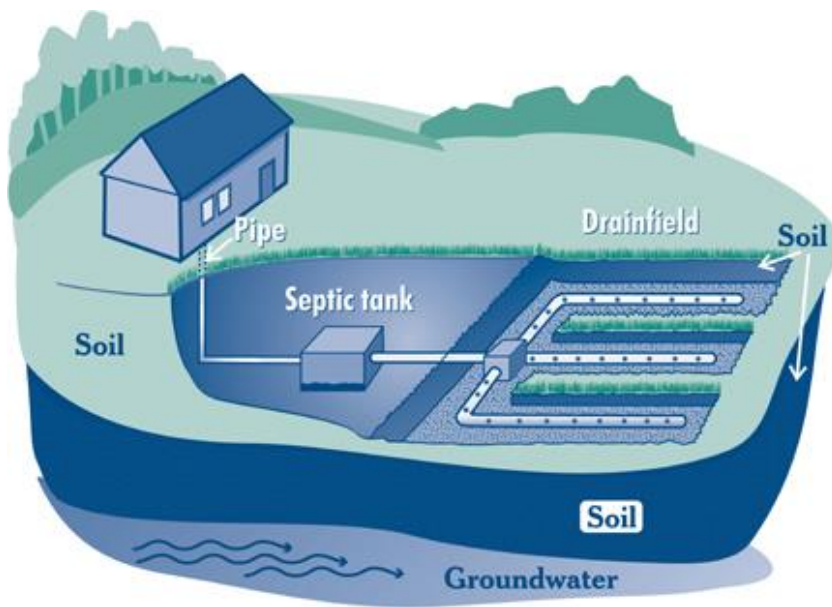

Figure 2. Traditional septic systems include both a septic tank and drain field (International Association of Certified Home Inspectors , 2016).

compounds. In a typical septic system, primary treatment occurs in the septic tank, and then the effluent discharges into a septic field, where the physical, chemical, and biological properties of the soil treat the wastewater for remaining contaminants (EPA, 2012). Unfortunately, due to the school's geographic location, the soil

depth does not extend deep enough for an absorption field to be an effective means of higher-level treatment. Therefore, a traditional septic system, as depicted in Figure 2, cannot be implemented in its entirety.

However, septic tanks, by themselves, still provide an effective means of primary treatment. Therefore, our design will incorporate a septic tank for primary treatment, followed by an alternative form of secondary treatment that does not rely on soil filtration.

## 6.2 Secondary Treatment

In the realm of wastewater management, a plethora of methodologies and mechanisms exist to conduct secondary treatment. These mechanical treatment methods can be separated into two broad categories: suspended growth and attached growth.

Suspended growth involves the free flow of wastewater in a large tank. The treatment comes from suspended

microorganisms in the wastewater agitated by an air pump. Settlement in the system causes bacteria to be retained for future treatments. In contrast, the attached growth method models natural movement

of water in a soil profile (NESC 2004). The

wastewater passes through a fixed media bed, composed of a non-toxic material on which bio-films form. As the wastewater interacts with the bio-films, the bacteria treat the wastewater (Westerling 2014). Under the umbrella of these two main categories, the membrane bioreactor, trickling filter, and sequencing batch reactor were considered as viable options. The mechanism of initial interest was the membrane bioreactor (MBR). Membrane bioreactors use the practice of suspended growth. MBRs have a

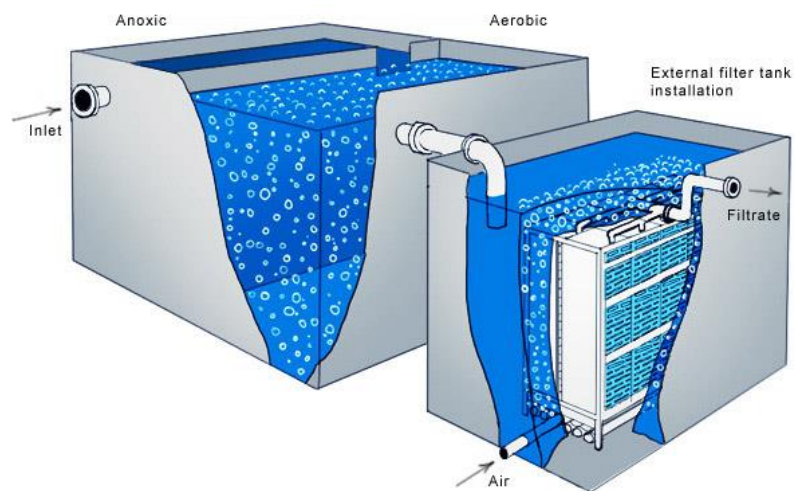

Figure 3. Example of a membrane bioreactor (ATAC Solutions Ltd, 2014).

minimal footprint compared to other typical suspended growth systems. Lately, there has been an increase in use of membrane filtration in larger systems; however, the membrane was originally designed for use in small flow systems (EPA 2007). An advantage to this system is its capability of receiving influent with high contaminant concentrations. The membrane, which gives this system its name, acts as a filter for contaminants. Having the added filter system ensures that the high load of pollutants is removed. Unfortunately, the initial and operational cost is high when compared to other treatment methods. Although the fabrication price is lowering, there is still a high cost associated with pumping for aeration, maintenance, and the inevitable replacement of the membrane (Chapman, Leslie and Law). Since the membrane bioreactor would not be economically feasible, trickling filtration was the next treatment method considered. The trickling filter method is the most common type of attached growth system. Attached growth media can be gravel, peat moss, ceramic, plastic, or textile media, as long as the media is conducive for growth and non-toxic to microbes. As water trickles down through the system, contaminants are degraded by the attached communities of microorganisms growing on the media. Various advantages and disadvantages exist relating to this type of system. A strong advantage for this system is the low operating cost. Trickling filters do not employ the use of a large energy-intensive blower; the system is aerated by the gravitational movement of the water through the filters. The overall footprint of the system is not large, making trickling filters ideal for sites dealing with size constraints (EPA 2000). Yet, costs associated with construction, maintenance, and recirculation of the water would prove to be excessive. Furthermore, trickling filters cannot handle large, instantaneous fluxes, making them inapplicable to systems that experience flow inconsistencies (NESC 2004). Furthermore, one common issue associated with continuous flow systems relates to recirculation; if a certain volume of water continues to have a high level of pollutants at the conclusion of the treatment process, it must be recirculated through the system. As more water requires recirculation, an accumulation of water can occur, eventually leading to the overflow of the system. Pairing a continuous system with variable influent flow rates and concentrations is simply an illogical application. A trickling filter can be seen on the next page in Figure 4.

## Trickling Filter

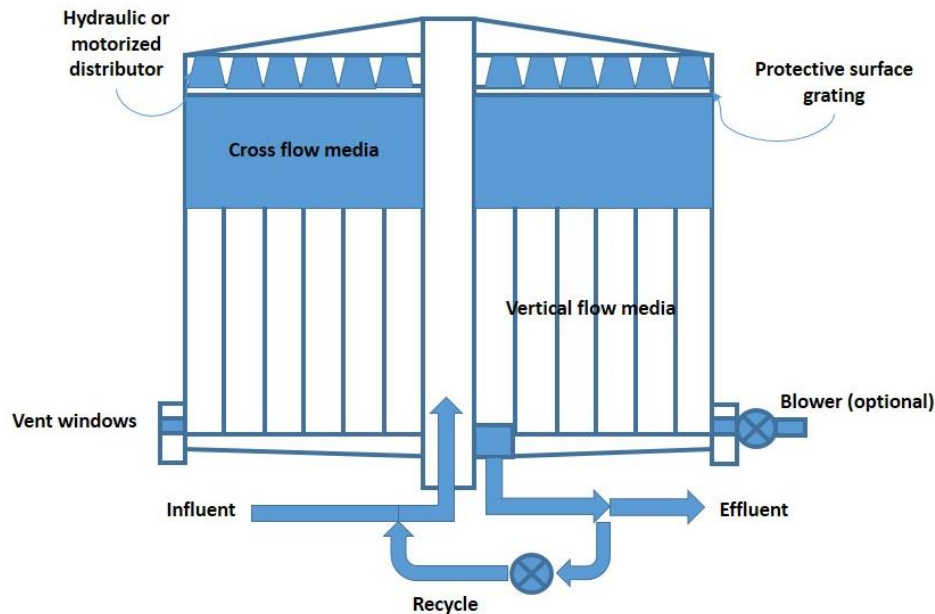

Figure 4. Example of a trickling filter system (The Asian Development Bank, 2011).

Finally, the last treatment method considered was the sequencing batch reactor (SBR). Sequencing batch reactors are a specific type of suspended growth that uses a batch method and only one chamber to treat the wastewater. A requirement for this system is a large amount of electronic instrumentation and control. Sequencing batch reactors perform well at filtering out nutrients and have a small footprint, which is ideal for a rural school. The biggest advantage when using a SBR is the immense amount of control over the final product. Since this system will be paired with a high level of controls and automation, the system can start and end when necessary without the involvement of an operator. The need for intricate electronic controls makes the construction of this system more complicated and expensive, yet it increases flexibility and reduces the need for operator attention (EPA 1999d).

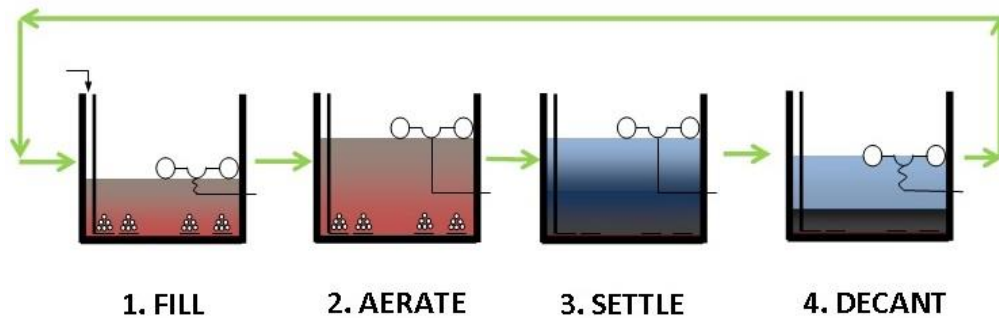

Figure 5. Treatment process of a Sequencing Batch Reactor (WAPP).

The treatment process followed by a Sequencing Batch Reactor can be seen in Figure 5. Based on the applicability to the given situation, the sequencing batch reactor method will be employed as the means of secondary treatment.

Using the SBR method alone is useful, but it is also important to consider methods of making this technology even better for the specific application. Wastewater treatment is highly dependent on available surface area. One method of increasing the system's internal surface area is use of Integrated Moving Bed Biofilm Reactor Technology (MBBR). These porous suspended media help to increase surface area for the denitrifying bacteria to grow on, reducing the footprint of the system. Also, by increasing microbial activity, the wastewater will not need to experience as long of a treatment time, decreasing the time of use of the money intensive aerator (HeadworksBIO 2015). This technology will be a useful addition to the SBR system in order to increase production while keeping the footprint small. An image of the MBBR's used in the system can be seen in Figure 6.



Figure 6. Moving Bed Biofilm Reactor that will be used in the SBR (Amazon, 2016).

### 6.3 Tertiary Treatment

Based on the surrounding county's NPDES permit, the water must also be disinfected prior to discharge. Thus, the next area of analysis for the system was the method of tertiary treatment. The EPA recommends several disinfection techniques for effluent being directly discharged to surface water. The most common methods include: chlorination, ozone, and ultraviolet light. Each of these methods has different advantages and disadvantages.

Chlorination is the most common method of disinfection for wastewater treatment plants, both on a large and small scale. It has been proven to be extremely effective at removing bacteria and pathogens. Chlorination has also proven to be the most cost effective method of disinfection used on wastewater; however, this cost does not include the cost of dechlorinating the water, which is necessary prior to discharge since chlorine is harmful to aquatic life (EPA 1999a).

The second method of disinfection that was considered was disinfection by ozone. Ozone has proven to be more effective than chlorine at removing pathogens, viruses, and bacteria. In addition, this method requires a short 10 to 30 minutes of contact time for disinfection. Since ozone decomposes quickly after treatment, it does not need to be removed from the wastewater prior to discharge (EPA 1999b). Ozone generation for disinfection can be done on site, but the process proves to be expensive and is only economically feasible for large treatment facilities.

The final method of disinfection considered was treatment by ultraviolet (UV) light. UV light is currently being used at many small wastewater treatment plants on school grounds in East Tennessee, such as Coalfield School in Morgan County. Unlike the use of chlorine or ozone, this method does not employ the use of hazardous chemicals. UV requires the shortest contact time of any current disinfection method, ranging from 20 to 30 seconds of contact with the lamp. UV has proven to be user friendly for operators and does not require any additional processes after disinfection prior to discharge. Unlike the other disinfection methods, if the water's turbidity is high, the method will not be effective (EPA 1999c).

After analyzing cost, ease of operation, and effectiveness, it was clear that UV disinfection would best serve the system. Since the schools will not have an operator on site, this system also requires the least amount of maintenance and would not require removal of any compound prior to discharge.

## 7.0 Nitrogen Removal

The SBR is vital to the system's operation since it is the site of nitrogen removal. In addition, this step in the treatment process will lead to a further reduction in BOD and other contaminants; however, the SBR will be operated with respect to nitrogen concentration and removal, considering nitrogen will require the most time and attention to remove. As wastewater flows through the sequencing batch reactor, nitrogenous compounds experience multiple reactions that ultimately lead to the production of nitrogen gas. Therefore, to fully comprehend the processes involved with the sequencing batch reactor, a strong understanding of nitrogen degradation must be established. In essence, the nitrogen cycle is composed of five steps: nitrogen fixation, nitrification, assimilation, ammonification, and denitrification (Environmental). However, wastewater entering the sequencing batch reactor will only be experiencing ammonification, nitrification, and denitrification. Throughout these steps, nitrogen is converted to numerous different forms, and knowing when these reactions take place, as well as the conditions best suited for them, is crucial to managing the nitrogen removal process. By means of the integrated control system, sensors determine the various concentrations of nitrogenous compounds present, and then incorporate the necessary reactants to facilitate the chemical reactions. By implementing an automated system capable of sensing required conditions will greatly reduce operator supervision and increase water quality. Currently, we believe the system will need 4 probes to aid in automation, including: ammonium, nitrate, dissolved oxygen, and pH.

During ammonification, waste compounds, such as proteins and uric acids, are converted into ammonia.

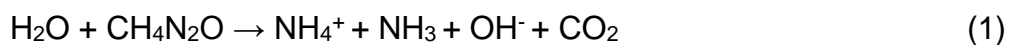

For example, urea,  $\text{CH}_4\text{N}_2\text{O}$ , reacts with water to generate ammonium ions, ammonia, hydroxide, and carbon dioxide. Since ammonification occurs in the absence of oxygen, wastewater is initially exposed to anaerobic conditions. During this conversion process, the ammonium concentration will be monitored through the ammonium sensor. To enforce quality control, the sensors will be coded to establish a standard deviation that will reduce the likelihood incorrect instrumentation.

Once complete conversion from urea to ammonia occurs, which typically occurs shortly after entering the SBR, nitrification takes place, converting ammonia into nitrite, which inevitably breaks down into nitrate. As seen in the successive chemical equations below, diatomic oxygen is required as a reagent. The dissolved oxygen probe will aid in gauging the transfer of air into the solution.

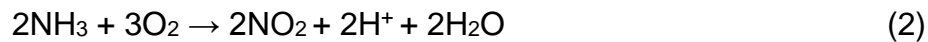

To induce this aerobic environment, an aerator will transfer air into the system that will be programmed to recognize the commencement of nitrification. Chemically speaking, the integrated controls must be closely monitoring not only the nitrate concentration, but also the pH of the solution. As seen in equation 2, the decomposition of ammonia leads to the production of hydronium ions, acidifying the solution. Unfortunately, various species of bacteria present in wastewater require a neutral environment to thrive. Thus, the pH probe is necessary to monitor the acidity of the environment and determine the correct amount of sodium bicarbonate ( $\text{NaHCO}_3$ ) needed to neutralize the water. If the pH starts to drop below 6, a calculated amount of  $\text{NaHCO}_3$  will be pumped into the SBR.

Finally, nitrate will undergo denitrification.

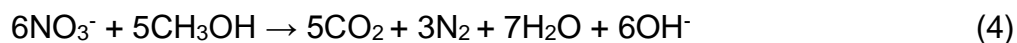

This final step in the conversion process requires anaerobic conditions. During this stage, a few hours are provided to allow the settling of suspended solids, as well as to

ensure the system enters an anaerobic state. This final step in the degradation of nitrogen is determined by the availability of a carbon source. Since this reaction is occurring at the end of the treatment process, main sources of organic material have either been settled or filtered out. Therefore, the system will be automated to recognize entry into the second stage of anaerobic conditions and determine the necessary amount of methanol to add based on the concentration of nitrate. Once the nitrogen is in a gaseous state, it escapes the solution and reenters the atmosphere (Water, 2012). The theoretical conversion trends between ammonium and nitrate are expected to follow the pattern seen below in figure 7.

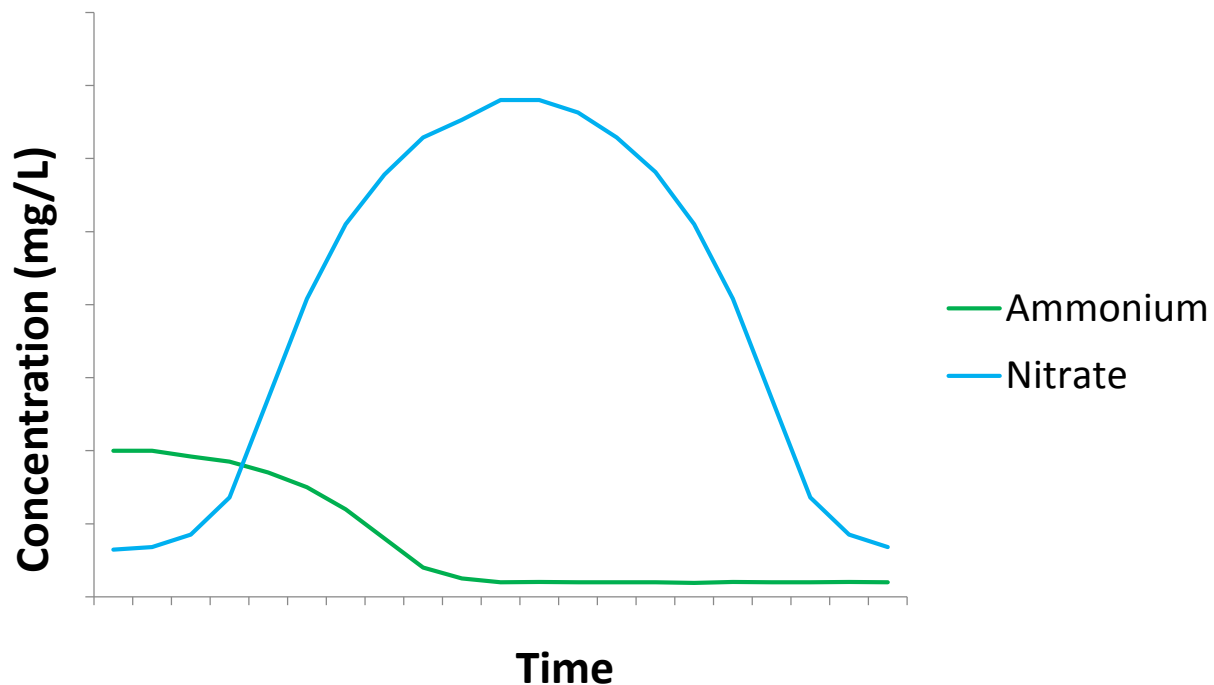

Figure 7. Displaying the relationship between ammonium and nitrate conversion.

The intersection between ammonium and nitrate is the definitive separation between ammonification and nitrification. Finally, as the concentration of nitrate levels off, denitrification takes place, converting nitrate into nitrogen gas.

Although this process merely appears to be a list of simple, successive chemical reactions, the treatment system gains complexity when considering the success of

these reactions is dependent on populations of microorganisms that thrive in different environmental conditions. As described previously, different nitrogen compounds are produced depending on whether the sequencing batch reactor is inducing aerobic or anaerobic conditions. Although the presence or absence of oxygen is a function of nitrogen degradation through the duration of the entire treatment process, understanding when to initiate anaerobic conditions is pivotal in the transition from nitrification to denitrification. Since the final stage of the treatment process utilizes facultative, heterotrophic bacteria, the organisms can thrive in either aerobic or anaerobic environments. By producing an anaerobic environment, the sequencing batch reactor is ensuring the heterotrophs are utilizing nitrate as their source of oxygen, stimulating the final step of nitrogen degradation and generating  $N_2$  gas (Weaver, 2003). Developing populations of these microorganisms is crucial to the system's ability to remove nitrogen.

## 8.0 Theoretical Full Scale System Design

Now that the reasoning behind our choice in secondary and tertiary systems has been expressed, a more holistic view of the system will be explained, as well as each step in the treatment process. Upon leaving the confines of the school building, the wastewater enters a septic tank. This well-established, effective form of primary treatment simply utilizes baffles and strategically placed pipes to physically separate the floatable fats, oils, grease, (FOG) and sinkable sludge from the water (Sun Plumbing 2015).

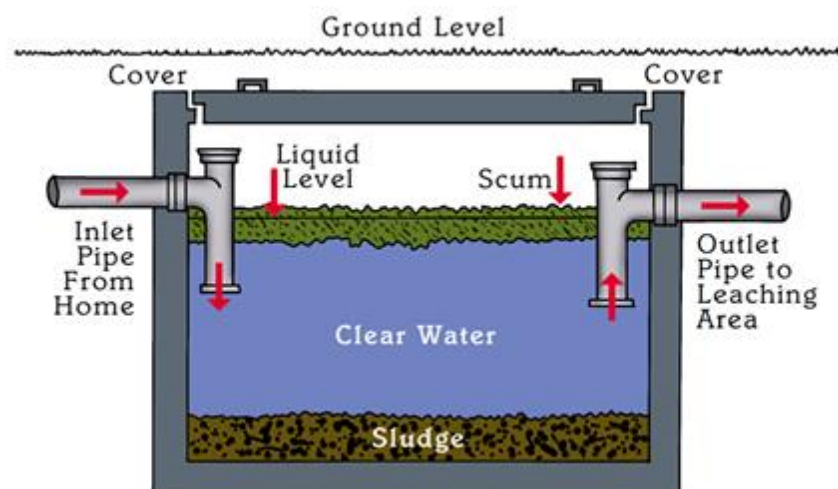

Figure 8. This visual depicts how a septic tank interacts with wastewater (Honey Bee Septic Service).

During this first stage in the treatment process, a dramatic decrease in BOD and TSS concentrations is expected. Research conducted through the Washington State Department of Health reveals that traditional, residential septic systems receive wastewater with BOD and TSS concentrations as high as 220 mg/L and 145 mg/L, respectively, and produce effluent with low concentrations ranges, from 100 to 140 mg/L for BOD and 20 to 55 mg/L for TSS (Washington). Although septic tanks induce high reduction of certain contaminants, they do not enable nitrogen removal or disinfection, revealing the necessity for secondary and tertiary treatment. However, it is worth noting that septic tanks stimulate anaerobic conditions, leading to an increased concentration of ammonia in the effluent. In raw wastewater, typically 70% of the nitrogen exists in the organic form and the remaining percentage exists as ammonium, yet, after experiencing anaerobic conditions in the tank, approximately 70 to 90% is expressed as ammonium and 10 to 30% appears as organic nitrogen in the septic effluent. Being aware of this chemical conversion is crucial to nitrogen removal in the subsequent steps.

Upon further review of the treatment system's organization and progression, one obvious disconnect becomes clear. A septic tank operates via a continuous process, generating effluent by displacement through the entrance of new wastewater in the tank, whereas a sequencing batch reactor conducts wastewater treatment via a batch process, meaning the systems cannot be readily positioned consecutively. Flow inconsistency is a common issue in wastewater treatment that is correctable through a flow equalization tank. By introducing another tank to the system, the treatment process will incidentally become more complicated and expensive; however, the introduction of this tank provides numerous benefits. For example, the tank will be equipped with a pump, providing more control concerning the volumetric size of the batch entering the reactor. Furthermore, without the presence of an equalization tank, either a pump or metering valve would need to be installed on the septic tank outlet, which could lead to obvious complications. If water was constantly being pumped out of the septic tank, its ability to separate FOG and sludge would be compromised by the agitation induced by the pump; in addition, metering the flow out of the septic tank could

cause clogging or overflow. The addition of this equalization tank will create a more seamless, controllable process. As mentioned previously, septic tanks encourage the conversion of organic nitrogen to ammonium –this process is defined as ammonification. Since ammonification is the first step in nitrogen degradation, this process will be encouraged between the septic and flow equalization tanks by inducing an anaerobic environment. Thus, upon entering the sequencing batch reactor, nearly all nitrogen should exist as ammonium. Finally, upon the completion of secondary treatment, the water will be pumped through the UV disinfection system. Each step in the treatment process is graphically outlined in Figure 9.

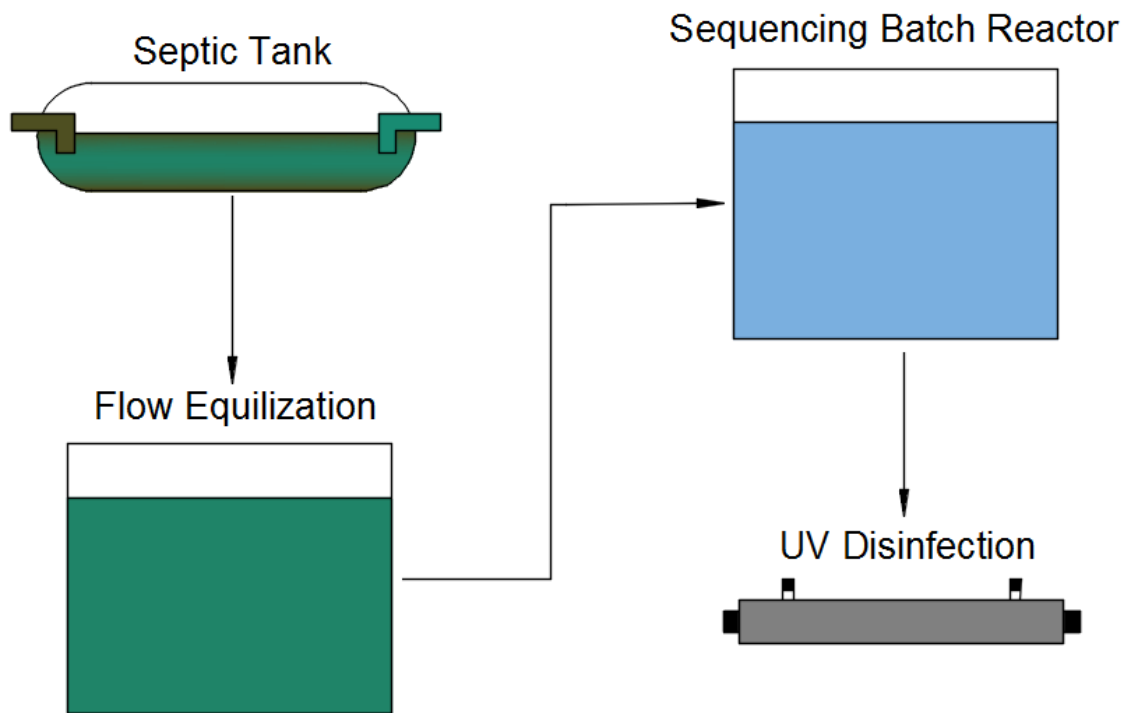

Figure 9. Overview of treatment process.

Sizing a wastewater treatment system is dependent on the amount of occupants a building is estimated to contain daily. The number of occupants this system will be sized for is 700 people. It is estimated that for a school with gyms, cafeterias, and showers each occupant will result in 25 gallons of waste flow per day. Combining the number of occupants and estimated waste per person will result in the value of 17,500 gal/day of waste effluent from the school (MDE, 2013).

Septic tank sizing is based on time requirements of the wastewater in the tank. According to the Alabama State Board of Health and Bureau of Environmental Services any given volume of wastewater in the tank needs to have a minimum hydraulic retention time of two days (48 hours) (ADPH, 2010). Therefore, the septic tank volume was calculated by multiplying the daily 17,500 gal/day inflow by 2. In addition, this number was sized up by 25% as a factor of safety.

Flow equalization tank sizing is based on current average daily flow and the peaking factor. The peaking factor is dependent on the design capacity range, which is 0 to 0.25 MGD for this system. For this range the peaking factor is 3. The average daily flow and the peaking factor are multiplied resulting in a value of approximately 56,104 gallons. Having a larger capacity than the average estimated flow will create extra space in the system in case an unexpectedly large amount of wastewater inflows into the system at any given time (MDE, 2013).

Sequencing batch reactor sizing is based on the number of batches required in one day and the amount of time it takes to treat each batch. The estimated time for a sequencing batch reactor to fully treat the wastewater is 4 to 6 hours (Toprak, 2006). The true residence time in the batch will vary and is dependent on the composition of the wastewater as it leaves the septic tank. It was decided that there would be four batches in a day (Dr. John Buchanan, University of Tennessee, personal communication, 7 December 2015). Taking the value of 17,500 gal/day of wastewater flow and dividing it by 4 for the number of batches per day and including a 25% factor of safety results in a 5,745 gallon volume for the SBR.

Table 1. Displaying representative sizes for actual treatment system.

<b>TANK SIZES</b>					
<b>System</b>	<b>Volume (gallons)</b>	<b>Volume (ft<sup>3</sup>)</b>	<b>Length (ft)</b>	<b>Width (ft)</b>	<b>Height (ft)</b>
Septic Tank	45,242	6,048	42	12	12
Flow Equalization Tank	56,104	7,500	25	25	12
Sequencing Batch Reactor	5,745	768	8	8	12

## 9.0 Lab Scale System

### 9.1 Lab Scale Components

- Lab Scale Flow Equalization Tank
- Flow Equalization Tank Decanter
- Flow Equalization Tank Float Sensor
- SBR Inflow Pump
- SBR Aeration Pump
- SBR Aeration Piping
- SBR High Float Sensor
- SBR Low Float Sensor
- Ammonium and Nitrate Sample Chamber Pump
- Dissolved Oxygen and pH Sample Chamber Pump
- Ammonium and Nitrate Sample Chamber
- Dissolved Oxygen and pH Sample Chamber
- SBR Decanter
- SBR Outflow Pump
- UV Disinfection

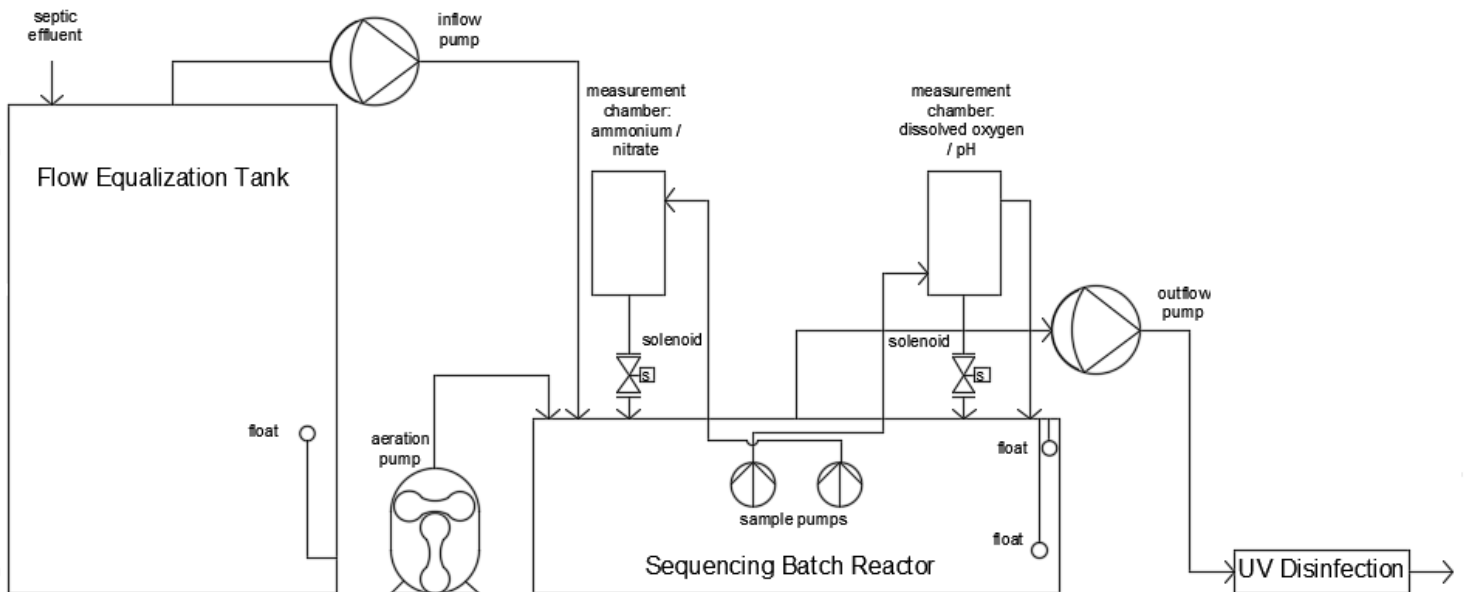

Figure 10. Hydraulic diagram of flow through the lab scale system.



Figure 11. Image of laboratory scale flow equalization tank, sequencing batch reactor, and disinfection.

## 9.2 Lab Scale System Sizing and Justification

The beginning of the lab scale system is the flow equalization tank. This piece of the lab scale system was modeled using a 55 gallon blue industrial plastic drum with a black removable lid. The lid has a 2.5 inch diameter threaded hole for a cap, which acts as the orifice from which the 3/8 inch decanter tubing emerges. A 1-5/8 inch hole was drilled 3 inches from the bottom of the tank in order to fasten a polypropylene bulkhead tank fitting with an EDPM gasket to the side. This fitting was used to thread the wires for the float sensor, as well as keep the hole watertight. The float sensor was attached using schedule 40 PVC piping configured to place the float sensor 11 inches from the bottom of the flow equalization tank. This ensures that the volume in the flow equalization tank is large enough to fill the sequencing batch reactor to approximately

13 gallons of treating water space. The bulkhead fitting opening is attached to a ½ inch Schedule 40 PVC Male Adaptor which is connected to a 90 degree elbow using a 1-1/2 inch piece of cut schedule 40 PVC, which is extended upward using a piece of 6 inch PVC connected to a schedule 40 end cap. The end cap has a 3/8 inch hole drilled out of it which was then threaded with the float sensor's male connector end.

A decanter was used to remove water from the flow equalization tank and deposit it into the sequencing batch reactor. This decanter was made with Styrofoam, shaped into a rectangle with dimensions of 14 x 11 x 2-1/2 inches. A hole was cut into the center and 3/8 inch tubing was glued in place using JB Water Weld. The 3/8 inch tubing connects to a 3/8 inch hose barb to ½ inch MPT adapter which screws into a Flojet pump, model 2100-12 Type IV. The pump is a self-priming diaphragm pump up to 7 feet vertical lift with a DC electric motor. It delivers from 1.0 to 2.0 GPM and operating pressures up to 50 PSI, works off 12 volts, and draws a current of 8 amps. Calculated when attached to the system the pump has a flow rate of approximately 1.3 GPM filling the tank in approximately 10 minutes. The pump was sized to deliver the treatable volume in a reasonable amount of time, as well as be sized at a velocity over 2 ft/s. The Ten State Standards note that a velocity of over 2 ft/s is required to prevent settling in the piping of a wastewater system (Wastewater Committee of the Great Lakes - Upper Mississippi River, 2014). The velocity is calculated to be approximately 8.5 ft/s, which is on the higher end of the allowable speed in the standards, but works well for the lab scale system filling speed.

The sequencing batch reactor is a tank with a lid, both made completely out of ¼ inch Plexiglas. The tank when glued together is approximately 36 x 12 x 12 inches. The lid is 37 x 13 x 2 inches. The tank is approximately 23 gallons, however the treatable volume is 13 gallons. The fill time for the tank is 10 minutes and the decanting time is approximately the same. Approximately 25% of the treatable volume is composed of moving bed biofilm reactors. This amount of MBBRs in the system increases the surface area by approximately 54 ft<sup>2</sup>. The maximum fill for MBBRs is approximately 70% of the treatable volume however the exact volume to add is dependent on the

application and convenience of the system (Odegaard, Rusten, & Westrum, 1994). In a large scale system the addition of more would be likely.

The lid has multiple holes for various purposes, including inflow to SBR, outflow from SBR, two for inflow to both sample chambers, two for sample chamber solenoids, pH and dissolved oxygen sample chamber outflow tubing, cords for sample pumps, aeration tubing, extra for gas and potential sodium bicarbonate, high float sensor, and low float sensor. Drilling into the lid made the system more likely to stay watertight, as well as easy to organize and more appealing visually.

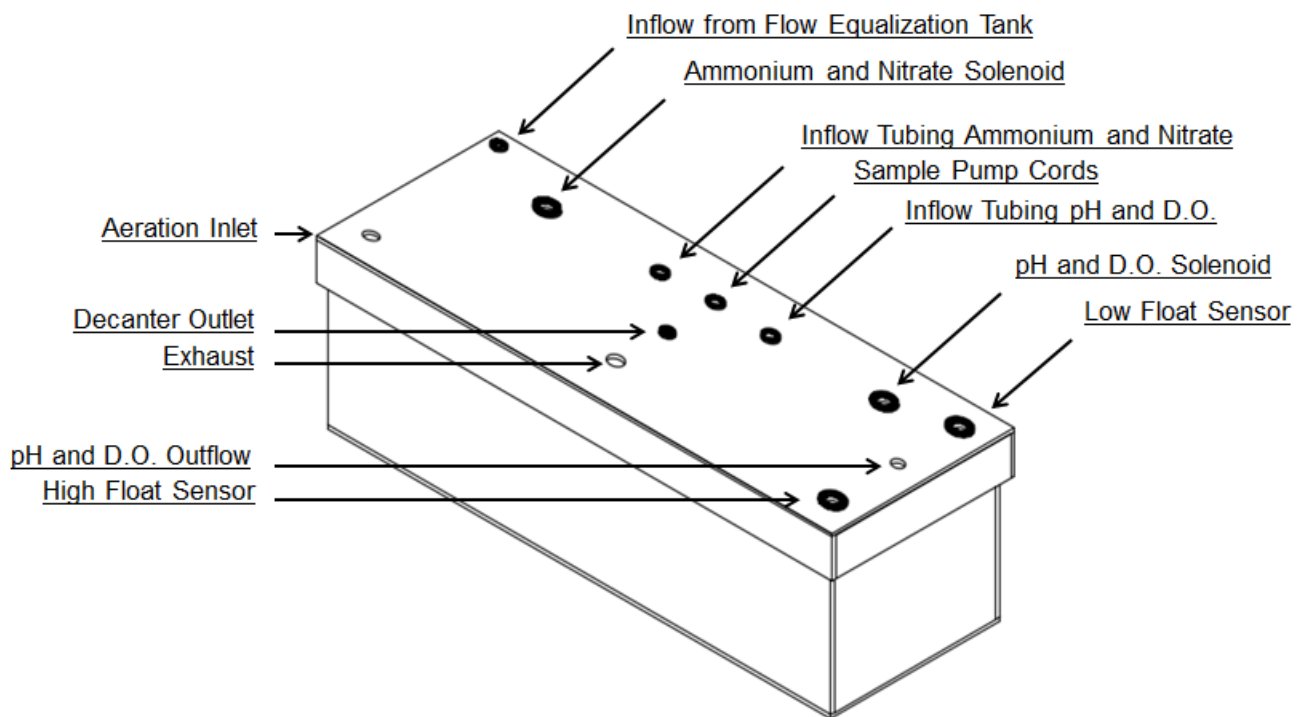

Figure 12. Sequencing Batch Reactor tank and lid with labeled entrance holes.

In the bottom of the tank is a Plexiglas removable tray, designed to hold up grating, hold down aeration, and be removed for lab scale design cleaning purposes. The base is composed of  $\frac{1}{4}$  inch Plexiglas while the sides are  $\frac{1}{2}$  inch Plexiglas. The height of the end pieces are  $2 \frac{1}{2}$ , just  $\frac{1}{4}$  inch taller than

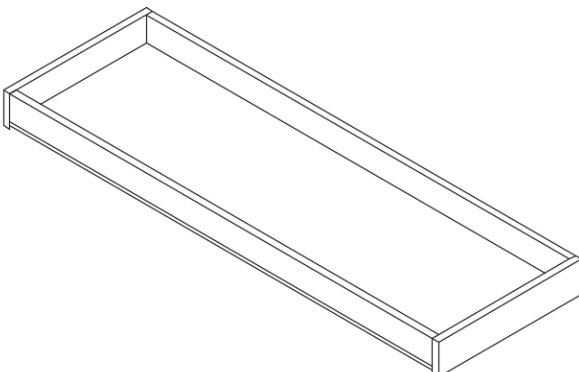

Figure 13. Sequencing Batch Reactor tray for aeration.

the rest of the system so that the aeration system was able to be tied down onto the tray with small cable ties through  $\frac{1}{4}$  inch holes drilled into the tray. The length of the tray is  $35 \frac{3}{4}$  inches and the width is  $11 \frac{3}{4}$  inches.

The aeration piping was crafted using  $\frac{1}{2}$  inch schedule 40 PVC. The aeration was sized to fit snugly in the bottom of the tank tray, while configured in a pattern that would evenly aerate the wastewater. The three horizontal lengths of piping were sized to be 32 inches



Figure 14. Aeration piping attached to the SBR tray.

long with 90 degree elbows connecting them to the two 4 inch pieces. The end is capped off and the entrance to the aeration is attached to a 90 degree elbow and 12 inch length of pipe which exits the lid and is attached to a  $\frac{1}{2}$  inch male adapter. The male adapter is then connected to a  $\frac{1}{2}$  inch threaded coupling which connects to a  $\frac{1}{2}$  inch male thread to  $\frac{3}{8}$  inch hose barb adapter. The aeration hosing connects to the aeration pump with another  $\frac{1}{2}$  inch male thread to  $\frac{3}{8}$  inch hose barb adapter. The holes drilled into the piping for aerating were spaced five inches apart, allowing for a significant number of holes. The holes drilled for the escapement of air are of size  $\frac{9}{64}$  inch.

The pump for aeration was sized up significantly from the original recommendations from the Ten State Standards. Originally the aeration pump was sized to be a small fish tank aerator, the Top Fin Aquarium Air-3000. The pump is recommended for a fish tank of size 40 US Gallons and has a flow rate of 0.78 GPM. The ten state standards recommend a minimum of 1.25 cfm/1000 gal (Wastewater Committee of the Great Lakes - Upper Mississippi River, 2014). This measurement would be approximately 0.01625 CFM or 0.12155 GPM for the 13 gallon treatment system. However, upon aerating the system it was clear that this minimum value would not enable a uniformly

mixed wastewater in the SBR in lieu of a mechanical mixing mechanism. Therefore, another aeration pump of nearly 75 times the CFM was chosen. The aeration pump used in the final system is the Rietchle Thomas model 927CA 18 diaphragm vacuum pump. The pump operates at a flow rate of 1.2 CFM, runs off of 115 Volts AC, and draws 3.6 Amps.

Above the aeration piping, resting on the SBR tray, are two layers of grating. The first layer is plastic knitting mesh with openings of 1/8 inch, also known as #5 mesh,

referring to the number of holes per linear inch. The second layer of grating is a layer of stainless steel grating cut to size. The second layer adds weight to aid in keeping the plastic mesh from floating up during aeration. Both mesh layers together help to disperse the aeration bubbles as well as keep the Moving Bed Biofilm Reactors and other significant solids from falling below and amongst the aeration system.

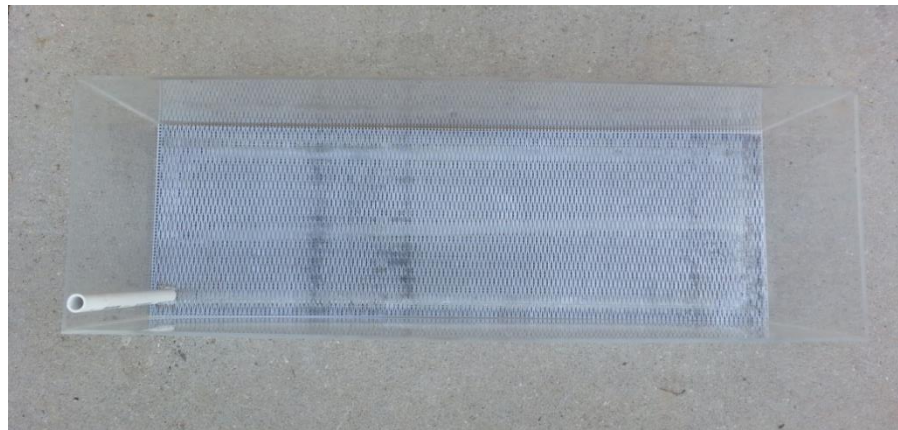

Figure 15. Layers of #5 mesh and stainless steel grate.

An important part of the sequencing batch reactor is the float sensors. The float sensors are attached through the lid of the sequencing batch reactor, using a similar method as in the flow equalization tank. The float sensors are attached to the end of a threaded 1/2 inch end cap as mentioned before, followed by a length of cut 1/2 inch schedule 40 PVC. The low sensor reaches down to hover just above the grating (9 inches below the lid) and is kept in place using a cable tie on the outside of the lid. The high sensor is attached in the same way but it located 2 inches below the lid, leaving a 7 inch height of treating water.

Apart from the sequencing batch reactor, two more liquid holding chamber designs were implemented. One is the sample chamber for the ammonium and nitrate probes, the second is the sample chamber for the dissolved oxygen and pH probes. The two chambers are nearly identical in design except for one minor difference. The dissolved oxygen sensor requires water to be moving past it, so the entrance to the chamber was placed low and the exit high, to allow for new water to fill up the chamber and spill out the top constantly. The ammonium and nitrate sensors prefer water to be stagnant, therefore there is no higher opening for an exit, there is a high exit for an entrance in order to let the water fill it up and sit without moving for readings.



Figure 16. Ammonium and Nitrate Sample Chamber.

The sample chambers are built out of all 4 inch schedule 40 PVC and have an approximate volume of 0.7 gallons that fill in approximately 40 seconds. The top is composed of a DWM PVC Cleanout adapter SP x FPT and a DWV PVC cleanout plug.



Figure 17. Dissolved Oxygen and pH Chamber.

The plug has two 1 inch diameter holes drilled into them which contain the top 1-1/2 inch portion of two storage solution sensor bottles. The sensor bottles are glued into the plus using JB Weld. Using this method allowed for the sensors to be easily removed and cleaned, as well as kept the sensors in place with tightening grommets. The middle of the chamber is composed of a coupling which attaches to a 4-1/2 cut piece of 4 inch schedule 40 piping, which connects to a DMV cap, which composes the bottom.

Each chamber has a 5/8 inch hole drilled into the bottom to allow for the connection of a solenoid. On both chambers an ASCO 1/2 inch solenoid was attached using a threaded connecting piece of PVC. The solenoid on the ammonium and nitrate chamber dropped water

out every time a sample was taken, however because water needs to be moving through the dissolved oxygen and pH chamber, the solenoid will only be employed if there are no samples being taken and the sequencing batch reactor is not being used.

The ammonium and nitrate chamber has an entrance 2 inches from the top, with a 3/4 inch threaded to 1/4 inch hose barb which allows for 3/8 inch outer diameter tubing to carry water from the sample pump into the chamber. The dissolved oxygen and pH chamber has an entrance 1-1/2 inches from the bottom which allows for water to be carried in through a 3/4 inch threaded to 1/4 inch hose barb through outer diameter inch tubing. This chamber has an exit in order to allow for the water to continuously flow

through. The exit hole is 2 inches from the top of the chamber and has a  $\frac{3}{4}$  inch threaded to  $\frac{3}{4}$  inch hose barb, which allows for water to flow out through 1 inch outer diameter tubing.

In order to pump the water from the sequencing batch reactor into sample chambers, pumps were chosen to allow for water to pump in and be able to take a reading every six minutes. The original pumps chosen were two aquarium pumps made by Sicce called the Mi Mouse. These pumps are submersible recirculation pumps that are equipped with a variable flow rate regulator and operate at 82 GPH. The max head is 1.8 ft, the voltage is 120 volts, and draws current of 0.084 amps. These first generation pumps did not have a way of easily attaching them to the wall of the SBR,



Figure 18. First generation sample chamber pumps.

so a device was constructed using Plexiglas and flexible metal in order to hang the pumps down into the tank. The true downfall of using these pumps was the position of the inlet. The pumps were above part of the aeration system, so when the aeration would turn on air bubbles would enter into the inlet and the pumps would not be capable of sending water up from the SBR into the sample chambers. Therefore, another generation of pumps was needed.



The second generation of pumps used was the Top Fin Power Head 30. The choice of this pump was preferable for multiple reasons. First, the position of the inlet faces to the side and includes a water inlet strainer. The position and strainer both greatly decrease the likelihood that air bubbles will enter the

Figure 19. Second generation sample chamber pumps.

pump while aeration is running. Second, the pumps are equipped with four small suction cups, therefore mounting was simplified. The second generation pumps have a flow rate of 118.89 GPH and a voltage of 120 V. It is also a position outcome that the sample chambers fill up faster than they did with the first generation pumps.

Settling in a sequencing batch reactor is inevitable; therefore a method for removing water that will disturb settled solids the least is preferable. A decanting mechanism was built for this purpose.

The first generation of decanting was built using Styrofoam. This recycled material was adequate at floating, however it flaked off bits of



Figure 20. First generation sequencing batch reactor decanter.

Styrofoam into the system which would make the water inadequate to discharge. The structure also had issues interfering with, float sensors and inlet tubing. The first generation decanter was designed in an elongated H shape in order to prevent it from hitting the sample chambers, however as the design of the sequencing batch reactor evolved, so did the decanter. In addition to the Styrofoam, a 90 degree hose barb was fixed to a 2 inch piece of 3/8 inch tubing, which was glued into a 3/8 inch hole in the decanter to serve as an outlet and attachment for the 3/8 inch tubing leading out of the sequencing batch reactor.

The second generation decanter was built using 1/2 inch schedule 40 PVC. The need for a second generation arose from the very specific final location of pumps, float sensors, and tubing in the sequencing batch reactor. The decanter needs to be able to move freely vertically, but have more restricted movement horizontally. The entire decanter is composed of a 1-1/2 inch length of tubing, a 90 degree 3/8 inch hose barb, a 10 inch

of flexible silicone tubing, two cross fittings, four tee fittings, two 90 degree elbows, six end caps, and various lengths of standard ½ inch schedule 40 PVC.



Figure 21. Second generation sequencing batch reactor decanter.

Being completely waterproof, the PVC decanter floats evenly atop the water's surface. The inlet was drilled using a 3/8 inch drill bit and fits the small piece of ridged tubing with the hose barb snugly as well as has a layer of JB Water Weld to ensure that it is water proof. At the longest points on the decanter the final dimensions are approximately 35-3/4 inches and 11-3/4 inches.

The pump attached to the decanter is identical to the one used for inflow into the Sequencing Batch Reactor. The flow rate for the disinfection system used is approximately 3.0 GPM, therefore the 1.3 GPM Flo Jet pump allows for enough time for disinfection to occur properly.

The ultra violet light disinfection chosen for use in the lab scale system is the Sterilight Silver SSM-17. Rated at a flow rate of 3.0 GPM, voltage of 100 to 240 V, and a 0.6 Amp maximum. After disinfection the lab scale water was tested for consistency in the laboratory.



Figure 22. Sterilight Silver SSM-17 UV Disinfection.

## 10.0 Integrated Control Design

### 10.1 Hardware

The control panel located directly above the SBR is equipped with the following electronic components:

- power strip
- 120 volt AC to 12 volt DC transformer
- two breadboards
- Arduino Uno microprocessor
- three solid-state relays
- eight electromechanical relays
- three 10k ohm resistors
- three float sensors
- four analog protoboard adapters
- two ion-selective electrodes
- pH probe
- dissolved oxygen probe

The three solid-state relays deliver power accordingly to the components that require 120 volts AC to operate, including the two sample pumps and the aeration pump. Their coil voltage is only five volts, making them ideal for application with an Arduino Uno, which is only capable of generating an output of five volts. The two solenoids, inflow pump, and outflow pump, only require 12 volts DC to operate and are relayed power from the transformer via the electromechanical relays, which can be applied to circuits experiencing direct current. Furthermore, the resistors are each utilized as pull-down resistors in conjunction with the float sensors, reducing the leakage of any stray voltage. Most importantly, the analog protoboard adapters allows the sensors to interface with the Arduino Uno through transmission of an analog signal.

## 10.2 Sensors

As mentioned in the previous list, the sensors used in this lab-scale system include an ammonium selective electrode, nitrate selective electrode, pH probe, and dissolved oxygen probe. The justification for implementing these sensors is directly related to the reactions involved with the process of nitrogen removal. It is worth noting that the NPDES permit being used to model this system has a discharge limitation written in terms of ammonia concentration, opposed to ammonium; however, in terms of design, application of an ammonium sensor is far more feasible and simplistic. Typically, wastewater exists between a pH of 6 and 8. As seen in figure 23 below, for that pH range, over 90% of the species in solution is expected to be ammonium.

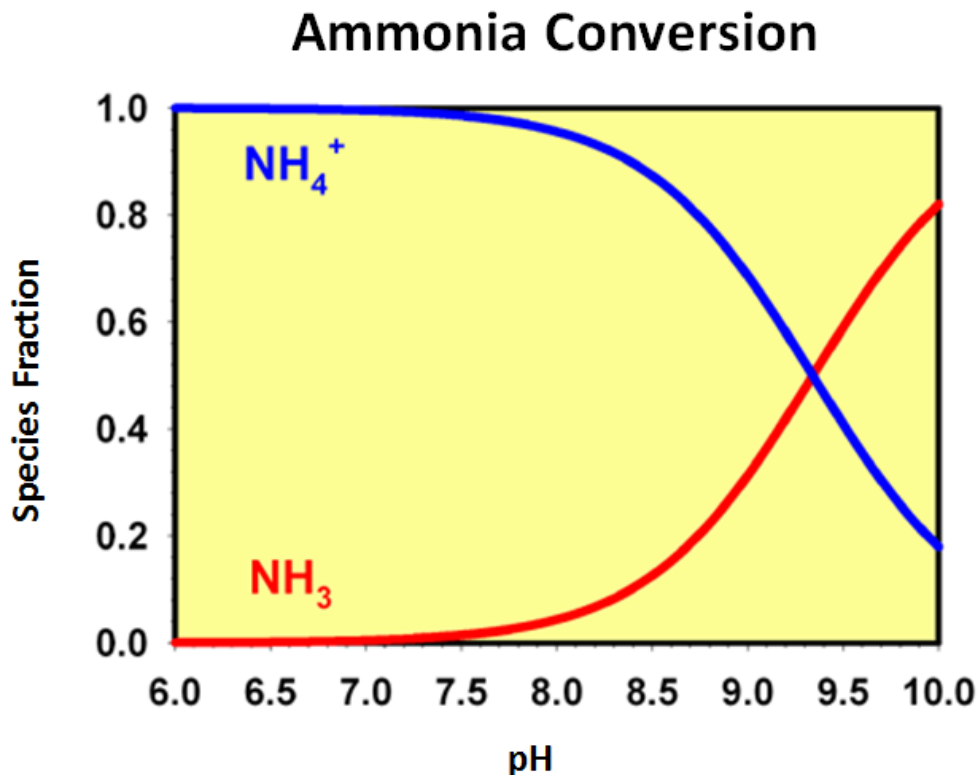

Figure 23. Revealing the relationship between ammonium and pH.

Therefore, to use an ammonia sensor, it would be necessary to increase the pH of the sample through addition of a reagent to achieve an accurate measurement. This additional step would complicate the sampling process, and the reagent could skew the results of other sensors. With implementation of the ammonium, nitrate, pH, and dissolved oxygen sensors, it is possible to follow and quantify the process of nitrogen

removal. As for operation and calibration, both ion-selective electrodes are governed by the Nernst equation -- an equation that models electromotive forces.

$$E = E_0 + m(\ln C) \quad (5)$$

where

E = measured voltage

E<sub>0</sub> = standard potential for combination of two half cells

m = slope

C = concentration of measured ion species

By creating stock solutions of varying concentrations and plotting them against voltage readings measured from the electrode, an exponential relationship becomes clear. Taking the natural logarithm of the concentrations and once again plotting that information against the voltage outputs, develops a linear relationship. (The ammonium calibration process is identical to the nitrate calibration process, but the nitrate calibration plots can be found in the appendix.)

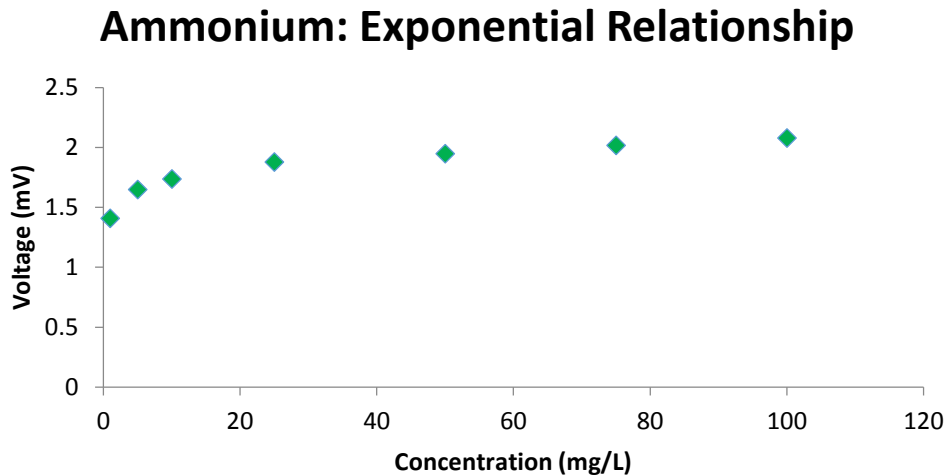

Figure 24. Graph of ammonium exponential relationship.

## Ammonium Calibration

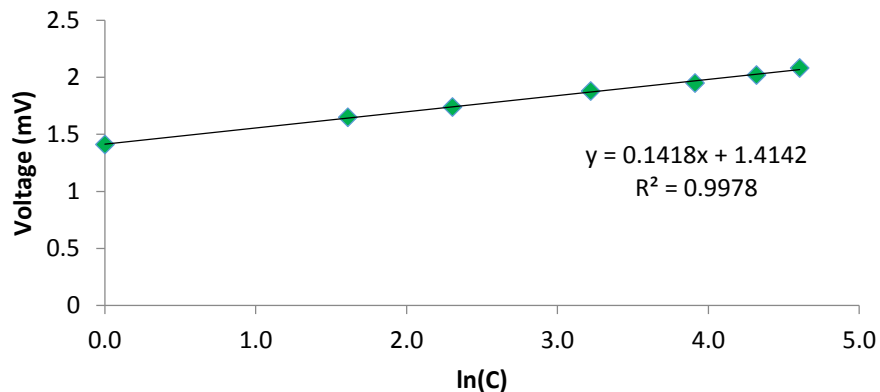

Figure 25. Graph of ammonium calibration.

The slope and intercept are then applied to the software so that the voltages can be immediately converted to concentrations during data acquisition. The equation below was derived by isolation of concentration in the Nernst equation; therefore, all variables are the same as previously defined.

$$C = e^{\left(\frac{E-E_0}{m}\right)} \quad (6)$$

The pH and dissolved oxygen sensors both have a direct linear relationship with measured voltage, as seen in fig below.

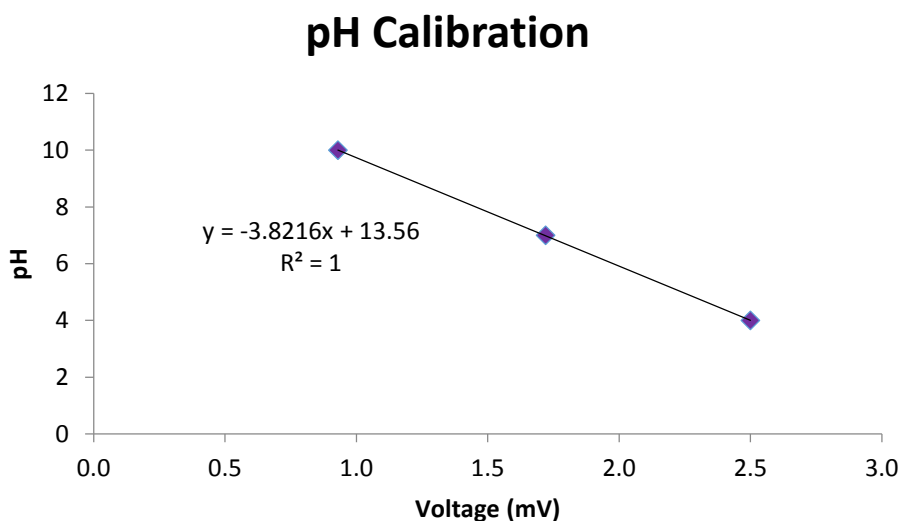

Figure 26. Graph of pH calibration

Upon calibration, the slope and intercept is applied to a linear equation that interprets voltage into either pH or dissolved oxygen concentration. (The dissolved oxygen calibration process is identical to the pH calibration process, but the dissolved oxygen calibration plots can be found in the appendix.)

$$y = m(E) + b \tag{7}$$

where

y = pH or DO concentration

m = slope

E = measured voltage

b = intercept

The operational constraints of the sensors were a limiting factor that required particular attention with regards to design. Upon programming, calibrating, and submerging all 4 sensors in the same sample, it was discovered that major electronic interference exists amongst the sensors, leading to erroneous measured concentrations and values; however, if powered individually and allowed time to cycle through each sensor, a complete data set containing all 4 values can be generated in a timely manner. By pairing each sensor with a relay, power could be delivered to each sensor for an allotted amount of time, completely expelling any electrical interference.

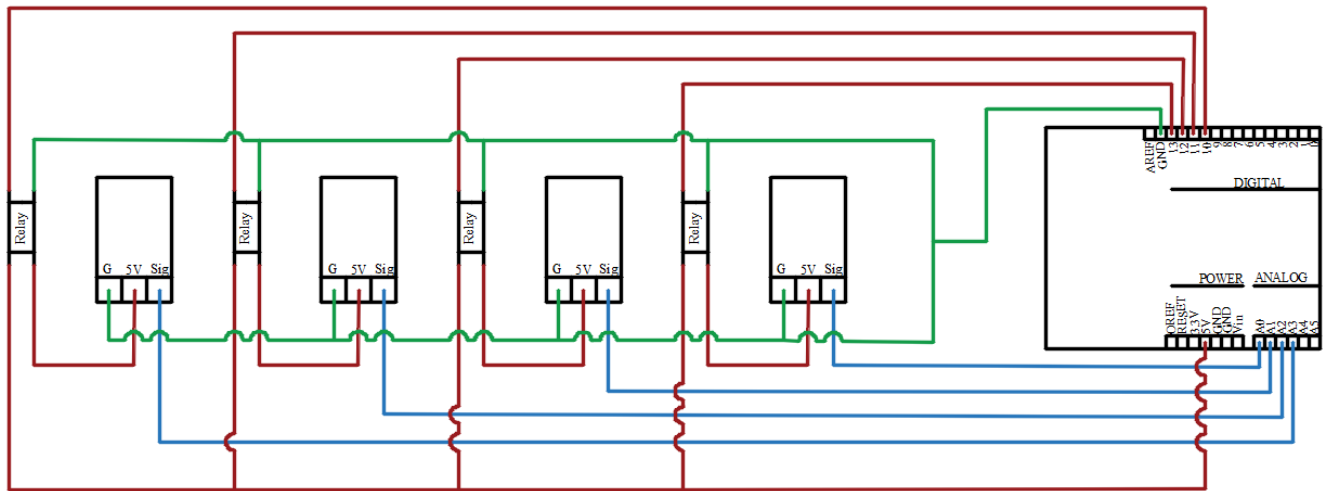

Figure 27. Circuit Diagram

Yet, allotting enough time for each sensor to stabilize is also crucial when acquiring accurate data. The initial software was written so that each sensor had 20 seconds to stabilize and report a measurement. With a total of 4 sensors, this seemed ideal, considering it would be possible to cycle through all the sensors and compose a complete data set in only a minute. After running this original software, it was quite clear the concentrations reported were incorrect. Upon this realization, the time required for each sensor to stabilize was thoroughly researched. To measure the capability and sensitivity of the sensors, each was exposed to a known concentration or pH change and the time required to reach a stabilized measurement was recorded.

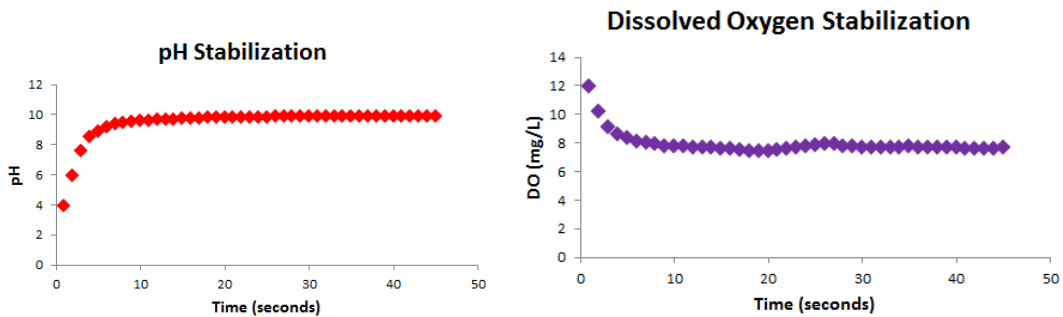

Figure 28. pH and dissolved oxygen stabilization time curves.

As seen in the pH stabilization plot, upon removing the sensor from a pH 4 stock solution and placing it in a solution of pH 10, the sensor was capable of completely stabilizing in a matter of 10 seconds. The DO probe's ability to stabilize was tested within its prospective sample chamber. For this test, tap water was merely pumped in via the sample pump and the time required for the DO reading to stabilize was recorded. Similar to pH sensor, the DO sensor experienced stabilization in approximately 10 seconds. Even though the pH and DO probes are capable of measuring and reporting accurate values in a rapid manner, the ion-selective electrodes require more time to stabilize and are definitely a limiting factor with regards to the time needed for data acquisition.

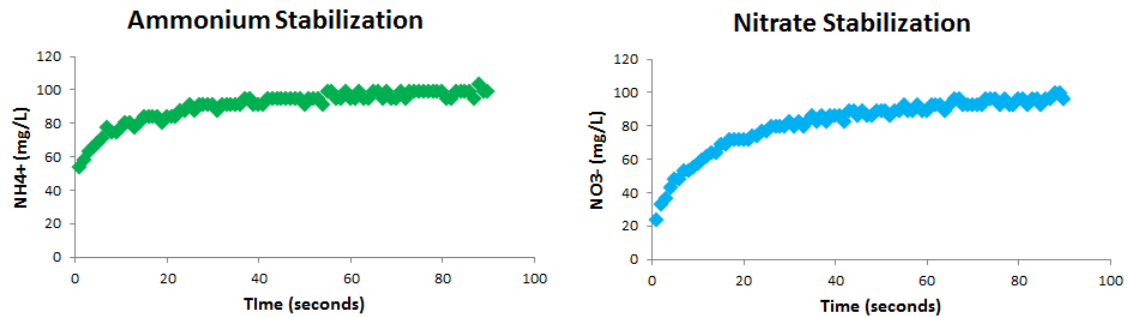

Figure 29. ammonium and nitrate stabilization time curves.

In both of the plotted scenarios above, the sensors were removed from a stock solution of 1 mg/L, then immediately submerged in a stock solution of 100 mg/L. The ammonium ISE experienced stabilization around the minute mark, but the nitrate sensor did not start experiencing stabilization until approximately 75 seconds. Equipped with this knowledge concerning the limitations of the sensors, it was possible to update and alter the Arduino software to produce more accurate values. As a precaution, in the second generation of the software, it was programmed to power each sensor individually for a period of 2 minutes, ensuring accurately measured values. However, the increased time interval was not ideal for the procurement of real-time data, explaining yet another reason for the necessity of the multiple sample chambers. By having two sample chambers, it is possible to have two sensors powered simultaneously, each in its own isolated chamber. If the sensors were all in one chamber and had to be powered individually, between the 2 minutes required for each sensor and time to pump in and out, it would take nearly 10 minutes to obtain a full data set composed of pH, ammonium, DO, and nitrate values. As a result of the two sample chamber design, the time required to obtain a data set it only 6 minutes.

## 10.2 Software

The system's software has been programmed through Arduino and Python. The bulk of the logic exists in Arduino, while the code composed in Python provides a means of plotting live data and transferring the values to excel. As the Arduino code conducts and collects the various measurements, the Python code interprets and plots the data so

that an operator can visually comprehend the state of the system. Essentially, the logic composed in the Arduino interface mirrors the nitrogen cycle. By constantly measuring the change in certain nitrogenous compounds, it is possible to identify different stages in the process of nitrogen removal.

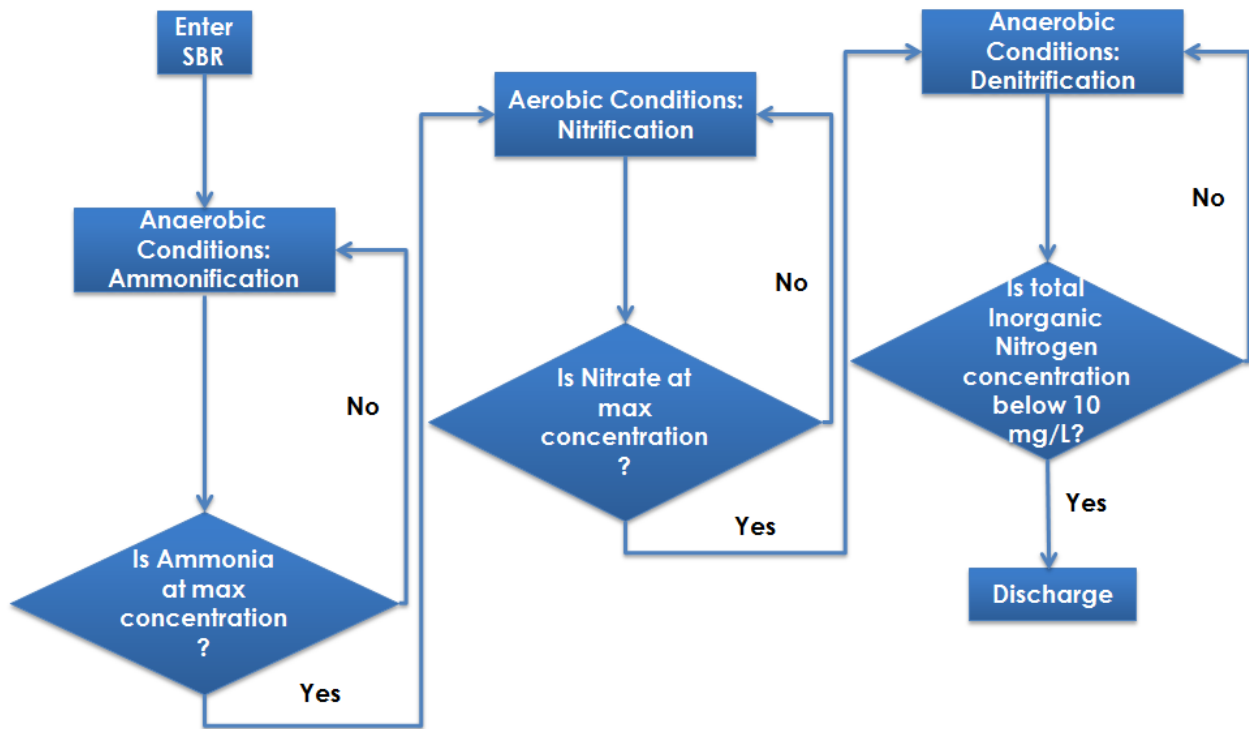

Figure 30. Sensor logic diagram.

As seen in the flowchart above, the program was composed to change the environmental conditions based on the prevalence of ammonium or nitrate. Every 6 minutes, a full data set containing all 4 values (pH, ammonium, DO, and nitrate) is generated; however, the manner in which the software interprets those data points is contingent on the state of nitrogen removal. When water first enters the SBR, the water will be monitored for ammonification. After taking the first ammonium measurement, the value is saved in E<sup>2</sup>PROM. During the second round of measurements, the new ammonium measurement is subtracted from the old ammonium measurement, and then the new measured concentration replaces the previous in E<sup>2</sup>PROM. This process continues until the absolute value of the new measurement minus the old measurement

becomes less than 1. If the absolute value is greater than 1, clearly the system is still experiencing conversion of organic nitrogen to ammonium, yet if the absolute value is less than 1, the ammonium concentration is stabilizing, and ready for conversion to nitrate. To act as a fail-safe mechanism, if this requirement is satisfied, and the system is required to take another ammonium measurement and once again produce an absolute value below 1. Once in the nitrification state, the same logic is repeated, except with nitrate measurements. Upon exiting the nitrification state, nitrate measurements are still saved to E<sup>2</sup>PROM and compared to the new measurements during the denitrification state. This time, the comparative process is used to determine when the concentration of nitrate has reached a minimum, meaning the available nitrate has converted into nitrogen gas.

## **11.0 Results**

Values for ammonia, pH, and dissolved oxygen were found using laboratory calibrated sensors. Values for total coliform count and E.coli were found through the use of standard laboratory testing. This testing included making 1 ml, 2ml, 3ml, 4ml, and 5ml dilutions of wastewater sample with the remainder of the sample being deionized water. The sample is mixed with Coli-ert and incubated in quanti-trays for 24 hours. The total coliform count is found by counting the number of yellow wells and the E.coli count is found by counting the number of wells that are both yellow and fluorescing. These values are compared to a chart and multiplied with their respective dilution values.

Table 2. Comparison of residential and school wastewater values.

Name	Unit	Residential Septic Effluent	School Septic Effluent
Ammonia	mg/L	61	158
Total Coliform	#/100mL	148,000	150,000
E.coli	#/100mL	61,600	75,000

Obtaining enough school effluent to treat in the lab scale SBR proved to be an issue due to the school's distance from the lab. In hopes of achieving a more continuous system and seamless process, the septic effluent pumped into the SBR was sampled from a residential location on property owned by the University of Tennessee. It is crucial to note the source of the septic effluent because of the drastically different ammonia concentrations among sources, seen in Table 2. For the means of prototyping the system and the sake of availability, residential wastewater was utilized to gauge the system's effectiveness at removing nitrogen and other contaminants.

### Trial 1: DO vs. Time

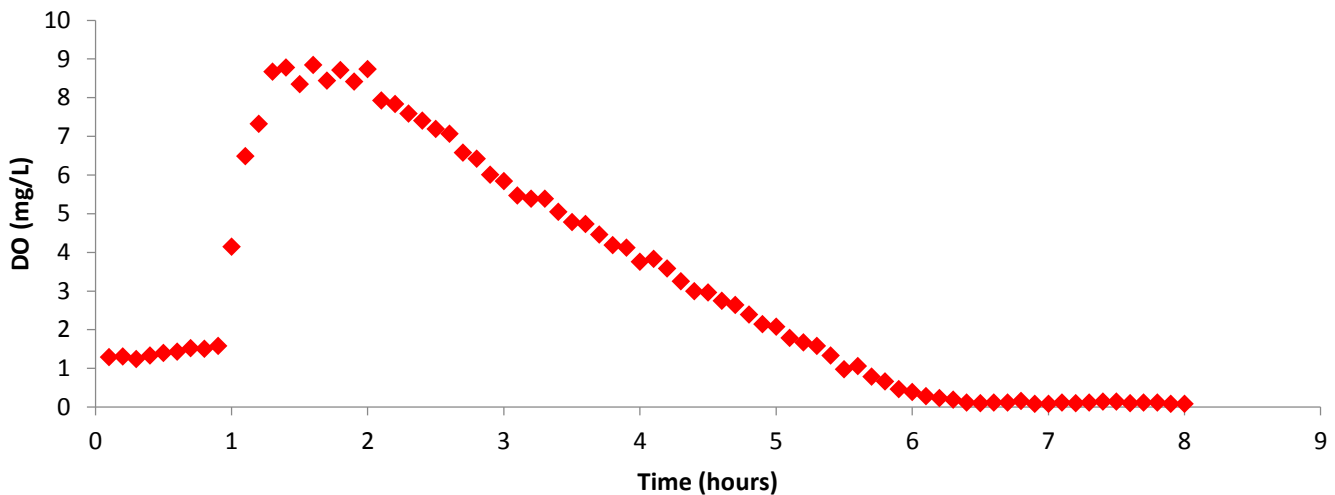

Figure 31. Results for dissolved oxygen during trial 1.

## Trial 1: Ammonium vs. Time

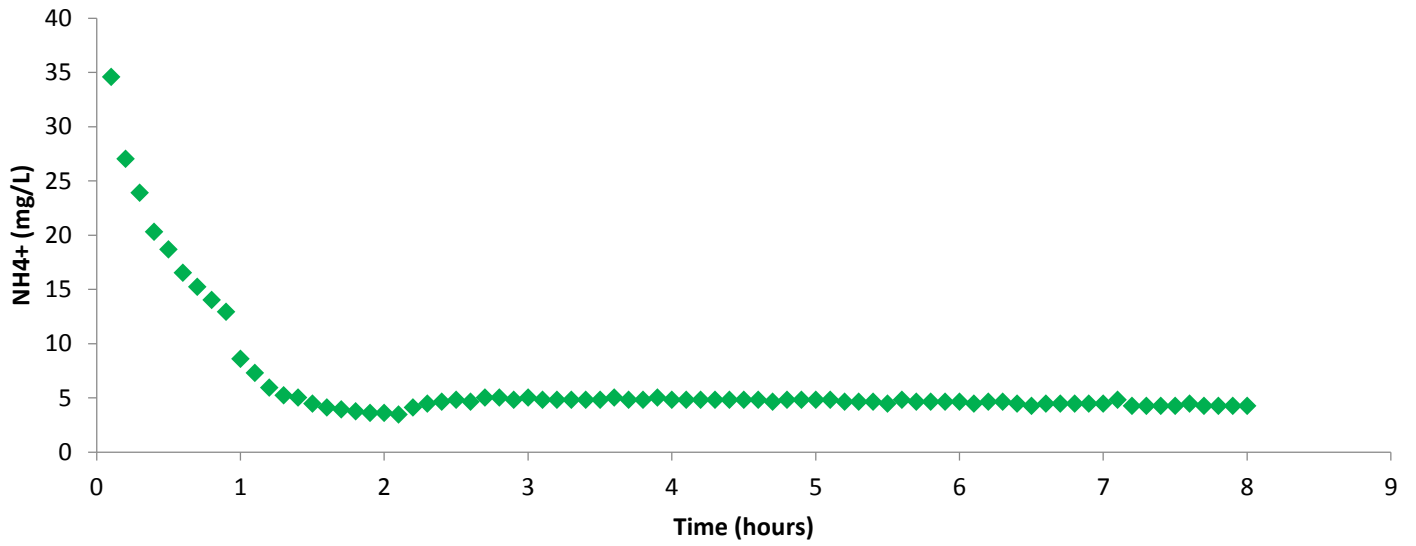

Figure 32. Results for ammonium during trial 1.

## Trial 2: DO vs. Time

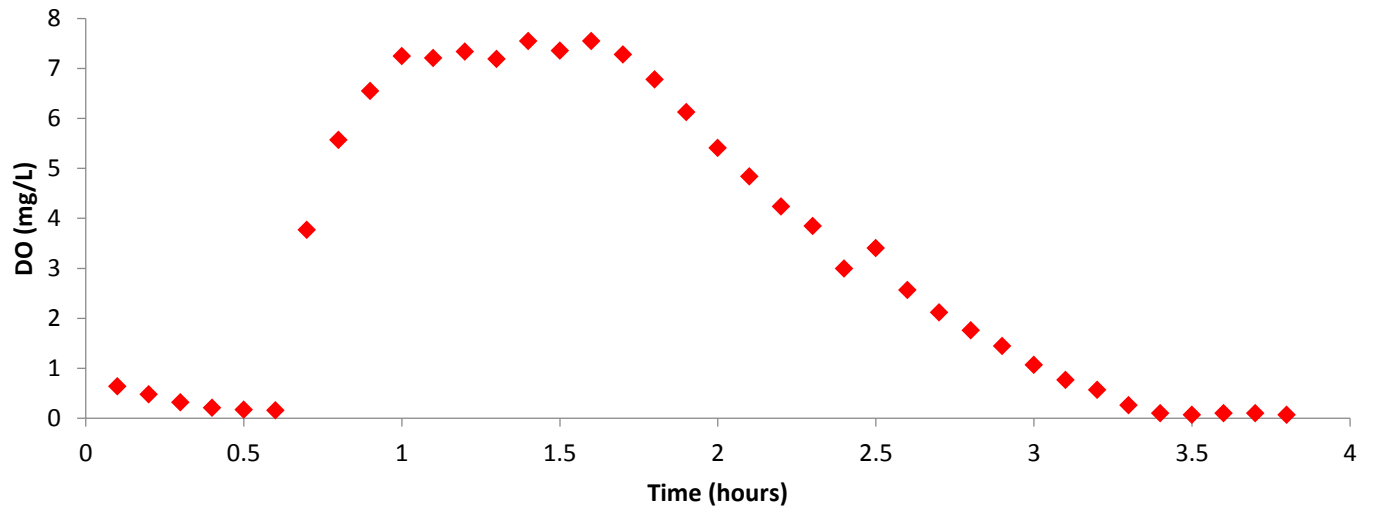

Figure 33. Results for dissolved oxygen during trial 2.

## Trial 2: Ammonium vs. Time

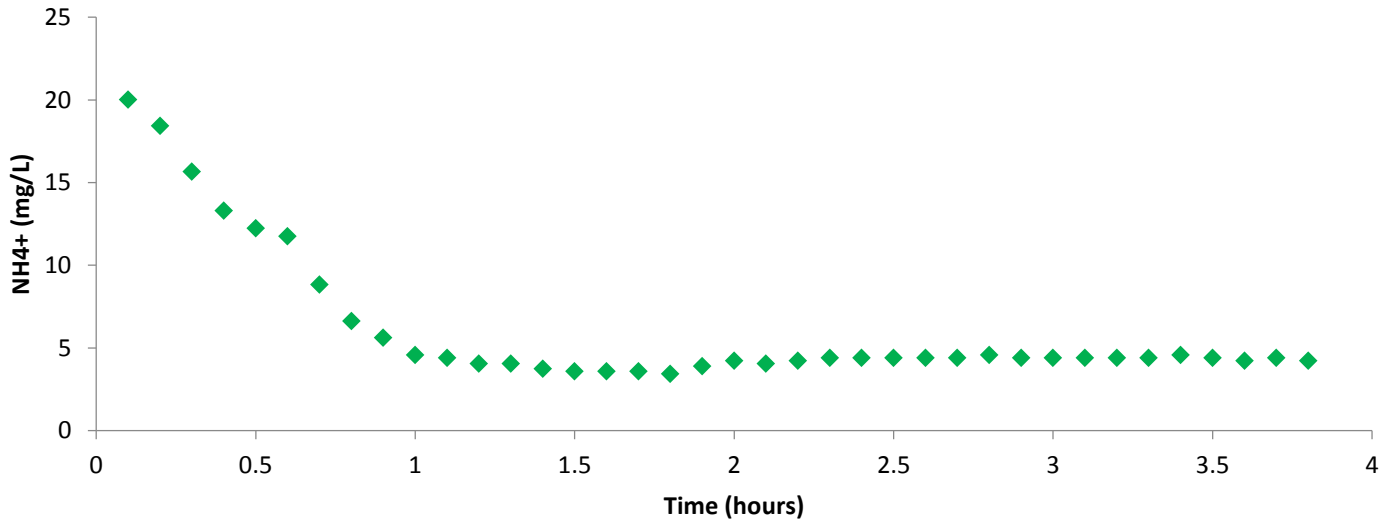

Figure 34. Results for ammonium during trial 2.

Figures 31 through 34 are plots of the concentrations measured by the dissolved oxygen and ammonium probes collected via the software described in the previous section. Figures 31 and 32 represent the first trial, and Figures 33 and 34 represent the second trial. Both trials followed the expected ammonification and nitrification trends. Upon enter the SBR, ammonium concentrations were at their maximum, allowing for nitrification to commence soon after entering the tank. As seen in both trials, small amounts of ammonium conversion were occurring prior to aeration; this conversion can be explained by the small concentration of dissolved oxygen already present in the water. Once aeration occurred, nearly all ammonium experienced conversion, eventually stabilizing at a concentration of approximately 5 mg/L. As expected, the septic effluent was anoxic when initially entering the system and experienced a dramatic spike in dissolved oxygen during aeration to approximately 8.5 mg/L. To become fully aerobic, the system only required approximately 30 minutes, but to reenter an anoxic state, the SBR required an extensive amount of time. During the first trial, the SBR took four hours to become anoxic; however, during the second trial, the SBR only required approximately two hours. This drop between trials in the time necessary to become anoxic is indicative of the growing populations of bacteria in the system. Since the SBR probably had larger populations of bacteria for the second trial, the oxygen demand was

greater, decreasing the time to become anoxic. Unfortunately, due to biological constraints, successful denitrification was not witnessed. Without an adequate population of denitrifiers, conversion of nitrate to nitrogen gas cannot be expected to take place. The denitrifiers are delicate bacteria that have slower reproductive cycles compared to the other microorganisms in the system.

Table 3. Values for NPDES requirements, septic effluent, and system effluent from trials 1 and 2

Name	Units	NPDES Values (Daily Maximum)	Septic Effluent	Trial #1	Trial #2
Ammonia	mg/L	10	61	42	46
pH	—	6 - 9	7.37	7.69	7.74
Dissolved Oxygen	mg/L	6	0.63	0.29	0.47
Total Coliform	#/100mL	—	148,000	100	185
E.coli	#/100mL	941	61,600	< 1	< 1

The first trial was conducted without MBBRs, whereas the second trial was conducted in the presence of MBBRs. Although the values between trials do not differ significantly, it is suspected that the longer the MBBRs are in the tank, the more they will contribute to nitrogen removal. As seen in Table 3, averaged between trials 1 and 2, the system removed 27.9% of the ammonia and nearly 100% of the E. coli.

## 12.0 Conclusion

The process of ammonification and nitrification followed the expected theoretical trends. Unfortunately, due to biological constraints, there was not an excessive amount of denitrification. Without an adequate population of denitrifiers, conversion of nitrate to nitrogen cannot be expected to take place. As the system continues to treat batches, the necessary colonies of microorganisms will continue to grow. Already it is noticeable based on the second trial that the time to induce anoxic conditions is decreased, meaning there is a growing population of microorganisms cultivating within the SBR.

### 12.1 Budget

An element of success for this project was depended on whether or not the lab scale system could be built at a reasonable price and within the constraints of the allotted money for the project. Having a budget restraint had an effect on the choice of sensors especially. Typically the Vernier sensors chosen are used for less industrial settings and not necessarily used to detect various concentrations in wastewater. In a true sensing unit the sensors would be of a higher price, yet more durable and resilient.

The amount of money allotted for the project was \$3,000, however not all of it was used. For supplies implementing into the lab scale system, approximately \$1,730 was spent. As mentioned before, if being implemented long term in a large scale treatment system the price for sensors would increase from \$700 and the price for the sample chambers would stay approximately the same, however, the price for the lab scale sequencing batch reactor would not need to be included.

<u>Supplier</u>	<u>Item</u>	<u>Cost</u>
Vernier	Sensors	\$699.00
Hach	Calibration Chemicals	\$132.48
Delcity	Solenoid Valves	\$264.82
Home Depot	Lumber for System Stand	\$80.47
Arduino	Arduino Uno Board	\$24.95
Ace Hardware	PVC joints, piping, and tubing	\$75.86
Aquariums of Knoxville	Sample Chamber Pumps	\$20.79
Fisher Science	Sensor storage solution	\$96.10
Laser Precise	Reactor Acrylic and cutting	\$150.48
Radioshack	Electronic Components	\$104.92
Home Depot	Sample Chamber Supplies	\$65.46
Digi Key Corp.	Electronic Components	\$13.62
	<b>Total</b>	<b>\$1,728.95</b>

## 13.0 Recommendations

- Continue testing to obtain multiple trials of data
  - Test using wastewater collected from the school
- Apply wireless capabilities and develop a downloadable app for notification
- Implement use of industrial-grade sensors
- Test sample chambers in a large scale system
- Develop a more rigorous statistical analysis to determine the presence of outliers
- Implement fail safe mechanisms, including multiple float switches

## References

A V Systems, Inc. (2008). *NPDES Sample Documents*. Retrieved from Material Inventory Report System:  
<http://www.mirsinfo.com>

Burian , S., Nix, S., & Durrans, S. (2000). Urban Wastewater Management in the United States: Past, Present, and Future. *Journal of Urban Technology*, 33-62.

Chapman, S., Leslie, G., & Law, I. (2000). *Membrane Bioreactors (MBR) for Municipal Wastewater Treatment - An Australian Perspective*. Australia: CH2M HILL.

Detroit Water and Sewerage Department. (2003). *Diurnal Flow Analysis of Wastewater Treatment Plant Influent*. Detroit: Detroit Water and Sewerage Department.

Fondriest Staff. (2010, August 2). *The Nitrogen Cycle*. Retrieved from Environmental Monitor:  
<http://www.fondriest.com>

Gurpal, S., Lusk, M., & Obreza, T. (2011, November). *Onsite Sewage Treatment and Disposal Systems: Trace Organic Chemicals*. Retrieved from IFAS Extension: University of Florida:  
<http://edis.ifas.ufl.edu>

HeadworksBIO. (2015). *Active Cell: MBBR/IFAS Wastewater Treatment*. Retrieved from HeadworksBio:  
<http://www.headworksinternational.com>

Lenntech. (2003). *Part II of Matter Cycles: The Nitrogen Cycle*. Rotterdam, The Netherlands: Lenntech.

Macalester College. (n.d.). *History of Wastewater Treatment in the United States*. Retrieved from Urban Wastewater Management in the Great Lakes Watershed: <http://www.macalester.edu>

National Small Flows Clearinghouse. (2004). The Attached Growth Process - An old technology takes on new forms. *Pipeline* , 1-7.

Odegaard, H., Rusten, B., & Westrum, T. (1994). A New Moving Bed Biofilm Reactor - Applications and Results. *Wat. Sci. Tech.*, 157-165.

SOPAC. (1999). *Report on Project Criteria, Guidelines, and Technologies*. Suva, Fiji: South Pacific Applied Geoscience Commission.

Sun Plumbing. (2015). *How do Septic Systems Work*. Retrieved from Sun Plumbing:  
<http://www.sunplumbing.com>

The United States Environmental Protection Agency. (1999a). *Wastewater Technology Fact Sheet: Chlorine Disinfection*. Washington, D.C.: EPA.

The United States Environmental Protection Agency. (1999b). *Wastewater Technology Fact Sheet: Ozone Disinfection*. Washington, D.C.: EPA.

- The United States Environmental Protection Agency. (1999c). *Wastewater Technology Factsheet: Ultraviolet Disinfection*. Washington, D.C: EPA.
- The United States Environmental Protection Agency. (1999d). *Wastewater Technology Factsheet: Sequencing Batch Reactor*. Washington, D.C.: EPA.
- The United States Environmental Protection Agency. (2000). *Wastewater Technology Factsheet: Trickling Filters*. Washington, D.C.: EPA.
- The United States Environmental Protection Agency. (2007). *Wastewater Management Factsheet: Membrane Bioreactors*. Washington, D.C.: EPA.
- The United States Environmental Protection Agency. (2012). *Learn about Small Wastewater Systems*. 2012: EPA.
- The United States Environmental Protection Agency. (2014). *Water: Permitting (NPDES)*. Wasington, D.C.: EPA.
- The United States Environmental Protection Agency. (2015). *Summary of the Clean Water Act*. Washington, D.C.: EPA.
- University of Michigan Center for Sustainable Systems . (2015, November 20). *Factsheets Water*. Retrieved from U.S. Wastewater Treatment: <http://css.snre.umich.edu>
- VANIS Industrial Automation. (2015). *Wastewater Solutions*. Retrieved from VANIS Industrial Automation: <http://www.vanis.hr>
- Washington State Department of Health. (2003). *Septic Tank Effluent Values*. Seattle: Washington State Department of Health.
- Water Environment Research Foundation. (n.d.). *Fact Sheet T2 Treatment Series: Suspended Growth Aerobic Treatment*. Alexandria, VA: WERF.
- Weaver, G. (n.d.). *Nitrogen Removal from Wastewater: A Primer*. New London, CT: The Water Plant Company. Retrieved from The .
- Westerling, K. (2014). *Biological Treatment 101: Suspended Growth vs. Attached Growth*. Retrieved from Water Online: <http://www.wateronline.com>
- Wiesmann, U., Choi, I., & Dombrowski, E. (2007). *Fundamentals of Biological Wastewater: Historical Development of Wastewater Collection and Treatment*.
- Winzler & Kelly Consulting Engineers. (2003). *City of Antioch Wastewater Collection System Master Plan*. San Francisco, CA: City of Antioch.
- World Bank Group. (n.d.). *Introduction to Wastewater Treatment Processes*. <http://www.worldbankgroup.org>: WBG.

# Appendix

## A.1 Drawings

### List of Drawings:

- Sequencing Batch Reactor Tank
- Sequencing Batch Reactor Lid
- Sequencing Batch Reactor Cutting Diagram
- Sequencing Batch Reactor Isometric
- Dissolved Oxygen and pH Sensor Sample Chamber
- Ammonium and Nitrate Sensor Sample Chamber

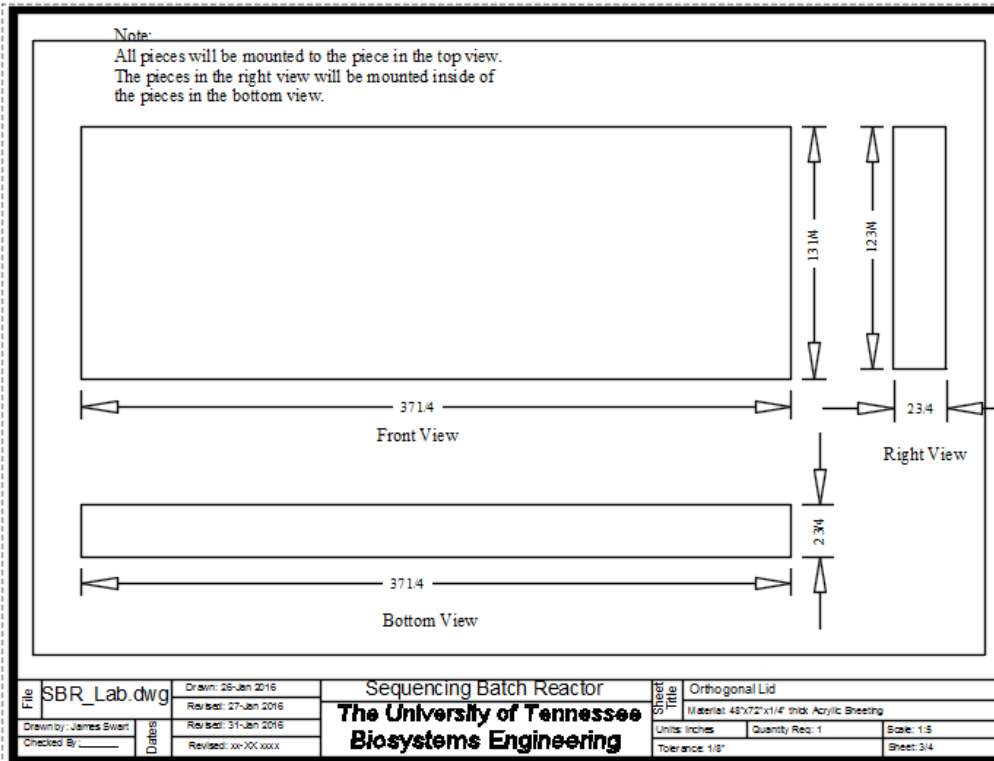
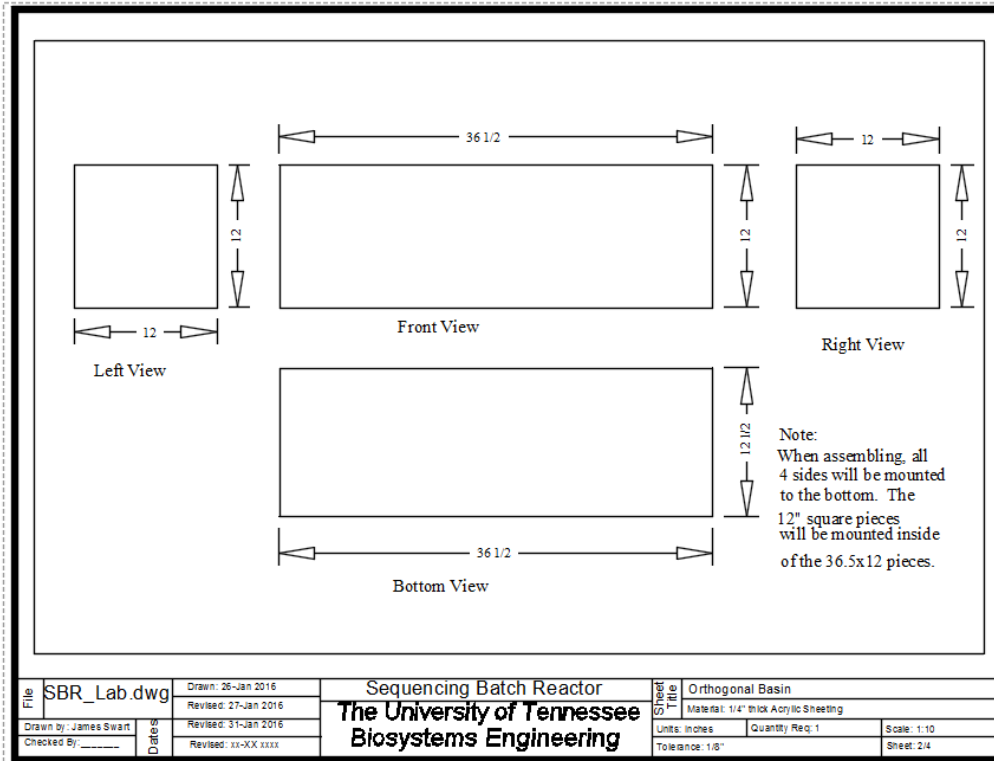

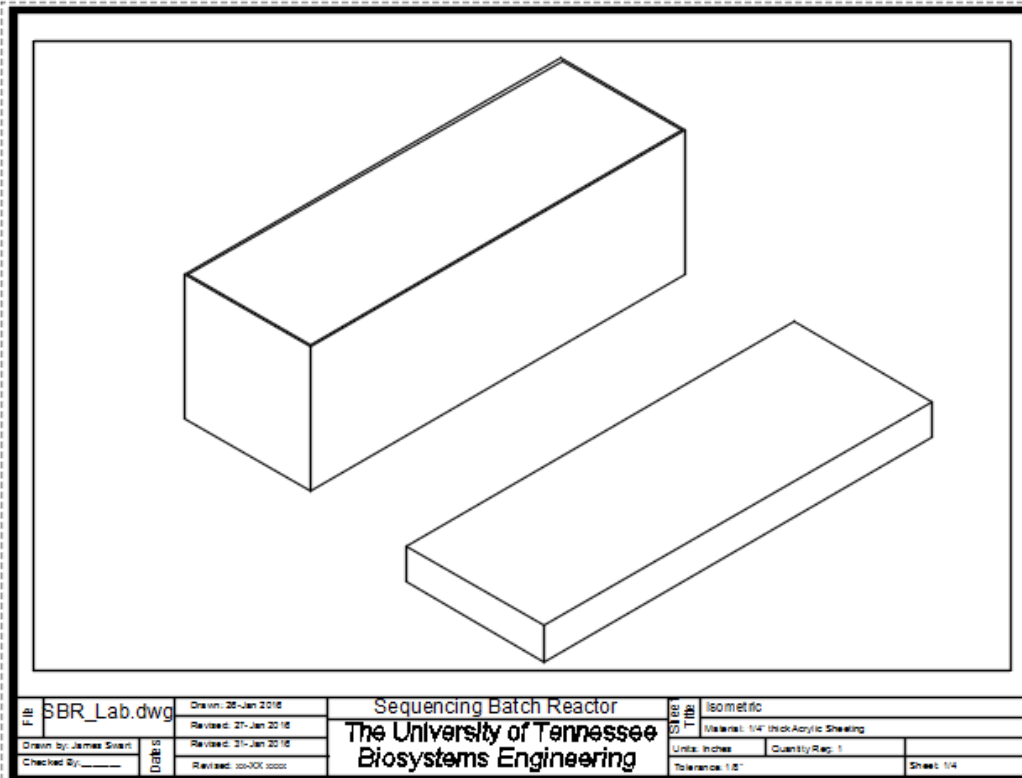
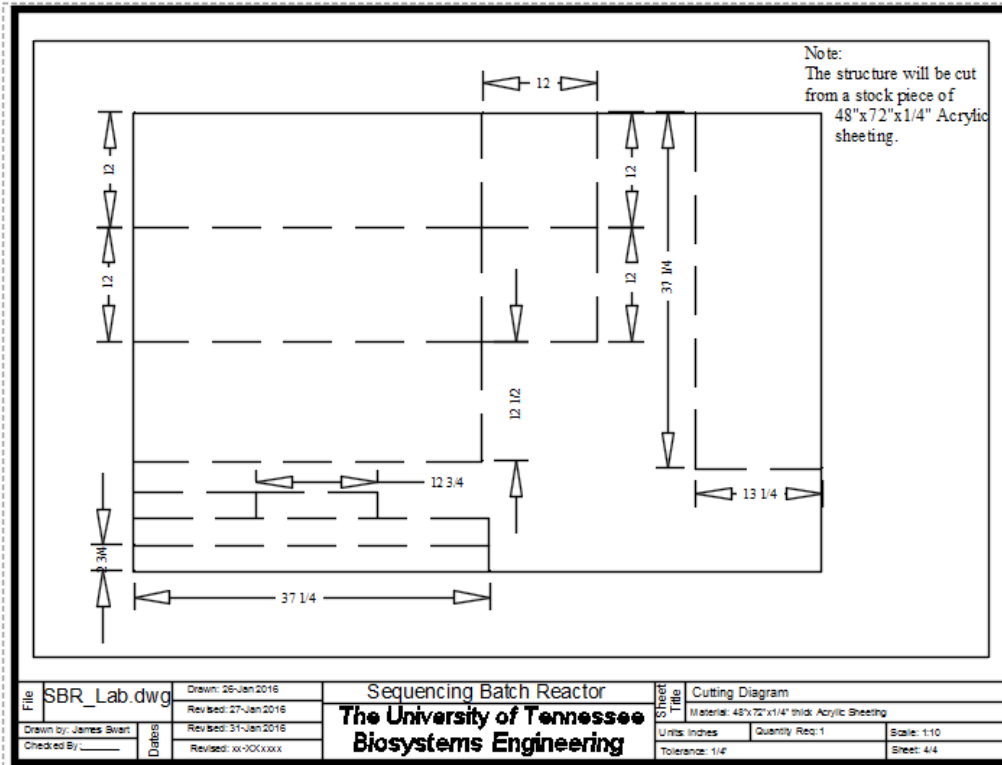

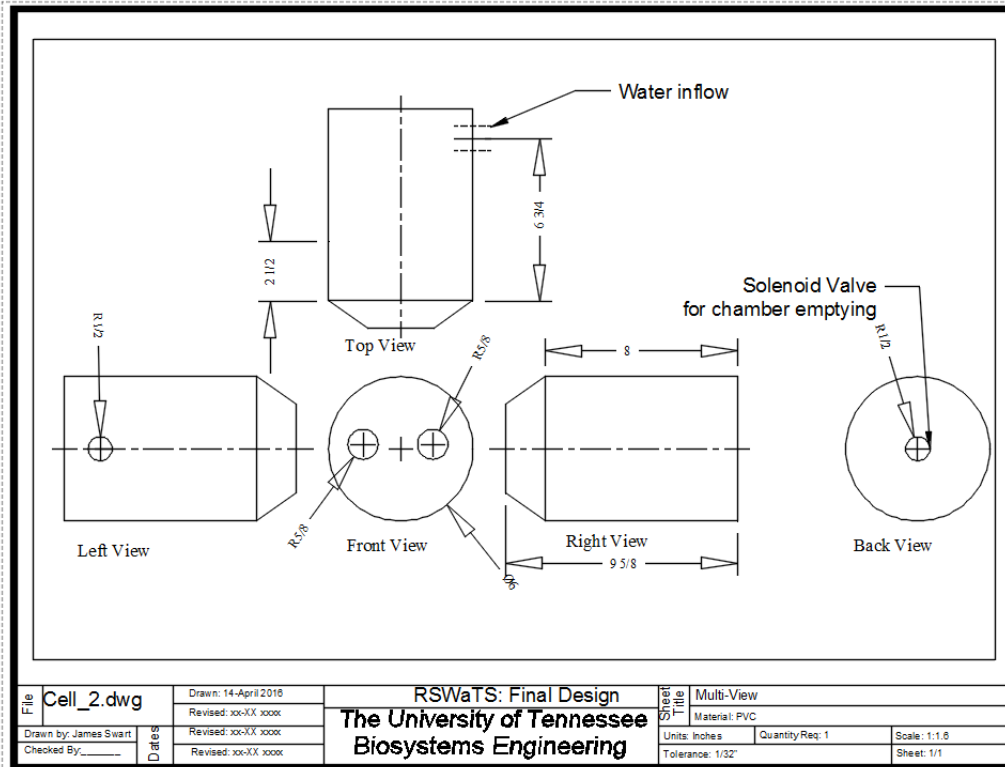
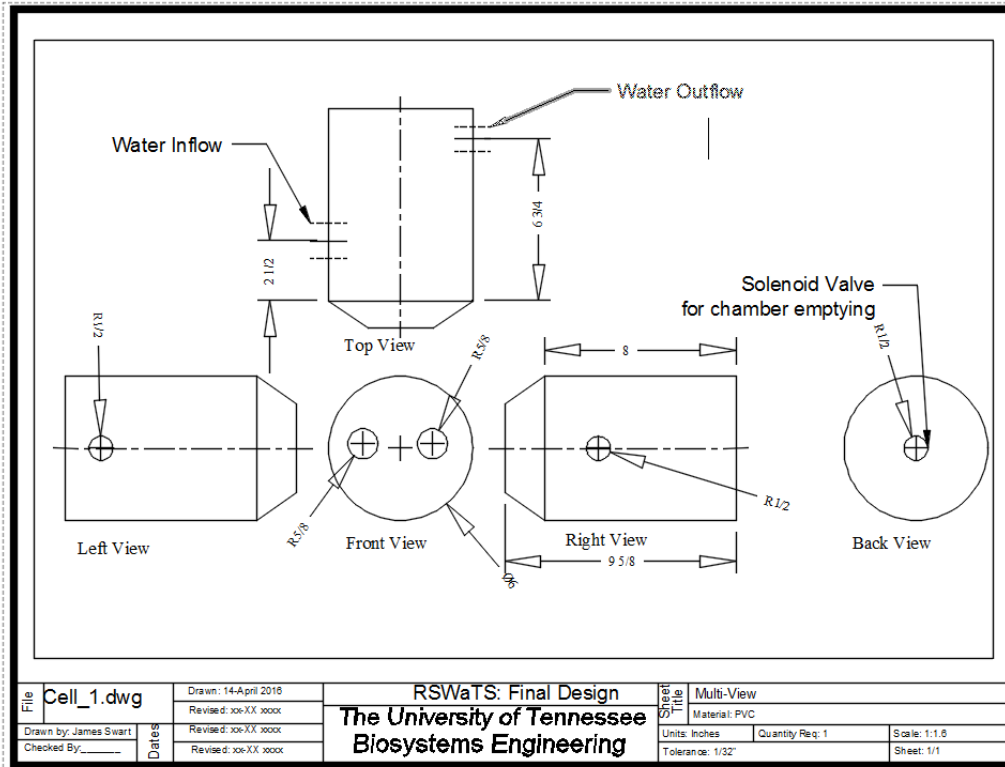

## A.2 Morph Charts for Justification of Choices

The following morph charts were developed to weigh the pros and cons of both secondary and tertiary treatment for the needs of the system.

Table 1. Morph chart for choosing optimal secondary treatment.

<b>Constraint</b>	<b>Sequencing Batch Reactor</b>	<b>Trickling Filter</b>	<b>Membrane Bioreactor</b>
Cost	1	3	2
Maintenance	1	3	2
Flexibility	1	3	2
Size	2	1	3
Suitability for Nitrogen	1	3	1
<b>Total</b>	<b>6</b>	<b>13</b>	<b>10</b>

Table 2. Morph chart for choosing optimal tertiary treatment.

<b>Constraint</b>	<b>Chlorination</b>	<b>UV Light</b>	<b>Ozone</b>
Cost	1	2	3
Bacteria Removal	2	1	2
Treatment Time	2	1	2
Size	2	1	3
Energy Consumption	1	2	3
Post Disinfection Treatment	3	1	2
<b>Total</b>	<b>11</b>	<b>8</b>	<b>15</b>

Using morph charts to compare similar options helps to narrow down which one will work the best. This method of comparison is not a one hundred percent guarantee that the method chosen will be the best in the end, but is a good indicator. Using the morph chart the secondary treatment was a Sequencing Batch Reactor, later to include Moving Bed Biofilm Reactors. In addition, for tertiary treatment, UV Light Disinfection was chosen.

### A.3 Pump Curves

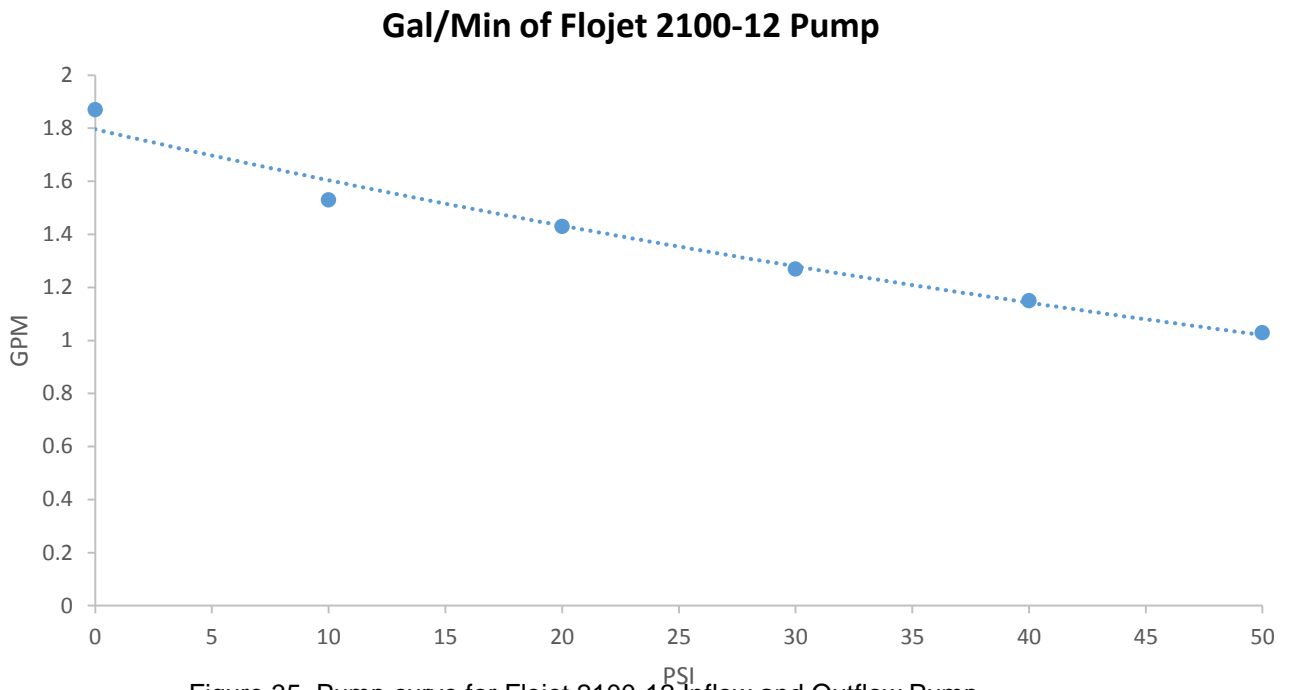

Figure 35. Pump curve for Flojet 2100-12 Inflow and Outflow Pump.

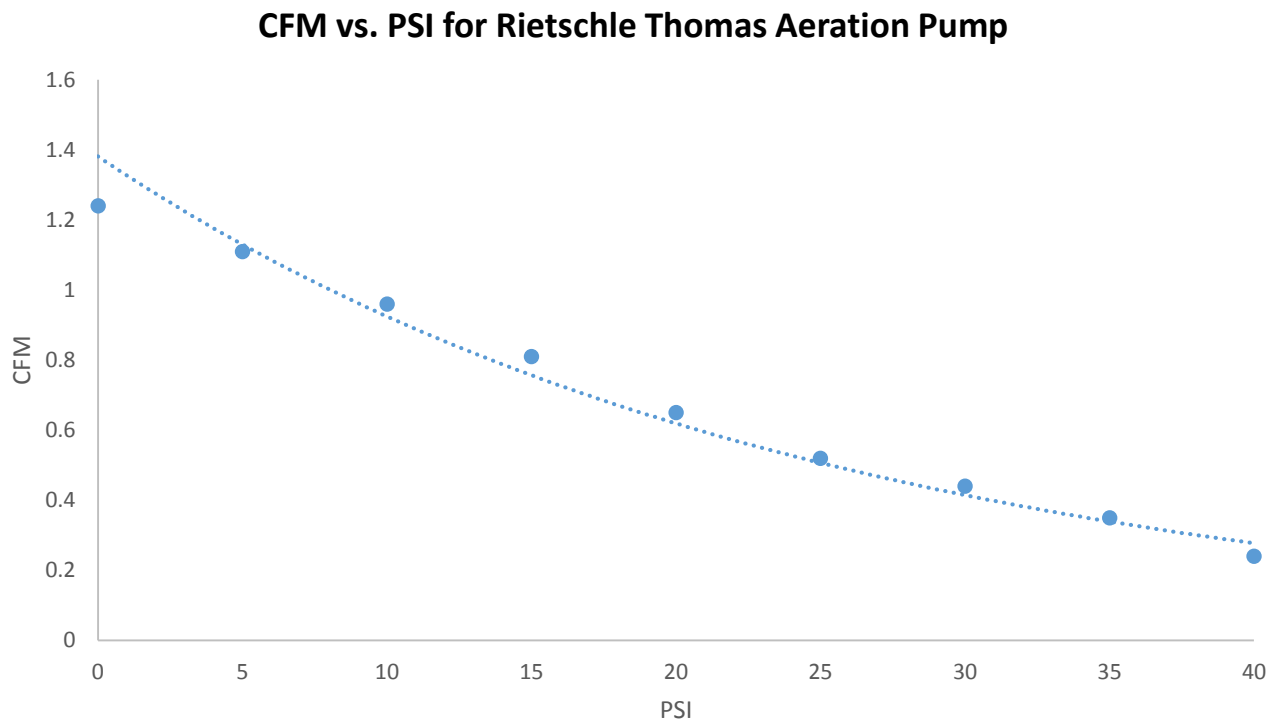

Figure 36. Pump curve for Rietschle Thomas Aeration Pump.

## A.4 Disinfection Curve

### SILVER SERIES DOSE FLOW CHART:

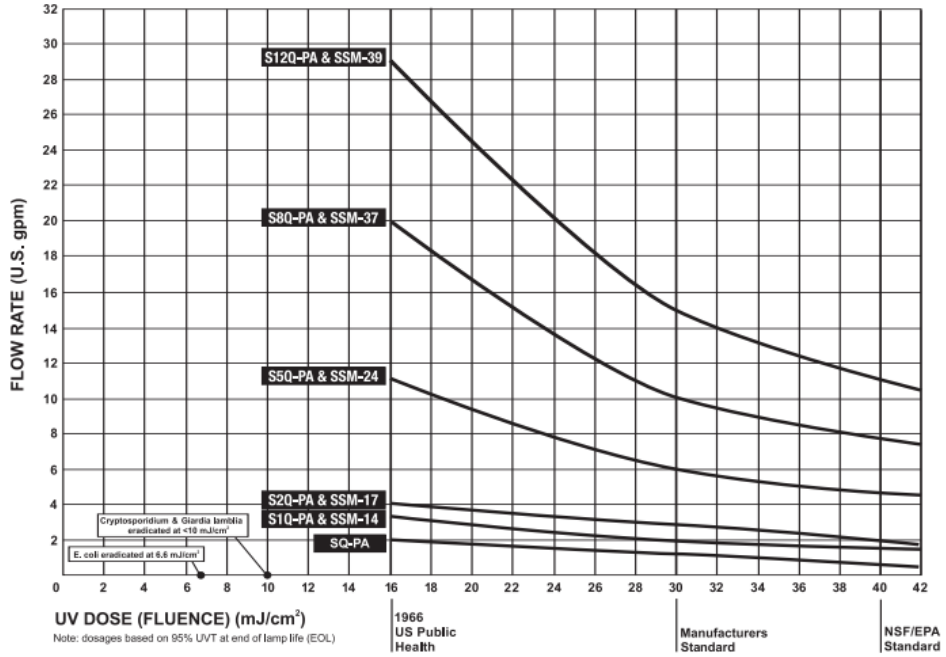

Figure 37. Disinfection curve for Sterilight Silver SSM-17.

## A.5 Calibration Curves



Figure 38. Nitrate exponential relationship.



Figure 39. Nitrate calibration curve.



Figure 40. Dissolved Oxygen calibration curve.

## A.6 Instrumentation and Controls

### Arduino Code -

```
#include <EEPROM.h>

const int FlowEQ = 2;
const int SBRLow = 3;
const int SBRhigh = 4;

const int Pump1 = 5;

const int SamplePump1 = 6;
const int SamplePump2 = 7;
const int Solenoid1 = A4;
const int Solenoid2 = A5;

const int AirPump = 8;

const int Pump2 = 9;

const int pHpower = 13;
const int DOpower = 12;
const int AmmoniumPower = 11;
const int NitratePower = 10;

const int pHsensor = A0;
const int DOSensor = A1;
const int AmmoniumSensor = A2;
const int NitrateSensor = A3;

float pHslope = -3.8459;
float pHintercept = 13.551;
float pH = 0;
float DOSlope = 3.6827;
float DOintercept = -1.0312;
float DO = 0;
float AmmoniumSlope = 0.1194;
float AmmoniumIntercept = 1.48;
float AmmoniumCount = 0;
float AmmoniumVoltage = 0;
float Ammonium = 0;
float AmmoniumCountNew = 0;
float AmmoniumVoltageNew = 0;
float AmmoniumNew = 0;
float AmmoniumOldI = 0;
float AmmoniumOldII = 0;
float AmmoniumCalcl = 0;
```

```
float AmmoniumCalcII = 0;
float NitrateSlope = -0.1325;
float NitrateIntercept = 2.1;
float NitrateCount = 0;
float NitrateVoltage = 0;
float Nitrate = 0;
float NitrateCountNew = 0;
float NitrateVoltageNew = 0;
float NitrateNew = 0;
float NitrateOld = 0;
float NitrateCalc = 0;
float TotalNitrate = 0;
float TIN = 0;
```

```
float e = 2.718281828459045235360287471352;
```

```
////////////////////////////////////
```

```
void setup()
{
  Serial.begin(250000);
  analogReference(DEFAULT);
  pinMode(FlowEQ, INPUT);
  pinMode(SBRlow, INPUT);
  pinMode(SBRhigh, INPUT);
  pinMode(Pump1, OUTPUT);
  pinMode(Pump2, OUTPUT);
  pinMode(SamplePump1, OUTPUT);
  pinMode(SamplePump2, OUTPUT);
  pinMode(Solenoid1, OUTPUT);
  pinMode(Solenoid2, OUTPUT);
  pinMode(AirPump, OUTPUT);
  pinMode(pHpower, OUTPUT);
  pinMode(DOpower, OUTPUT);
  pinMode(AmmoniumPower, OUTPUT);
  pinMode(NitratePower, OUTPUT);
  pinMode(pHsensor, INPUT);
  pinMode(DOsensor, INPUT);
  pinMode(AmmoniumSensor, INPUT);
  EEPROM.put(4, AmmoniumOldI);
  pinMode(NitrateSensor, INPUT);
  EEPROM.put(5, AmmoniumOldII);
  EEPROM.put(6, NitrateOld);
}
```

```
void loop()
{
  START();
}
```

```
//////////////////////////////////START//////////////////////////////////
```

```
void START()
{
  FlowEqualization();
}
```

```
//////////////////////////////////Flow Equalization//////////////////////////////////
```

```
void FlowEqualization()
{
  Serial.println("FLOW EQ filling");
  delay(1000);

  while (digitalRead(FlowEQ) == LOW) {}

  if (digitalRead(FlowEQ) == HIGH)
  {
    delay(1000);
    CheckSBR();
  }
}
```

```
//////////////////////////////////CHECK SBR//////////////////////////////////
```

```
void CheckSBR()
{
  while (digitalRead(SBRhigh) == LOW || digitalRead(SBRlow) == LOW)
  {
    Serial.println("SBR in current use");
    delay(1000);
  }

  if (digitalRead(SBRhigh) == HIGH && digitalRead(SBRlow) == HIGH)
  {
    Serial.println("SBR Empty");
    delay(1000);
    SBRfilling();
  }
}
```

```
//////////////////////////////////SBR FILLING//////////////////////////////////
```

```
void SBRfilling()
{
  while (digitalRead(SBRhigh) == HIGH)
  {
    Serial.println("SBR Filling");
  }
}
```

```

digitalWrite(Pump1, HIGH);
delay(1000);
Serial.println("Pump1 ON");
}

if (digitalRead(SBRhigh) == LOW)
{
digitalWrite(Pump1, LOW);
Serial.println("Pump1 OFF");
delay(1000);
SBRfull();
}
}

//////////////////////////////////SBR FULL//////////////////////////////////

void SBRfull()
{
Serial.println("SBR Full");
delay(1000);
SamplePumpsAmmonium();
}

//////////////////////////////////AMMONIUM SAMPLE PUMPS//////////////////////////////////

void SamplePumpsAmmonium()
{
delay(1000);
digitalWrite(SamplePump1, HIGH);
digitalWrite(SamplePump2, HIGH);
delay(40000);

digitalWrite(SamplePump1, LOW);
delay(1000);
AmmoniumState();
}

//////////////////////////////////AMMONIUM GATE//////////////////////////////////

void AmmoniumState()

{
//////////////////////////////////pH & Ammonium//////////////////////////////////

digitalWrite(pHpower, HIGH);
digitalWrite(AmmoniumPower, HIGH);
digitalWrite(NitratePower, LOW);
digitalWrite(DOpower, LOW);
delay(120000);

```

```
float pHcount = analogRead(pHsensor);
float pHvoltage = pHcount / 1023.0 * 5.0;
float pH = pHintercept + pHvoltage * pHslope;
Serial.print(pH);
Serial.print(" , ");
delay(5000);
```

```
float AmmoniumCountNew = analogRead(AmmoniumSensor);
float AmmoniumVoltageNew = AmmoniumCountNew / 1023.0 * 5.0;
float AmmoniumNew = pow(e, ((AmmoniumVoltageNew - AmmoniumIntercept) / AmmoniumSlope));
Serial.print(AmmoniumNew);
Serial.print(" , ");
delay(5000);
```

```
//////////////////////////////////PAUSE//////////////////////////////////
```

```
digitalWrite(pHpower, LOW);
digitalWrite(AmmoniumPower, LOW);
digitalWrite(NitratePower, LOW);
digitalWrite(DOpower, LOW);
delay(5000);
```

```
//////////////////////////////////DO & Nitrate//////////////////////////////////
```

```
digitalWrite(pHpower, LOW);
digitalWrite(AmmoniumPower, LOW);
digitalWrite(NitratePower, HIGH);
digitalWrite(DOpower, HIGH);
delay(120000);
```

```
float DOcount = analogRead(DOsensor);
float DOvoltage = DOcount / 1023.0 * 5.0;
float DO = DOvoltage * DOSlope + DOintercept;
Serial.print(DO);
Serial.print(" , ");
delay(5000);
```

```
float NitrateCount = analogRead(NitrateSensor);
float NitrateVoltage = NitrateCount / 1023.0 * 5.0;
float Nitrate = pow(e, ((NitrateVoltage - NitrateIntercept) / NitrateSlope));
Serial.println(Nitrate);
delay(5000);
```

```
//////////////////////////////////PAUSE//////////////////////////////////
```

```
digitalWrite(pHpower, LOW);
digitalWrite(AmmoniumPower, LOW);
digitalWrite(NitratePower, LOW);
```

```
digitalWrite(DOpower, LOW);
delay(5000);
```

```
//////////////////////////////////Ammonium Calculation//////////////////////////////////
```

```
Serial.print("AmmoniumNew: ");
Serial.println(AmmoniumNew);
float AmmoniumOldI = EEPROM.get(4, AmmoniumOldI);
Serial.print("AmmoniumOld: ");
Serial.println(AmmoniumOldI);
delay(3000);
AmmoniumCalcl = abs(AmmoniumNew - AmmoniumOldI);
Serial.println(AmmoniumCalcl);
delay(3000);
```

```
digitalWrite(Solenoid1, HIGH);
delay(30000);
```

```
digitalWrite(Solenoid1, LOW);
delay(2000);
```

```
AmmoniumOldI = AmmoniumNew;
delay(2000);
```

```
EEPROM.put(4, AmmoniumNew);
delay(2000);
```

```
if (AmmoniumCalcl > 1)
{
  delay(6000);
  SamplePumpsAmmonium();
}
```

```
if (AmmoniumCalcl < 1)
{
  delay(6000);
  SamplePumpsAmmoniumDoubleCheck();
}
}
```

```
//////////////////////////////////AMMONIUM DOUBLE CHECK//////////////////////////////////
```

```
//////////////////////////////////AMMONIUM SAMPLE PUMPS DOUBLE CHECK//////////////////////////////////
```

```
void SamplePumpsAmmoniumDoubleCheck()
{
  delay(1000);
  digitalWrite(SamplePump1, HIGH);
  digitalWrite(SamplePump2, HIGH);
```

```

delay(40000);

digitalWrite(SamplePump1, LOW);
delay(1000);
AmmoniumStateDoubleCheck();
}

//////////////////////////////////AMMONIUM GATE DOUBLE CHECK//////////////////////////////////

void AmmoniumStateDoubleCheck()
{

//////////////////////////////////pH & Ammonium//////////////////////////////////

Serial.println("Ammonium Double Check");
digitalWrite(pHpower, HIGH);
digitalWrite(AmmoniumPower, HIGH);
digitalWrite(NitratePower, LOW);
digitalWrite(DOpower, LOW);
delay(120000);

float pHcount = analogRead(pHsensor);
float pHvoltage = pHcount / 1023.0 * 5.0;
float pH = pHintercept + pHvoltage * pHslope;
Serial.print(pH);
Serial.print(" , ");
delay(5000);

float AmmoniumCountNew = analogRead(AmmoniumSensor);
float AmmoniumVoltageNew = AmmoniumCountNew / 1023.0 * 5.0;
float AmmoniumNew = pow(e, ((AmmoniumVoltageNew - AmmoniumIntercept) / AmmoniumSlope));
Serial.print(AmmoniumNew);
Serial.print(" , ");
delay(5000);

//////////////////////////////////PAUSE//////////////////////////////////

digitalWrite(pHpower, LOW);
digitalWrite(AmmoniumPower, LOW);
digitalWrite(NitratePower, LOW);
digitalWrite(DOpower, LOW);
delay(5000);

//////////////////////////////////DO & Nitrate//////////////////////////////////

digitalWrite(pHpower, LOW);
digitalWrite(AmmoniumPower, LOW);
digitalWrite(NitratePower, HIGH);
digitalWrite(DOpower, HIGH);

```

```
delay(120000);

float DOcount = analogRead(DOsensor);
float DOvoltage = DOcount / 1023.0 * 5.0;
float DO = DOvoltage * DOSlope + DOintercept;
Serial.print(DO);
Serial.print(" , ");
delay(5000);

float NitrateCount = analogRead(NitrateSensor);
float NitrateVoltage = NitrateCount / 1023.0 * 5.0;
float Nitrate = pow(e, ((NitrateVoltage - NitrateIntercept) / NitrateSlope));
Serial.println(Nitrate);
delay(5000);
```

////////////////////////////////PAUSE////////////////////////////////

```
digitalWrite(pHpower, LOW);
digitalWrite(AmmoniumPower, LOW);
digitalWrite(NitratePower, LOW);
digitalWrite(DOpower, LOW);
delay(5000);
```

////////////////////////////////Ammonium Calculation////////////////////////////////

```
Serial.print("AmmoniumNew: ");
Serial.println(AmmoniumNew);
float AmmoniumOldI = EEPROM.get(4, AmmoniumOldI);
Serial.print("AmmoniumOld: ");
Serial.println(AmmoniumOldI);
AmmoniumCalcl = abs(AmmoniumNew - AmmoniumOldI);
delay(3000);
Serial.println(AmmoniumCalcl);
delay(3000);
```

```
digitalWrite(Solenoid1, HIGH);
delay(30000);
```

```
digitalWrite(Solenoid1, LOW);
delay(2000);
```

```
AmmoniumOldI = AmmoniumNew;
delay(2000);
```

```
EEPROM.put(4, AmmoniumNew);
delay(2000);
```

```
if (AmmoniumCalcl > 1)
```

```

{
  delay(6000);
  SamplePumpsAmmonium();
}

if (AmmoniumCalcl < 1)
{
  delay(6000);
  SamplePumpsNitrate();
}
}

//////////////////////////////////NITRATE SAMPLE PUMPS//////////////////////////////////

void SamplePumpsNitrate()
{
  Serial.println("Nitrate Gate");
  digitalWrite(AirPump, HIGH);
  delay(1000);

  digitalWrite(SamplePump1, HIGH);
  digitalWrite(SamplePump2, HIGH);
  delay(40000);

  digitalWrite(SamplePump1, LOW);
  delay(1000);
  NitrateState();
}

//////////////////////////////////NITRATE GATE//////////////////////////////////

void NitrateState()

{
  ////////////////////////////////////pH & Ammonium//////////////////////////////////

  Serial.println("Nitrate State");
  digitalWrite(pHpower, HIGH);
  digitalWrite(AmmoniumPower, HIGH);
  digitalWrite(NitratePower, LOW);
  digitalWrite(DOpower, LOW);
  delay(120000);

  float pHcount = analogRead(pHSensor);
  float pHvoltage = pHcount / 1023.0 * 5.0;
  float pH = pHintercept + pHvoltage * pHslope;
  Serial.print(pH);
  Serial.print(" , ");
  delay(5000);
}

```

```
float AmmoniumCountNew = analogRead(AmmoniumSensor);
float AmmoniumVoltageNew = AmmoniumCountNew / 1023.0 * 5.0;
float AmmoniumNew = pow(e, ((AmmoniumVoltageNew - AmmoniumIntercept) / AmmoniumSlope));
Serial.print(AmmoniumNew);
Serial.print(" , ");
delay(5000);
```

```
//////////////////////////////////PAUSE//////////////////////////////////
```

```
digitalWrite(pHpower, LOW);
digitalWrite(AmmoniumPower, LOW);
digitalWrite(NitratePower, LOW);
digitalWrite(DOpower, LOW);
delay(5000);
```

```
//////////////////////////////////DO & Nitrate//////////////////////////////////
```

```
digitalWrite(pHpower, LOW);
digitalWrite(AmmoniumPower, LOW);
digitalWrite(NitratePower, HIGH);
digitalWrite(DOpower, HIGH);
delay(120000);
```

```
float DOcount = analogRead(DOsensor);
float DOvoltage = DOcount / 1023.0 * 5.0;
float DO = DOvoltage * DOSlope + DOintercept;
Serial.print(DO);
Serial.print(" , ");
delay(5000);
```

```
float NitrateCount = analogRead(NitrateSensor);
float NitrateVoltage = NitrateCount / 1023.0 * 5.0;
float Nitrate = pow(e, ((NitrateVoltage - NitrateIntercept) / NitrateSlope));
Serial.println(Nitrate);
delay(5000);
```

```
//////////////////////////////////PAUSE//////////////////////////////////
```

```
digitalWrite(pHpower, LOW);
digitalWrite(AmmoniumPower, LOW);
digitalWrite(NitratePower, LOW);
digitalWrite(DOpower, LOW);
delay(5000);
```

```
//////////////////////////////////Nitrate Calculation//////////////////////////////////
```

```
Serial.print("AmmoniumNew: ");
Serial.println(AmmoniumNew);
```

```

float AmmoniumOldII = EEPROM.get(5, AmmoniumOldII);
Serial.print("AmmoniumOld: ");
Serial.println(AmmoniumOldII);
delay(3000);
AmmoniumCalcII = abs(AmmoniumNew - AmmoniumOldII);
Serial.println(AmmoniumCalcII);
delay(3000);

digitalWrite(Solenoid1, HIGH);
delay(30000);

digitalWrite(Solenoid1, LOW);
delay(2000);

AmmoniumOldII = AmmoniumNew;
delay(2000);

EEPROM.put(5, AmmoniumNew);
delay(2000);

if (AmmoniumCalcII > 1)
{
  delay(6000);
  SamplePumpsNitrate();
}

if (AmmoniumCalcII < 1)
{
  delay(6000);
  SamplePumpsNitrateDoubleCheck();
}
}

//////////////////////////////////NITRATE DOUBLE CHECK//////////////////////////////////

//////////////////////////////////NITRATE SAMPLE PUMPS DOUBLE CHECK//////////////////////////////////

void SamplePumpsNitrateDoubleCheck()
{
  Serial.println("Nitrate Gate Double Check");
  digitalWrite(AirPump, HIGH);
  delay(1000);

  digitalWrite(SamplePump1, HIGH);
  digitalWrite(SamplePump2, HIGH);
  delay(40000);

  digitalWrite(SamplePump1, LOW);
  delay(1000);
}

```

```

    NitrateStateDoubleCheck();
}

//////////////////////////////////NITRATE GATE DOUBLE CHECK//////////////////////////////////

void NitrateStateDoubleCheck()

{
    ////////////////////////////////////pH & Ammonium//////////////////////////////////

    digitalWrite(pHpower, HIGH);
    digitalWrite(AmmoniumPower, HIGH);
    digitalWrite(NitratePower, LOW);
    digitalWrite(DOpower, LOW);
    delay(120000);

    float pHcount = analogRead(pHsensor);
    float pHvoltage = pHcount / 1023.0 * 5.0;
    float pH = pHintercept + pHvoltage * pHslope;
    Serial.print(pH);
    Serial.print(" , ");
    delay(5000);

    float AmmoniumCountNew = analogRead(AmmoniumSensor);
    float AmmoniumVoltageNew = AmmoniumCountNew / 1023.0 * 5.0;
    float AmmoniumNew = pow(e, ((AmmoniumVoltageNew - AmmoniumIntercept) / AmmoniumSlope));
    Serial.print(AmmoniumNew);
    Serial.print(" , ");
    delay(5000);

    ////////////////////////////////////PAUSE//////////////////////////////////

    digitalWrite(pHpower, LOW);
    digitalWrite(AmmoniumPower, LOW);
    digitalWrite(NitratePower, LOW);
    digitalWrite(DOpower, LOW);
    delay(5000);

    ////////////////////////////////////DO & Nitrate//////////////////////////////////

    digitalWrite(pHpower, LOW);
    digitalWrite(AmmoniumPower, LOW);
    digitalWrite(NitratePower, HIGH);
    digitalWrite(DOpower, HIGH);
    delay(120000);

    float DOcount = analogRead(DOsensor);
    float DOvoltage = DOcount / 1023.0 * 5.0;

```

```

float DO = DOvoltage * DOSlope + DOintercept;
Serial.print(DO);
Serial.print(" , ");
delay(5000);

float NitrateCount = analogRead(NitrateSensor);
float NitrateVoltage = NitrateCount / 1023.0 * 5.0;
float Nitrate = pow(e, ((NitrateVoltage - NitrateIntercept) / NitrateSlope));
Serial.println(Nitrate);
delay(5000);

```

```

////////////////////////////////PAUSE////////////////////////////////

```

```

digitalWrite(pHpower, LOW);
digitalWrite(AmmoniumPower, LOW);
digitalWrite(NitratePower, LOW);
digitalWrite(DOpower, LOW);
delay(5000);

```

```

////////////////////////////////Nitrate Calculation////////////////////////////////

```

```

Serial.print("AmmoniumNew: ");
Serial.println(AmmoniumNew);
float AmmoniumOldII = EEPROM.get(5, AmmoniumOldII);
Serial.print("AmmoniumOld: ");
Serial.println(AmmoniumOldII);
delay(3000);
AmmoniumCalcII = abs(AmmoniumNew - AmmoniumOldII);
Serial.println(AmmoniumCalcII);
delay(3000);

```

```

digitalWrite(Solenoid1, HIGH);
delay(30000);

```

```

digitalWrite(Solenoid1, LOW);
delay(2000);

```

```

AmmoniumOldII = AmmoniumNew;
delay(2000);

```

```

EEPROM.put(5, AmmoniumNew);
delay(2000);

```

```

if (AmmoniumCalcII > 1)
{
  delay(6000);
  SamplePumpsNitrate();
}

```

```

if (AmmoniumCalcII < 1)
{
  delay(6000);
  SamplePumpsNitrateDrop();
}
}

//////////////////////////////////NITRATE DROP SAMPLE PUMPS//////////////////////////////////

void SamplePumpsNitrateDrop()
{
  Serial.println("Total Nitrogen");
  digitalWrite(AirPump, LOW);
  delay(1000);

  digitalWrite(SamplePump1, HIGH);
  digitalWrite(SamplePump2, HIGH);
  delay(40000);

  digitalWrite(SamplePump1, LOW);
  delay(1000);

  NitrateDrop();
}

//////////////////////////////////NITRATE DROP GATE//////////////////////////////////

void NitrateDrop()
{
  ////////////////////////////////////pH & Ammonium//////////////////////////////////

  digitalWrite(pHpower, HIGH);
  digitalWrite(AmmoniumPower, HIGH);
  digitalWrite(NitratePower, LOW);
  digitalWrite(DOpower, LOW);
  delay(120000);

  float pHcount = analogRead(pHSensor);
  float pHvoltage = pHcount / 1023.0 * 5.0;
  float pH = pHintercept + pHvoltage * pHslope;
  Serial.print(pH);
  Serial.print(" , ");
  delay(5000);

  float AmmoniumCountNew = analogRead(AmmoniumSensor);
  float AmmoniumVoltageNew = AmmoniumCountNew / 1023.0 * 5.0;
  float AmmoniumNew = pow(e, ((AmmoniumVoltageNew - AmmoniumIntercept) / AmmoniumSlope));
  Serial.print(AmmoniumNew);
}

```

```
Serial.print(" , ");
delay(5000);
```

```
//////////////////////////////////PAUSE//////////////////////////////////
```

```
digitalWrite(pHpower, LOW);
digitalWrite(AmmoniumPower, LOW);
digitalWrite(NitratePower, LOW);
digitalWrite(DOpower, LOW);
delay(5000);
```

```
//////////////////////////////////DO & Nitrate//////////////////////////////////
```

```
digitalWrite(pHpower, LOW);
digitalWrite(AmmoniumPower, LOW);
digitalWrite(NitratePower, HIGH);
digitalWrite(DOpower, HIGH);
delay(120000);
```

```
float DOcount = analogRead(DOsensor);
float DOvoltage = DOcount / 1023.0 * 5.0;
float DO = DOvoltage * DOSlope + DOintercept;
Serial.print(DO);
Serial.print(" , ");
delay(5000);
```

```
float NitrateCountNew = analogRead(NitrateSensor);
float NitrateVoltageNew = NitrateCountNew / 1023.0 * 5.0;
float NitrateNew = pow(e, ((NitrateVoltageNew - NitrateIntercept) / NitrateSlope));
Serial.println(NitrateNew);
delay(5000);
```

```
//////////////////////////////////PAUSE//////////////////////////////////
```

```
digitalWrite(pHpower, LOW);
digitalWrite(AmmoniumPower, LOW);
digitalWrite(NitratePower, LOW);
digitalWrite(DOpower, LOW);
delay(5000);
```

```
//////////////////////////////////Nitrate DROP Calculation//////////////////////////////////
```

```
Serial.print("NitrateNew: ");
Serial.println(NitrateNew);
delay(2000);
float NitrateOld = EEPROM.get(6, NitrateOld);
Serial.print("NitrateOld: ");
Serial.println(NitrateOld);
delay(2000);
```

```
NitrateCalc = abs(NitrateNew - NitrateOld);  
Serial.println(NitrateCalc);  
delay(2000);
```

```
digitalWrite(Solenoid1, HIGH);  
delay(30000);
```

```
digitalWrite(Solenoid1, LOW);  
delay(2000);
```

```
NitrateOld = NitrateNew;  
delay(2000);
```

```
EEPROM.put(6, NitrateNew);  
delay(2000);
```

```
if (NitrateCalc > 1)  
{  
  delay(6000);  
  SamplePumpsNitrateDrop();  
}
```

```
if (NitrateCalc < 1)  
{  
  delay(6000);  
  SamplePumpsTN();  
}  
}
```

```
////////////////////////////////FINAL CHECK before DISCHARGE sample pumps////////////////////////////////
```

```
void SamplePumpsTN()  
{  
  Serial.println("Total Nitrogen");  
  delay(1000);  
  digitalWrite(SamplePump1, HIGH);  
  digitalWrite(SamplePump2, HIGH);  
  delay(40000);  
  
  digitalWrite(SamplePump1, LOW);  
  delay(1000);  
  
  FINALCHECK();  
}
```

```
////////////////////////////////FINAL CHECK before DISCHARGE////////////////////////////////
```

```
void FINALCHECK()  
{
```

```
////////////////////////////////pH & Ammonium////////////////////////////////
```

```
digitalWrite(pHpower, HIGH);  
digitalWrite(AmmoniumPower, HIGH);  
digitalWrite(NitratePower, LOW);  
digitalWrite(DOpower, LOW);  
delay(120000);
```

```
float pHcount = analogRead(pHSensor);  
float pHvoltage = pHcount / 1023.0 * 5.0;  
float pH = pHintercept + pHvoltage * pHslope;  
Serial.print(pH);  
Serial.print(" , ");  
delay(5000);
```

```
float AmmoniumCount = analogRead(AmmoniumSensor);  
float AmmoniumVoltage = AmmoniumCount / 1023.0 * 5.0;  
float Ammonium = pow(e, ((AmmoniumVoltage - AmmoniumIntercept) / AmmoniumSlope));  
Serial.print(Ammonium);  
Serial.print(" , ");  
delay(5000);
```

```
////////////////////////////////PAUSE////////////////////////////////
```

```
digitalWrite(pHpower, LOW);  
digitalWrite(AmmoniumPower, LOW);  
digitalWrite(NitratePower, LOW);  
digitalWrite(DOpower, LOW);  
delay(5000);
```

```
////////////////////////////////DO & Nitrate////////////////////////////////
```

```
digitalWrite(pHpower, LOW);  
digitalWrite(AmmoniumPower, LOW);  
digitalWrite(NitratePower, HIGH);  
digitalWrite(DOpower, HIGH);  
delay(120000);
```

```
float DOcount = analogRead(DOSensor);  
float DOvoltage = DOcount / 1023.0 * 5.0;  
float DO = DOvoltage * DOSlope + DOintercept;  
Serial.print(DO);  
Serial.print(" , ");  
delay(5000);
```

```
float NitrateCount = analogRead(NitrateSensor);  
float NitrateVoltage = NitrateCount / 1023.0 * 5.0;  
float Nitrate = pow(e, ((NitrateVoltage - NitrateIntercept) / NitrateSlope));  
Serial.println(Nitrate);
```

```
delay(5000);
```

```
////////////////////////////////PAUSE////////////////////////////////
```

```
digitalWrite(pHpower, LOW);  
digitalWrite(AmmoniumPower, LOW);  
digitalWrite(NitratePower, LOW);  
digitalWrite(DOpower, LOW);  
delay(5000);
```

```
////////////////////////////////Final Gate////////////////////////////////
```

```
TIN = Ammonium + Nitrate;  
//Serial.println(TN);  
delay(10000);
```

```
if (pH >= 6 && pH <= 9 && DO <= 6 && TIN <= 4)
```

```
{  
  digitalWrite(Solenoid1, HIGH);
```

```
  delay(30000);
```

```
  digitalWrite(Solenoid1, LOW);  
  delay(10000);  
  EmptySBRI();
```

```
}
```

```
else
```

```
{  
  digitalWrite(Solenoid1, HIGH);  
  delay(30000);  
  digitalWrite(Solenoid1, LOW);  
  delay(10000);  
  SamplePumpsNitrateDrop();
```

```
}
```

```
}
```

```
////////////////////////////////Empty SBR I////////////////////////////////
```

```
void EmptySBRI()
```

```
{
```

```
  Serial.println("Empty");  
  digitalWrite(SamplePump2, LOW);  
  delay(1000);
```

```
  digitalWrite(Solenoid2, HIGH);  
  delay(1000);
```

```
  while (digitalRead(SBRlow) == LOW && digitalRead(SBRhigh) == LOW)
```

```
  {
```

```

    delay(1000);
    digitalWrite(Pump2, HIGH);
}

if (digitalRead(SBRlow) == LOW && digitalRead(SBRhigh) == HIGH)
{
    digitalWrite(Solenoid2, LOW);
    delay(1000);
    EmptySBRII();
}
}

/////////////////////////////////Empty SBR II/////////////////////////////////

void EmptySBRII()
{
    while (digitalRead(SBRlow) == LOW)
    {
        delay(1000);
        digitalWrite(Pump2, HIGH);
    }

    if (digitalRead(SBRlow) == HIGH)
    {
        delay(1000);
        digitalWrite(Pump2, LOW);
        delay(1000);
        FlowEqualization();
    }
}
}

```

Python Code -

```

import serial # import Serial Library
import numpy # Import numpy
import matplotlib.pyplot as plt #import matplotlib library
from drawnow import *

from openpyxl import Workbook
from openpyxl.compat import range
from openpyxl.cell import get_column_letter
import xlswriter

NH4ArrayLiveGraph = []
NH4ArrayExcel = []

NO3ArrayLiveGraph = []
NO3ArrayExcel = []

```

```
ArduinoSensorData = serial.Serial('com5', 115200) # Creating our serial object named arduinoData
plt.ion() #Tell matplotlib you want interactive mode to plot live data
```

```
def plotNH4andNO3():
    plt.title('Ammonium and Nitrate vs. Time')
    plt.ylim(0, 40)
    plt.grid(True)
    plt.ylabel('Ammonium Concentration (mg/L)')
    plt.xlabel('Time')
    plt.plot(NH4ArrayLiveGraph, 'go', label = 'NH4 Conc. ')
    plt.legend(loc = 'upper left')

    plt2 = plt.twinx()
    plt2.ylim(0, 40)
    plt2.set_ylabel('Nitrate Concentration (mg/L)')
    plt2.plot(NO3ArrayLiveGraph, 'co', label = 'NO3 Conc. ')
    plt2.legend(loc = 'upper right')
```

```
while True: # While loop that loops forever
    while (ArduinoSensorData.inWaiting()==0): # Wait here until there is data
        pass #do nothing
    ArduinoString = ArduinoSensorData.readline() #Read the line of text from the serial port
    print ArduinoString
    SensorDataArray = ArduinoString.split(',')
    NH4float = float(SensorDataArray[2])
    NO3float = float(SensorDataArray[3])

    NH4ArrayLiveGraph.append(NH4float)
    NO3ArrayLiveGraph.append(NO3float)
    drawnow(plotNH4andNO3)
    plt.pause(0.00001)

    NH4list = list(SensorDataArray[2])
    NO3list = list(SensorDataArray[3])

    NH4listjoin = ".join(NH4list)
    NO3listjoin = ".join(NO3list)

    NH4ArrayExcel.append(NH4listjoin)
    CorrectedNH4ArrayExcel = [[i.replace('\r\n','') for i in NH4ArrayExcel]]
    NO3ArrayExcel.append(NO3listjoin)
    CorrectedNO3ArrayExcel = [[i.replace('\r\n','') for i in NO3ArrayExcel]]

    workbook = xlswriter.Workbook('AmmoniumNitrateData.xlsx')
    worksheet1 = workbook.add_worksheet()
    worksheet2 = workbook.add_worksheet()

    row = 1
```

```
for col, data in enumerate(CorrectedNH4ArrayExcel):  
    worksheet1.write_column(row, col, data)
```

```
for col, data in enumerate(CorrectedNO3ArrayExcel):  
    worksheet2.write_column(row, col, data)
```

```
workbook.close()
```

## A.7 Biosystems 104 Student Apprentice Contribution

1. Each individually designed a stand for the Sequencing Batch Reactor
2. Collaborated to decide what the final design for the stand would be
3. Drafted the design in AutoCAD
4. Build the final stand design

Figure 41. (right) The isometric view of the sequencing batch reactor.

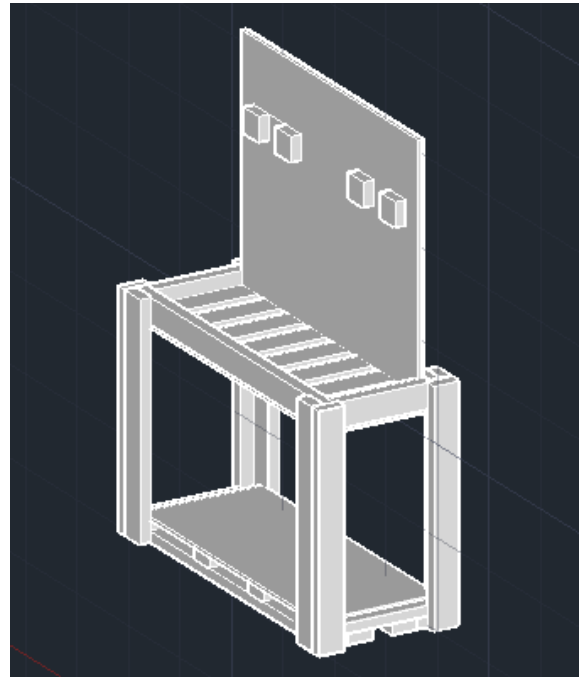

Figure 42. (bottom) Biosystems 104 Student Apprentices: Cabot Anderson, Taylor Spivey, Topher Keller, Luke Martin, and Patrick Rimer.

