

Economic Report on Vanadium Redox Flow Battery with Optimization of Flow Rate

CBE 488

Dr. Counce

4/15/13

Kevin Spellman

Kendrick Stiles

Ian Little

Table of Contents:

Introduction.....	3
Synthesis Information for VRB (EP 1).....	5
Input/ Output Analysis (EP 2).....	8
Optimization.....	9
Power Capacity Analysis (EP 3).....	15
Energy Capacity Analysis (EP 4).....	17
Balance of Plant Analysis (EP 5).....	18
Capital Investment Analysis (EP 6).....	19
Conclusions.....	20
Appendices	21
References	41

Introduction

The purpose of this report is to provide a detailed analysis on the economic feasibility of the insertion of Vanadium Redox Flow Batteries (VRFBs) into the electrical power grid. VRFBs could be beneficial to the power grid for two primary reasons. The initial economic studies (Moore 2012) into VRFB technology as a source of energy storage were based on the huge inefficiency in modern power grids. Currently, the grid is designed to meet production at all times based on the current needs. Thus, power production must currently be able to meet peak power need. However, if a smarter grid were created, a smaller constant production rate would be used and in off-peak times energy would be stored for peak need. Thus, the capital cost of power production would be significantly cheaper as several plants would no longer be necessary. Energy storage technology, such as VRFBs, would need to be implemented into the grid for a smarter and more efficient electrical grid to be realized. Thus, this report compiles the economic feasibility of VRFBs by charging them at off peak electricity rates and discharging them during peak rates.

However, due to changing policies in electrical sources, the use of VRFBs in the electrical grid will be necessary regardless of the economic feasibility. As the grid continues to rely on more and more sources of clean energy inconsistencies in electrical production by wind and solar power will create a necessity for large-scale energy storage. Thus, regardless of the economic outcome, the implementation of the design proposed in the report could be necessary in order to maintain stability in the grid when wind and solar electrical production cease due to the reliance of environmental conditions on electrical production.

The design objectives are to provide a study level design and analysis of a 12 MW VRFB. The base case of operation will be provided below in table one.

Table 1

Base case design information

1. Aqueous solutions of 1 Molar Vanadium/ 5 Molar Sulfuric Acid
2. Power Capacity= 12 MW
3. Cost of Membrane (Nafion 115) to be provided
4. All costs are to be estimated in 2012 dollars (CE Index = 575.4)
5. Selling cost of electricity is \$0.1576/kWh (EPB)
6. Purchased Electrical Cost energy is \$0.0541/ kWh (EPB)
7. One complete Charge/ Discharge cycle is assumed to take 24 hours
8. Optimized liquid flow rate to stack or half stack is to be determined

Results of this study are to be provided in a formal design report as follows.

Synthesis Information for the VPN (EP1)

Figure 1 (below) shows a simple schematic of a vanadium redox flow battery. A vanadium redox flow system requires two vanadium solutions, one containing a mixture of V^{2+} and V^{3+} and one containing VO^{2+} and VO_2^+ . Vanadium has the ability to exist in 4 different oxidation states; the vanadium ions VO^{2+} and VO_2^+ are actually vanadium oxide ions (respectively VO^{2+} and VO_2^+) (Blanc and Rufer, p. 334).

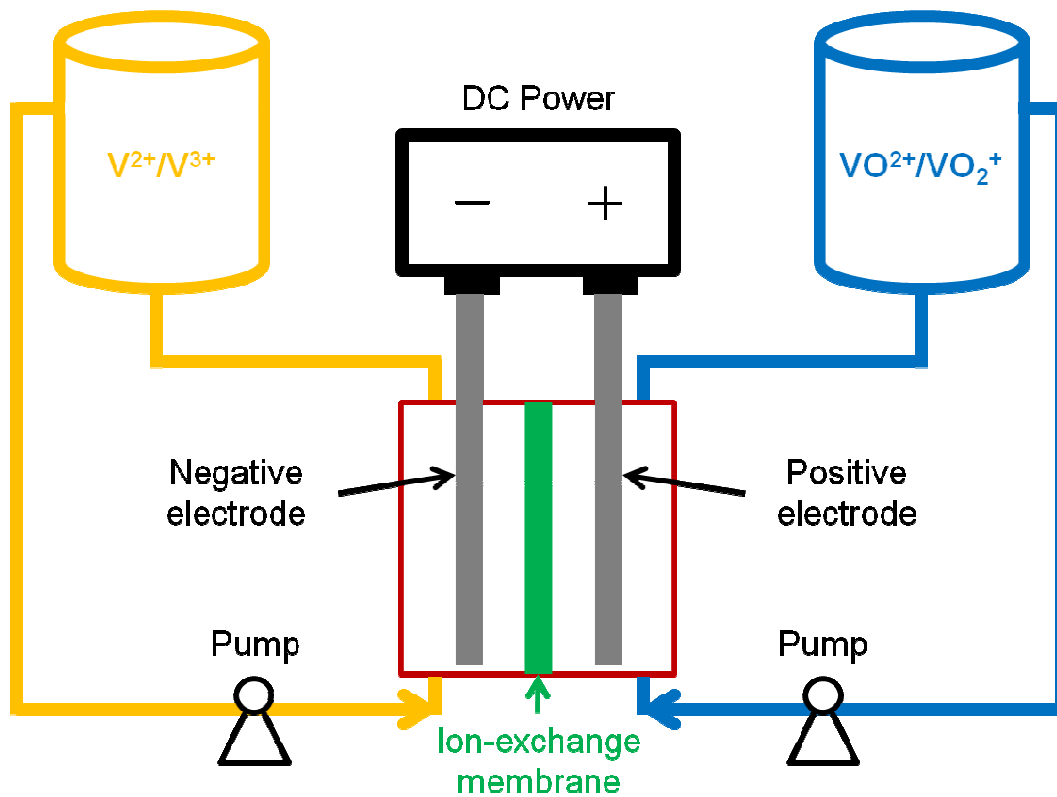
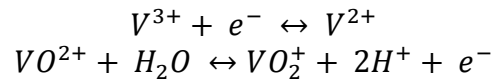

Figure 1: Simple schematic of Vanadium Redox Flow Battery. Image courtesy of large.stanford.edu.

In essence, a vanadium redox flow battery acts as an extremely large, rechargeable battery. While electricity is being generated, the battery is charged, with the following forward reactions taking place at the anode and cathode, respectively:



When discharging, the reverse of these two reactions takes place. As with any battery, electric current is produced (during discharge) when electrons travel from the negative anode to the positive cathode. In a flow battery, however, the two separate vanadium solutions are pumped across opposite sides of an ion exchange membrane, which allows for the flow of hydrogen ions as they are produced in either half-cell of the battery.

The design variable that this process will examine is the flow rate of vanadium solution delivered to each cell. As the operating voltage for each cell is dependent upon the lowest voltage across each membrane, higher flow rates will raise the voltage in areas close to the cell output (where voltage will be lowest) by reducing the accumulation of discharge products (V^{3+} and VO^{2+}) on each side of the cell membrane. Greater flow rates, however, also require higher generation energies. Therefore, this project's purpose will be to determine a flow rate that optimizes power production versus the requisite power consumption for pumping.

While power output and consumption are the primary economic drivers of a vanadium redox flow battery, other factors, such as equipment and materials, are also important considerations. In order to construct each cell, current collectors, carbon felt, and a membrane permeable to protons are needed, as well as vanadium pentoxide and sulfuric acid, which is used to create the vanadium solutions. Table 2 (appendix C.1) describes these costs (Moore p.241).

Another economic concern is the price at which power can be bought and sold. Using the power prices from EPB Power Company's website (www.epb.net), the price of input power (needed to charge the battery) and output power (discharged by the battery) seen in Table 3 (appendix C.1) were generated.

Physical characteristics of the system, such as the operating temperature and molarity of solutions, also need to be established. Choices in materials for the heat exchangers and tanks are similarly decided. For the tanks, PVC is used, as it represents a cost effective material that is resistant to acid corrosion (according to the PVC supply website www.usplastic.com). Owing to its high thermal conductivity and resistance to corrosion, high nickel steel will be utilized for the heat exchanger (according to the steel supply website www.regentsteel.net). Tables 4 and 5 (appendix C.1) delineate these characteristics.

Input/Output Analysis (EP2)

Input/Output analysis is based solely upon simple algebraic equations that describe the input and output of the system. In this case, the input is the cost of power bought, and the output is the cost of power sold. This model allows for the maximum profit potential, as all processing costs are ignored. Utilizing peak and off-peak power cost rates, the power bought will be during the cheaper, off-peak periods while the power sold will be during the more expensive peak periods, maximizing profit. The numbers generated for the peak and off-peak rates are based upon the rates given by the EPB Power Company, a company that provides rates comparable to those throughout the United States. For the charging and discharging energy to be calculated, however, electrical efficiency for the system must be calculated (see Appendix A). Once the electrical efficiency has been calculated, the input/output profit is then compared against a variable, in this case number of cycles of charge and discharge per year, which is illustrated in Figure 3 (Appendix C.2). Using the assumption of 100% availability throughout the year (all 365 possible cycles), the input/output analysis predicts a profitability of \$4,736,015.50/year (see Appendix A). Though this level of analysis does not include many important variables, it indicates that this process has the potential to become profitable.

Optimization

The design variable to be optimized in this procedure was the flow rate of the vanadium solution across the cell membrane. In order to find this optimized flow rate, a numerical approach was used. Utilizing the program MATLAB, this computational approach was carried out through a computer program. Prior to the completion of the economic potential calculation, optimization was performed due to the complexity of the optimization of flow rate. The entire basis of prior work (Moore 2012) was performed assuming that flow rate was so high that the state of charge did not drop across the membrane. This was a very unrealistic assumption because of the immense amount of friction generated within the stacks (Blanc 2010). Since friction increases by a factor of velocity squared (equation [2]), clearly the optimal flow rate could not occur at a rate where SOC drop is negligible.

$$h_{f,i} = f_i \frac{L_i}{D_i} \frac{V_{si}^2}{2g} \quad h_{mi} = k_{Li} \frac{V_{si}^2}{2g} \quad [2]$$

The development of a model and a computer program was required to efficiently complete the optimization. The MATLAB code (appendix E) was developed for that reasoning. The basis of the entire model used was the assumption that the flow of electrons across the membrane remains constant with time and flow rate. The accuracy of this model could likely be questioned because the membrane would likely not remain completely saturated under lower state of charges. However, due to the complexities of modeling the reaction and diffusion near the membrane no further investigation was made into the accuracy of the constant electron flow model. The electron flow was easily calculated since the area and current density were both known for the membrane. The electron flow rate was equal to the depletion of Vn^{2+} to Vn^{3+} , therefore a simple balance

of Vanadium concentrations around the cell was used to calculate the exit state of charge of a cell. Then using an equation derived from the Nernst Equation (equation [14]) voltage could be produced as a function of time.

$$V = E_0 + R * \frac{T}{zF} * \ln \frac{SOC^2}{(1-SOC)^2} \quad [14]$$

The program initially started with the minimum flow rate possible for developing electricity. This flow rate would be the flow rate that would produce a state of charge of 0 out of the cell when the entering state of charge would be 0.2. This assumption was made because the voltage produced by cell at any time is only a function of the lowest (exiting fluid) state of charge in the cell. Thus, if the flow rate was run any lower than this minimum flow rate, no electricity would be produced at the end of the cycle.

The program then found a tightly fitting equation to represent voltage as a function of time. The average value of this function overall all times was then saved in an output matrix. The flow rate was then increased by multiples of the minimum flow rate, from a range of 1.01*fmin to 50*fmin. The average voltage at each flow rate was added to output matrix. The power generated over the discharge cycle for each flow rate was then generated (equation [15]).

$$P = VI \quad [15]$$

The next step in order to optimize the VRFB flow rate is to take into consideration the significant head loss in the system. Essentially, the head loss can be placed into two categories: that from the piping system and that from the cell stacks. As the fluid-stack interface is much greater in area than that of the piping system, a vast majority of the head loss occurs in the cell stacks. To calculate the pipe head loss, the

MATLAB code begins a loop that determines whether the flow is turbulent or laminar, which then determines whether equation [3] or [4] is used as the friction factor. The loop then continues as it combines equations [1] and [2] to calculate the piping head loss from each given flow rate:

$$\Delta p_{pipe} = -\gamma \left(\frac{\Delta V_s^2}{2g} + \Delta Z + h_f + h_m \right) \quad [1]$$

$$h_{f,i} = f_i \frac{L_i}{D_i} \frac{V_{si}^2}{2g} \quad h_{mi} = k_{Li} \frac{V_{si}^2}{2g} \quad [2]$$

$$f_i = \frac{64}{Re_i} \quad [3]$$

$$\frac{1}{\sqrt{f_i}} = -2 \log \left(\frac{\varepsilon_i}{3.7D_i} + \frac{2.51}{Re_i \sqrt{f_i}} \right) \quad [4]$$

In this case, the flow rate in the code is varied from the minimum calculated value to 50 times the minimum value. Outside of this flow rate loop, the number of cells is also varied from 4000 to 10000, giving a large range of flow rates at various cell numbers.

Having such a unique, complicated structure, the head loss calculations incurred because of the stacks must be found empirically. In this case, finite element method (FEM) simulations may be run in order to generate a hydraulic resistance value, which, combined with equation [6] yield the pressure drop due to the stacks.

$$\Delta p_{stack} = QR^{\sim} \quad [6]$$

The addition of the head loss from the piping and the cell stacks then yields the total head loss for the system, which can be substituted into equation [8] to find the power required to pump the liquid across the total number of cells.

$$P_{pump} = \gamma h_p Q = \Delta p Q \quad [8]$$

In order for the optimal flow rate to be found, the maximum difference between the required power for pumping and the power generated by the cells must be calculated for

each flow rate. Once the code has accomplished this, it returns the highest difference value found in the array of differences. These matrices of power differences can then be used to develop plots against various values, such as number of cells or flow rate.

The output of the optimization program includes four figures and several design variables. Figure 4 (appendix C.3) is developed the by the calculations of the average voltage required to charge and discharge the cells over the various flow rates. Figure 4 demonstrates two main points. The first is that the cell efficiency being less than one causes the battery to require more power to charge the than it can discharge. Figure 4 also demonstrates that the average voltage of the cell increases very quickly as flow rate is increased. The average voltage quickly approaches an asymptote, thus after a large enough flow rate was reached any gains in power generation by increasing the flow rate would be negligible.

Figure 5 (appendix C.3) shows the voltage of the cell as a function of time at the optimal flow rate. This voltage curve was significant because it describes the operation of the battery. While the voltage for power generated was estimated to be the average of this curve (denoted *), the actual power generated for this curve at any given time would be the current produced multiplied by the number of cells multiplied by the voltage on the curve at any given time.

Figure 6 (appendix C.3) shows the net power generated as a function of flow rate. This graph demonstrates the main theory behind the optimization used. At some point, the power to generate a flow rate from pumps would become greater than the power gained by a faster flow rate. Thus the net power generation curve could be used to find the optimal flow rate for the system. This data point was found by simply finding the k

which develops the maxima clearly seen in figure three. This figure was also varied over a large variety of cell numbers to show how net power generation changed as a function of cells.

Figure 7 (appendix C.3) shows the result of generation of figure three under a variety of cell numbers. Figure 6 shows important data for further scale up and down of the system. It turns out that the maximum net power (net power under optimal flow rate) increases linearly with the number of cells in the system. An additional result of the development of figure 6 was that the optimal flow rate was independent of the number of cells in the system.

Finally, the program outputs several key design variables. The average voltage of the system under optimal flow rate (see figure 5) was developed as described above. The optimal flow rate (see figure 6) was also stated. The number of cells needed for the system to develop the desired power (12 MW) was developed by use of the data in figure 6. The actual power generated for that exact integer was an additional output. The number of cells in the stack was found by assuming the optimal voltage for the system to output was 120 Volts. Thus, 120 volts was divided by the average voltage and rounded to the nearest integer. Thus, 54 stacks of 75 cells were found to be optimal for the system.

In addition tank size was calculated (equation [23] and [24], appendix C.3) by the calculation of moles of vanadium required to provide all the cells operation from 0.8 SOC to 0.2 SOC for twelve hours.

$$M_v = (I_s * \tau_s * N_c * N_s) / (F * (SOC_i - SOC_f)) \quad [23]$$

$$V_t = \frac{M_v}{C_v} \quad [24]$$

The moles of vanadium calculated were used to develop the weight of vanadium or vanadium oxide required for the solution. Finally, the total surface was calculated by multiplying number of cells by the surface area of membrane in each cell. Finally, the pump power used was calculated specifically for the optimal flow rate by methods previously used to calculate power required for the pump. Upon successfully completing this optimization, a sound understanding of the effects of flow rate upon the VRFB system (most importantly, increasing the head loss, cell voltage, cell power, and pump power required) was attained. Using this newfound knowledge of the optimization in the VRFB system, a successful economic analysis on this same system could be conducted.

Power Capacity Analysis (EP3)

For EP3, we considered the costs that scale with the power capacity. This includes systems converting electricity from AC to DC, materials used to construct the cells and structures, costing for pumps needed to run the systems. Pump costing was found using methods described in Chemical Engineering Process Design and Economics (Ulrich 2004.) The number of stacks and cells were calculated from the optimization steps. Power lost was then calculated using equation [16]. This lost energy was all assumed to be lost to heat. Using equation [17], the heat generated from charge and discharge was approximately $9 * 10^5 \frac{J}{s}$ and $8.4 * 10^5 \frac{J}{s}$ respectively. However a temperature increase of only .02 degrees Celsius from equation [18], no heat exchanger or thermal system is needed to control temperature.

$$N_s = \frac{P}{V_s * I_s * \xi_c} \quad [16]$$

$$q = P * (1 - \xi_0) \quad [17]$$

$$\Delta T = \frac{q}{2 * C_p * F_a} \quad [18]$$

Using an interest rate of 10% and a lifespan of 10 or 20 years (stacks and pumps were assumed to have a life of 10 years, everything else 20), the fraction of the initial capital investment was found using equation [19] to be 0.0627 and 0.067.

$$f_{RI} = \frac{n \left[\frac{i(1+i)^n}{(1+i)^n - 1} \right] - 1}{n} \quad [19]$$

Using both equation [20] and [21], the annualized cost was found to be \$223,153.63 for the cell stack. EP3 was completed by using equation [22] and found to be \$2,853,088.28 for 100% runtime at 365 days/yr. All specific data can be found in Appendix C.4.

$$f_D = \frac{1}{n} \quad [20]$$

$$AC = C_{cost}(.14 + f_{RI} + f_D) \quad [21]$$

$$EP_3 = EP_2 - AC_s - AC_{HEX} - AC_p - AC_{PCS} \quad [22]$$

Energy Capacity Analysis (EP4)

For EP4, energy capacity was taken into consideration for costing. The number of moles of vanadium was found to be 6044000 by using equation [23], and volume of vanadium was found using a simple conversion shown in equation [24].

$$M_v = (I_s * \tau_s * N_c * N_s) / (F * (SOC_i - SOC_f)) \quad [23]$$

$$V_t = \frac{M_v}{C_v} \quad [24]$$

Using the price of \$14.33 (James 2010) for kg of Vanadium Oxide, the total cost of Vanadium was found to be approximately \$7.9 million. Sulfuric Acid cost about \$415,000 at \$.07 per kg (Sigma Aldrich.) Tank sizing was found to be 6044 m³ with a cost estimated around \$3.2 million (Ulrich 2004.) With a cost of \$8,330 per charge and a gain of \$21,000 per discharge, the net gain per cycle was around \$13,000. This stayed constant due to the fact that no more operating costs were added after EP3. Thus the slope of the economic potential lines remained constant after EP3. The specific data generated in EP4 can be found in appendix C.5. The results of EP4 can be found in tabular form in appendix D.1 and in figure 8 (appendix D.2).

Balance of Plant Analysis (EP5)

Included in the balance of plant costs are those associated with construction and land costs, control system costs, and building/site preparation costs. Using the number of stacks (and their square footage), tank square footage, an estimate of the plant space is generated (Table 14, appendix C.6). Predicting that the plant space is approximately 20% of the total space needed, a final square footage number is also generated (Table 14, appendix C.6). The rest of the costs are given based upon the calculated square footage (Tables 14 and 15, appendix C.6), or based upon the numbers seen in Mark Moore's report on VRFB (Moore 2012). The final cost of the balance of plant analysis is found with: $EP_5 = EP_4 - \text{Annualized Costs from } EP_5$ (Moore 2012). The specific data generated in EP5 can be found in appendix C.6. The results of EP5 can be found in appendix D.1 (tables) and D.2 (graph).

Capital Investment Analysis (EP6)

EP6 was a simple list of all capital costs calculated in EP3 through EP5. Table 17 (appendix C.7) estimates the total capital required to develop the optimized 12 MW Vanadium Redox Flow Battery. This capital was annualized in Economic Potentials 3 through 5 and thus already included in the overall analysis of the report. The annualization of the capital was performed based on a 10% interest rate and the assumption that pumps and stacks would have a life of ten years while all other aspects of the system would have a life of twenty years. However, the actual capital required for the proposed Vanadium Redox Battery exists in table 16.

Conclusions

Appendix D represents the conclusions of the economic analysis. After the inclusion of all capital costs, the 12 MW vanadium redox flow battery cannot be recommended for economic benefit currently. The massive capital costs associated with the project (table 16) are the major contributions to the annualized expense. Specifically the cost of Vanadium oxide causes the project to rapidly become unfeasible. The annualized expense of Vanadium is over \$2 million. Also, the PCS equipment for power conversion contributes to the massive capital costs with over \$6 million in capital. Thus, if the cost of these two capital expenses were lessened then the project would likely be feasible economically. Perhaps a used PCS system from a decommissioned power source could provide a cheaper alternative to the massive capital of a new system. However, the cost of vanadium shows no great alternatives. The only hope is that the cost of vanadium will continue to decrease with time. Vanadium still currently represents essentially the cheapest metal for use in a redox battery. However, \$14.33/ kg is far from feasible because of the over \$7 million in capital this price represents. As demand for vanadium increases across the world, additional mines could be constructed, increasing the availability and lowering the cost. Thus, only time could help make this project feasible due to the massive amounts of vanadium required for a 12 MW plant. In the current scenario, though, VRFBs may become a necessary component of the grid due to the implementation of green power sources. Thus, under the most ideal scenario with 100% cycle availability the battery will lose \$664,153.07 annually. In fact, even under the most ideal scenario, the price of the sold electricity would need to be raised approximately \$.03/kWh (from the value of \$.1576/kWh) simply to break even over the year.

Appendix A (Membrane efficiency)

Figure 2

Current Density vs Cell Voltage Data provided by Dr. Thomas Zawodzinski Group

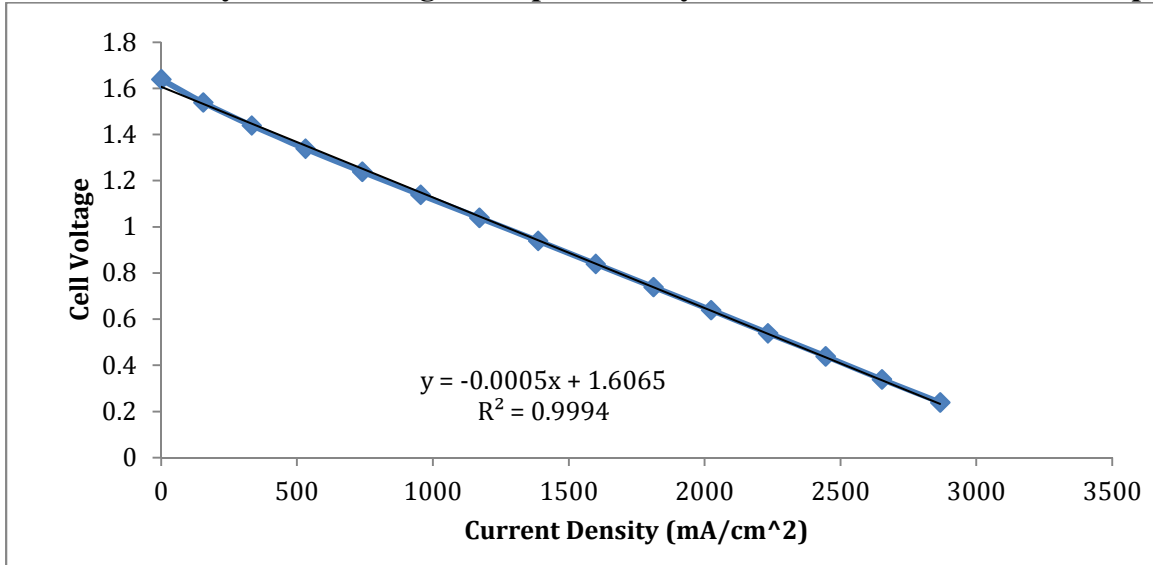

The cell efficiency was calculated using the data provided by Dr. Thomas Zawodzinski's Group at the University of Tennessee. The membrane used provides a current density of 200 mA/ cm². Thus, the cell efficiency was calculated to be the cell voltage at 200 mA/ cm² (1.5065 Volts by the fit equation above) divided by the open cell voltage (y-intercept= 1.6065.) Thus, the efficiency used for the economic analysis was roughly 0.9378.

Appendix B (equations)

Head loss calculations:

$$\Delta p_{pipe} = -\gamma \left(\frac{\Delta V_s^2}{2g} + \Delta Z + h_f + h_m \right) \quad [1]$$

$$h_{f,i} = f_i \frac{L_i}{D_i} \frac{V_{si}^2}{2g} \quad h_{mi} = k_{Li} \frac{V_{si}^2}{2g} \quad [2]$$

$$f_i = \frac{64}{Re_i} \quad [3]$$

$$\frac{1}{\sqrt{f_i}} = -2 \log \left(\frac{\epsilon_i}{3.7D_i} + \frac{2.51}{Re_i \sqrt{f_i}} \right) \quad [4]$$

$$Re = \frac{\rho V_s D}{\mu} \quad [5]$$

Stack Hydraulic Model Calculations:

$$\Delta p_{stack} = QR^{\sim} \quad [6]$$

Fun With Pumps:

$$\Delta p_{system} = \Delta p_{pipe} + \Delta p_{stack} \quad [7]$$

$$P_{pump} = \gamma h_p Q = \Delta p Q \quad [8]$$

Minimum Flowrate:

$$Q_{min\ deplete} = \frac{bN_{cell}i(t)}{F(c_{outmin} - c_{in})} \quad [9]$$

$$Q_{min\ augmented} = \frac{bN_{cell}i(t)}{F(c_{outmax} - c_{in})} \quad [10]$$

$$Q_{minimum}(t) = \max(Q_{min\ deplete}(t), Q_{min\ augmented}(t)) \quad [11]$$

Nernst Equation:

$$E_{red} = E_{red}^{\ominus} - \frac{RT}{zF} \ln \frac{a_{Red}}{a_{Ox}} \quad (\text{half - cell reduction potential}) \quad [12]$$

$$E_{cell} = E_{cell}^{\ominus} - \frac{RT}{zF} \ln Q \quad (\text{total cell potential}) \quad [13]$$

$$V = E_0 + R * \frac{T}{zF} * \ln \frac{SOC^2}{(1-SOC)^2} \quad [14]$$

General Electricity Power Equation:

$$P = VI \quad [15]$$

Power Capacity Considerations (EP3):

$$N_s = \frac{P}{V_s * I_s * \xi_c} \quad [16]$$

$$q = P * (1 - \xi_0) \quad [17]$$

$$\Delta T = \frac{q}{2 * C_p * F_a} \quad [18]$$

$$f_{RI} = \frac{n \left[\frac{i(1+i)^n}{(1+i)^n - 1} \right] - 1}{n} \quad [19]$$

$$f_D = \frac{1}{n} \quad [20]$$

$$AC = C_{cost} (.14 + f_{RI} + f_D) \quad [21]$$

$$EP_3 = EP_2 - AC_s - AC_{HEX} - AC_p - AC_{PCS} \quad [22]$$

Energy Capacity Analysis (EP4):

$$M_v = (I_s * \tau_s * N_c * N_s) / (F * (SOC_i - SOC_f)) \quad [23]$$

$$V_t = \frac{M_v}{C_v} \quad [24]$$

$$EP_4 = EP_3 - AC_V - AC_T - AC_{H2SO4} \quad [25]$$

Appendix C.1 (EP1)

Table 2

Table of Raw Materials and Costs

Vanadium Cost (2013 USGS)	\$14.33/kg
Ion-Exchange Membrane (Nafion Membrane) (James 2010)	\$20.73 per m ²
Current Collector Cost (Moore 2012)	\$51 per m ²
Carbon Felt Cost (Moore 2012)	\$20 per m ²

Table 3

Electricity cost variability based on Peak vs. Non-Peak Consumption

Price of Output Power (epb.net)	\$0.1576 per kWh
Price of Input Power (epb.net)	\$0.0541 per kWh

Table 4

Reaction Characteristics

Reaction Stoichiometry	$V^{3+} + e^{-} \leftrightarrow V^{2+}$ $VO^{2+} + H_2O \leftrightarrow VO_2^{+} + 2H^{+} + e^{-}$
Operating Temperature	25°C
Concentration of Vanadium	1 M
Concentration of H ₂ SO ₄	5 M
Power Capacity	12,000 kW
Energy Capacity	144,000 kWh
SOC Considerations/Limits	$0.20 \leq SOC \leq 0.80$
Solution Density	1285 g/L

Table 5

Design Details

Cycles per Year	Varying from 1-365 cycles
Size of Cell	1 m ²
Design Current Density	40 mA/cm ²
Materials of Construction for Tanks and Heat Exchangers	Tanks: PVC Heat Exchangers: High Ni Steel

Appendix C.2 (EP2)

Figure 3

Net profit versus cycles per year

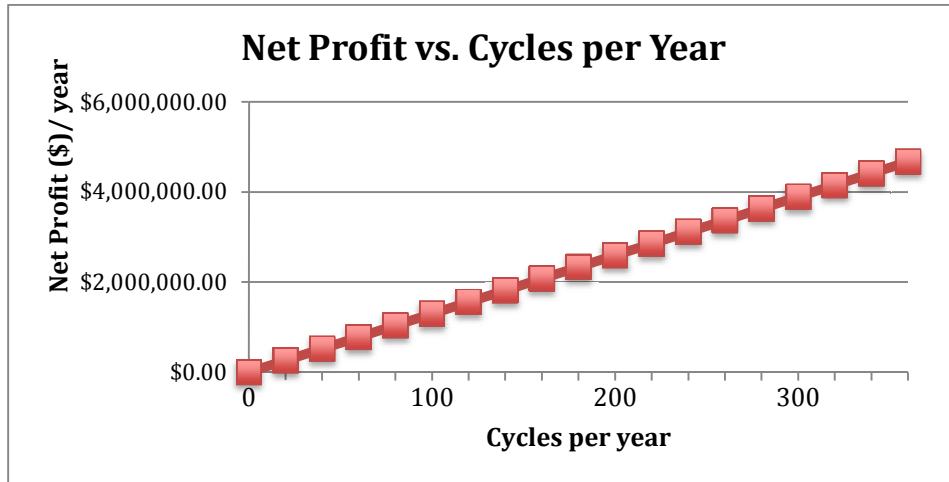

Appendix C.3 (Optimization)

Figure 4

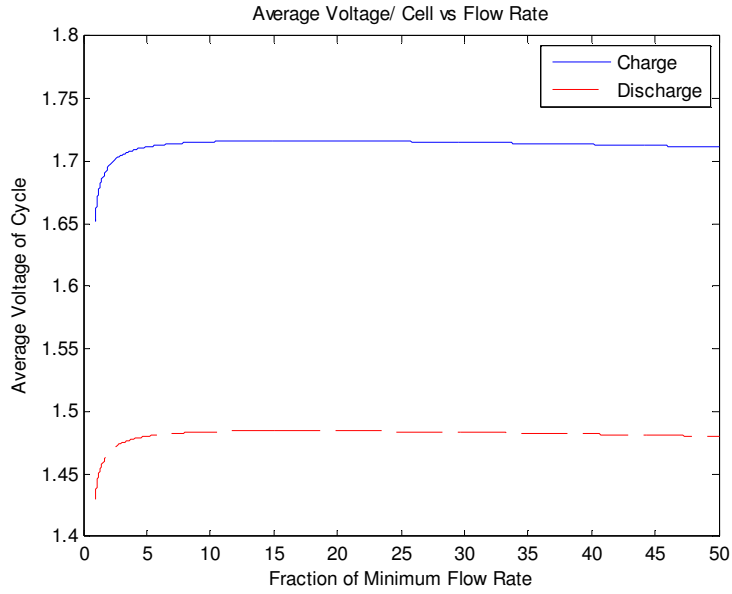

Figure 5

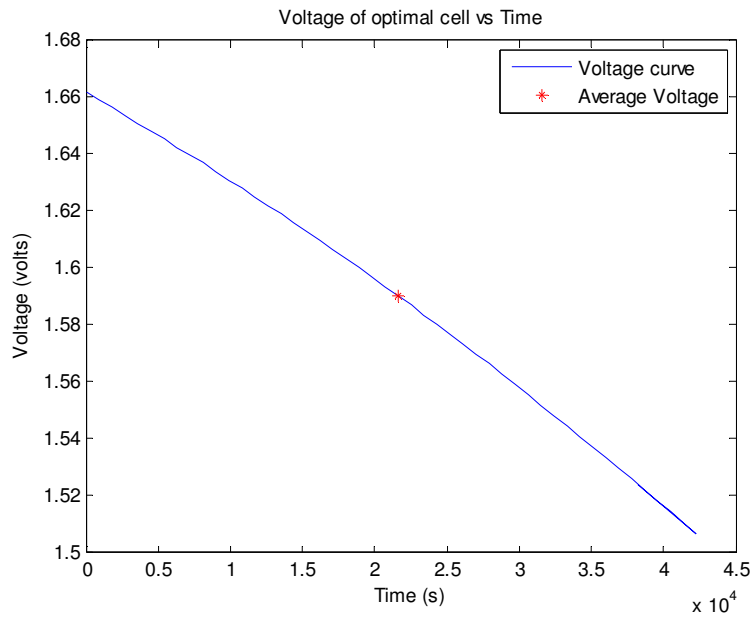

Figure 6

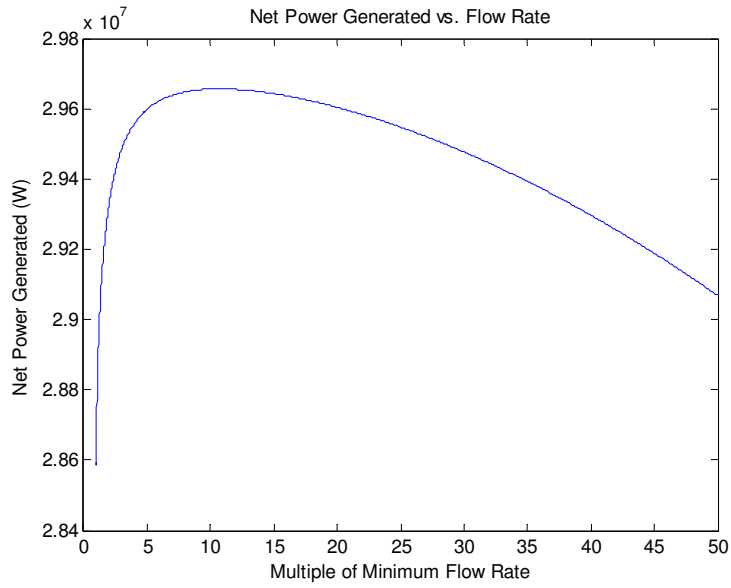
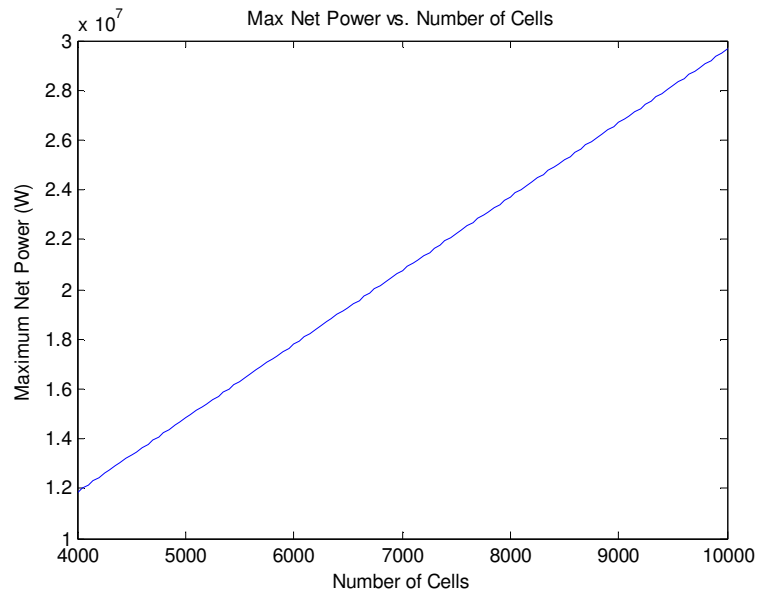

Figure 7



Appendix C.4 (EP3)

Table 6: Heat Calculations for EP3

Number of Cells	4050	
Flow Rate	1.1142	L/s cell
Flow Rate	4.51251	m ³ /s
Density of Water	1000000	g/m ³
Mass Flow Rate	4512510	g/s
Membrane Efficiency	0.93	
Heat Capacity	4.2	J/g*k
Power Generated	12000000	W
Heat from Charge	903225.81	J/s
Heat from Discharge	840000	J/s
Delta T Charge	0.02	C
Delta T Discharge	0.02	C

Table 6: Pump Costing for EP3

Pump Size	12358	W
Pump Size (hp)	16.57	hp
Pump Cost/Pump	17500	
Pump Efficiency	0.75	
Electricity/Charge (Discharge already accounted for)	197.728	kwh
Annualized Electricity Cost/Pump	10.16519648	
Number of Pumps	2	
Capital of Pumps	\$35,000.00	
Annualized running cost/cycle	\$20.33	

Table 7: PCS equipment costing for EP3

PCS Equipment Costs	265	\$/kw
Discharge Power	11160	kw
Charge Power	12903.23	kw
PCS Charge (AC-> DC)	\$2,957,400.00	
PCS Discharge (DC -> AC)	\$3,419,354.84	

Table 8: Cell Costing for EP3

Cell Costs		
Membrane Area	8100	m ²
Nafeon Membrane	20	\$/m ²
Current Collectors	51	\$/m ²
Carbon Felt Cost	20	\$/m ²
Stack Cost	\$737,100.00	

Table 9: EP3 Continued

Annualization	
Interest Rate	0.1
fR1 for 10 years	0.062745395
fR1 for 20 years	0.067459625
Depreciation for 10 Years	0.10
Depreciation for 20 Years	0.05
A(10)	0.30
A(20)	0.26

Annualized Costs for EP3	
Pumps	\$10,596.09
Cell Stack	\$223,153.63
PCS System	\$1,641,756.91

Cost/Charge	\$8,329.39
Cost/Discharge	\$21,284.44
Net Cost/ cycle	\$12,955.05

Appendix C.5 (EP4)

Table 10: Vanadium Calculations

Vanadium Needed	6044000	mols
Vanadium Oxide Needed	549680	kg
Cost of Vanadium Oxide	14.33	\$/kg
Total Cost of Vanadium	\$7,876,914.40	

Table 11: Sulfuric Acid Calculations

Sulfuric Acid Needed	5928347.52	kg
Cost of Sulfuric Acid	0.07	\$/kg
Total Cost of H ₂ SO ₄	\$414,984.33	

Table 12: Tank Sizing

Tanks Needed	2	
Tank Size	6044.4	m ³
Cost of Tank	\$1,600,000.00	
Cost of Tanks	\$3,200,000.00	

Table 13: Annualization and EP4

A(20)	0.26
Vanadium	\$2,027,987.43
Sulfuric Acid	\$106,841.71
Tanks	\$823,870.80

EP4	
Cost/Charge	\$8,329.39
Cost/Discharge	\$21,284.44
Net cost/Cycle	\$12,955.05

Appendix C.6 (EP5)

EP5

Table 14: Plant Prep Costs

Size of Stacks	1.2	m ²
Stacks	54	
Tank Size Estimate (Area)	226.1946711	m ²
Stack Size Estimate	64.8	m ²
Space of Plant	290.9946711	m ²
Plant Accounting for ~20% of Total Area	1454.973355	m ²
Building and Prep Costs	1012	\$/m ²
Cost	\$1,472,433.04	

Control System Estimate	\$25,000.00
-------------------------	-------------

Table 15: Costs and Annualizing for EP5

Remaining Costs	12000	kw
Cost	56	\$/kw
Total Remaining Cost	\$672,000.00	

Annualizing Cost	
AC(20)	0.26
Building and Prep	\$379,092.06
Control System	\$6,436.49
Remaining	\$173,012.87

Appendix C.7 (EP6)

Table 16: Capital Cost Table for EP6

Equipment Identification	Number	Capacity/Size	Price (Year)	Price (Target Year)	Base Bare Module Factor	Base Bare Module Cost	Material Factor	Pressure or Other Factors	Actual Bare Module Factor	Actual Bare Module Cost
Cell Stacks	4050	8100 m ²	\$91/m ² (2012)	\$91/m ² (2012)	1	\$737,100.00	1	1	1	\$737,100.00
Vanadium Oxide	-	614830 kg	\$14.33/kg (2011)	\$14.45/kg (2012)	1	\$8,884,293.00	1	1	1	\$8,884,293.00
Sulfuric Acid Solution	-	5928348 kg	\$0.07/kg (2012)	\$0.07/kg (2012)	1	\$414,984.33	1	1	1	\$414,984.33
Tanks (PVC)	2	6044 m ³	\$1,600,000 (2004)	\$2,340,000 (2012)	1	\$4,680,000.00	1	1	1	\$4,680,000.00
Pumps (Stainless Steel, Centrifugal)	2	16.57 hp	\$17,500 (2004)	\$25,594 (2012)	8	\$409,504.00	1.9	2	8	\$409,504.00
PCS	-	1200 kW	\$264/kW (2012)	\$264/kW (2012)	1	\$6,376,754.84	1	1	1	\$6,376,754.84
									Total	\$21,502,636.17

Appendix D.1 (Economic Potential Tables)

Table 17: Economic Potentials based on number of cycles run annually

cycles	EP2	EP3	EP4	EP5
0	\$0.00	\$1,875,506.63	\$4,834,206.56	\$5,392,747.98
20	\$259,507.70	\$1,616,405.54	\$4,575,105.47	\$5,133,646.89
40	\$519,015.40	\$1,357,304.45	\$4,316,004.38	\$4,874,545.80
60	\$778,523.10	\$1,098,203.36	\$4,056,903.29	\$4,615,444.70
80	\$1,038,030.79	-\$839,102.26	\$3,797,802.20	\$4,356,343.61
100	\$1,297,538.49	-\$580,001.17	\$3,538,701.11	\$4,097,242.52
120	\$1,557,046.19	-\$320,900.08	\$3,279,600.02	\$3,838,141.43
140	\$1,816,553.89	-\$61,798.99	\$3,020,498.93	\$3,579,040.34
160	\$2,076,061.59	\$197,302.10	\$2,761,397.84	\$3,319,939.25
180	\$2,335,569.29	\$456,403.19	\$2,502,296.74	\$3,060,838.16
200	\$2,595,076.99	\$715,504.28	\$2,243,195.65	\$2,801,737.07
220	\$2,854,584.68	\$974,605.37	\$1,984,094.56	\$2,542,635.98
240	\$3,114,092.38	\$1,233,706.46	\$1,724,993.47	\$2,283,534.89
260	\$3,373,600.08	\$1,492,807.55	\$1,465,892.38	\$2,024,433.80
280	\$3,633,107.78	\$1,751,908.64	\$1,206,791.29	\$1,765,332.71
300	\$3,892,615.48	\$2,011,009.73	-\$947,690.20	\$1,506,231.62
320	\$4,152,123.18	\$2,270,110.82	-\$688,589.11	\$1,247,130.52
340	\$4,411,630.88	\$2,529,211.92	-\$429,488.02	-\$988,029.43
360	\$4,671,138.57	\$2,788,313.01	-\$170,386.93	-\$728,928.34
365	\$4,736,015.50	\$2,853,088.28	-\$105,611.66	-\$664,153.07

Appendix D.2 (Economic Potential Graph)

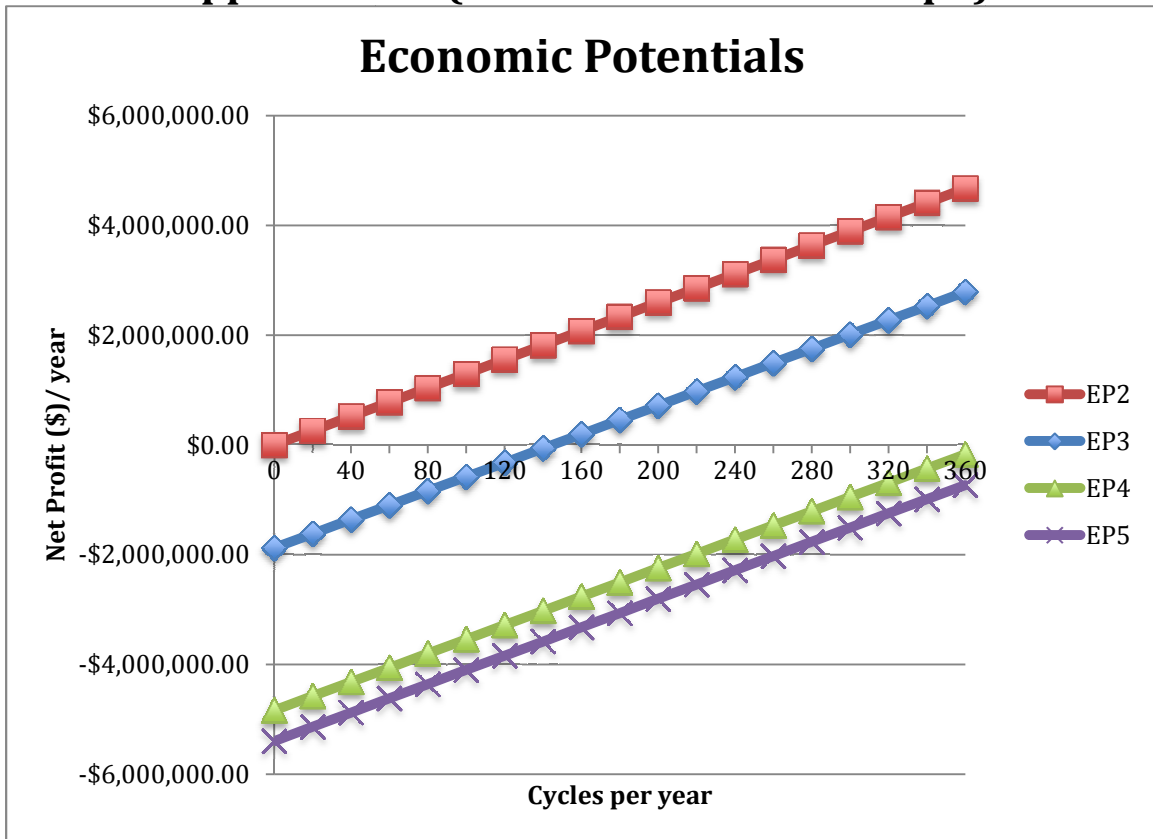

Appendix E (Matlab Optimization Code)

```
clc
clear all
close all

% The following code was written for the optimization of a vanadium redox
% flow battery. Specifically the flow rate through the battery was
% optimized by finding the maximum point of net power generated by the
% battery during discharge taking into account the cost of power for
% pumping the solution through the membrane. This code was generated by
% Kevin Spellman, Kendrick Stiles, and Ian Little for the purpose of Senior
% Design project for CBE 488 and subsequent Honor's Thesis. The code may
% not be reused by others without premission of the authors and proper
% recognition. All data generated by the code is also property of the
% authors and proper recognition is necessary for its use.
soc0=0.8;
socf=0.2;
concV = 1; %Conc of Vanadium
Vn20=soc0.*concV; %Vn2+ + Vn3+ = 1 molar always by definition
Vn2f=socf.*concV;
cd=.2; %A/cm^2
Area=10000; %cm^2
current=Area.*cd; %amps= coulombs/ s
F= 96485.3365; %Coulombs/ mol
eflow=current./F; %mol/s
t=0:15*60:12*3600; %min measuring every 15 minutes
flowmin=eflow/0.2; %lowest possible SOCin=0.2/ SOCout=0
%derived from mass balance
flowminm3 = flowmin*.001; %min flow in m^3/s
vavg=[];
k =[];
psi = [];

for kk=1:5000 %percentage of minimum flow rate used in trial
    k(kk)=kk*.01;
    if k(kk)<1;
        k(kk)=1;
    end
    psi(kk)=k(kk).*flowmin; %psi= flowrate (L/s)
    ilast=length(t);
    tspc=t(ilast).*eflow./(Vn20-Vn2f);
    t(ilast)=t(ilast)-1;
    Vn2out=[];
    Vn2in=[];
    SOC=[];

    for i=1:ilast
        Vn2in(i)= (Vn20.*tspc-eflow.*t(i))./tspc;
        Vn2out(i)=(Vn2in(i).*psi(kk)-eflow)./(psi(kk));
        SOC(i)=Vn2out(i)./1 ; %1 molar solution
    end
    E0=1.602; %open circuit voltage= 1.602
    R=8.314; %J/mol K
    Temp=298; %Assume STP
    V=E0+R.*Temp./F.*log(SOC.^2./(1-SOC).^2);

    % plot(t,V);
    % hold
    p=polyfit(t,V,2);
    f=polyval(p,t);
```

```

% plot(t,f);
vavg(kk)=mean(f);
end
n=0.93;
Vdischarge=vavg.*n;
Vcharge=vavg./n;

gpm = psi*15.85; %Conversion of flow into gpm (1 L/s = 15.85 gpm)
m3 = psi*.001; %Conversion of flow into m^3/s (1 L/s = .001 m^3/s)

% figure(1)
% plot(k,Vcharge)
% hold on
% plot(k,Vdischarge,'--r')
% title('Average Voltage/ Cell vs Flow Rate')
% xlabel('Fraction of Minimum Flow Rate')
% ylabel('Average Voltage of Cycle')
% legend('Charge','Discharge')

pcharge=Vcharge.*current;
pdischarged=Vdischarge.*current;

% figure(2)
% plot(k,pcharge)
% hold on
% plot(k,pdischarged,'--r')
% title('Power generated/ Cell vs Flow rate')
% xlabel('Fraction of Minimum Flow Rate')
% ylabel('Power per cell (W)')
% legend('Power to charge', 'Power to discharge')

Powergen=12*10^6; %W
Ncells= Powergen./pdischarged;

% figure(3)
% plot(k,Ncells);
% title('Number of cells vs flow rate')
% xlabel('Fraction of Minimum Flow Rate')
% ylabel('Number of cells')

%% Head loss/Velocity calcs

htotal = []; %Total head loss
di = .1; %Diameter (m)
A1 = pi*(di/2)^2; %Pipe area (m^2)
vel = [];
llength = 1; %Pipe length (m)
gamma = -1; %DeltaP equation constant
gravity = 9.81; %Acceleration due to gravity (m^2/s)
density = 997; %Density of solution at STP (kg/m^3)
viscosity = 0.9; %Viscosity of solution at STP (
elbow = 2; %Number of 90 degree elbows
kelbow = 1.5; %Constant for head loss due to elbows
dZ = 10; %Change in height (m)
Ratio = 14186843/19; %Stack flow resistance (Pa/m^3)/# of cells
Ppump = [];

```

```

Pdiff = [];
peff=0.75 %assuming 75% pump efficiency

vel = m3/A1; %Calculates fluid velocities depending on pipe size
powermaxes = []; %Matrix that will be filled with max net power outputs
newcells = [4000:50:10000]; %Matrix of cell numbers to use
flowmaxes = []; %Matrix with maximum flow rates from each cell number
kopts = [];
pwrmx = [];

for dd = 1:numel(newcells)

for ii = 1:kk %Calculates head losses for each velocity

Re = density*di*vel(ii)/viscosity; %Reynolds #

if Re < 2100 %Calc for friction factor based on Re
fi=65./Re;
else
fi0=65./Re;
eata=1; %go back to find out roughness
fi=fi0;
limit=.001./100;
i3=1;
i5=1;
fi2=[];
fi2(i5)=fi0;
while i3>limit
i5=i5+1;
fi2(i5)=(1./(-2.*log(eata./(3.7.*di)+2.51./(Re.*sqrt(fi2(i5-1))))))^2;
i3=abs(fi2(i5)-fi2(i5-1))./fi2(i5);
fi=fi2(i5);
end
end

hfi = fi*llength/di*vel(ii)^2/(2*gravity); %Head loss from length
hml = elbow*kelbow*vel(ii)^2/(2*gravity); %Head loss from elbows
htotal = hml+hfi;

dPpipe = -1*gamma*(vel(ii)^2/(2*gravity)+dZ+htotal); %Calc dP for pipe
R = Ratio*newcells(dd); %Calc resistance of flow with actual number of
%cells
dPstack = m3(ii)*R; %Calc dP for stack
dPtotal = dPpipe + dPstack; %Total dP
Ppump(ii) = dPtotal*m3(ii)./peff; %Power used by pump
Pdiff(ii) = pdischarged(ii)*newcells(dd) - 2.*Ppump(ii); %Power
%difference between pumping power and power discharged

end

figure(4)
plot(k,Pdiff)
title('Net Power Generated vs. Flow Rate')
xlabel('Multiple of Minimum Flow Rate')
ylabel('Net Power Generated (W)')

```

```

for ii = 2:kk

    if Pdiff(ii) > Pdiff(ii-1)

        flowmax = m3(ii); %Flow rate at which power diff is maximum
        Pmax = Pdiff(ii); %Maximum power difference
        i7=ii;
    end
end

flowmaxes(dd) = flowmax;
kopts(dd) = flowmax./flowminm3;
powermaxes(dd) = max(Pdiff);
pwrmx(dd) = Pmax;

end

figure(5)
plot(newcells,powermaxes)
xlabel('Number of Cells')
ylabel('Maximum Net Power (W)')
title('Max Net Power vs. Number of Cells')

kopt=kopts(1);

% Redeveloping figures 1-3 used earlier now for optimal flow rate

psi2=kopt.*flowmin; %psi= flowrate (L/s)
ilast=length(t);
tspc=t(ilast).*eflow./(Vn20-Vn2f);
t(ilast)=t(ilast)-1;
Vn2outopt=[];
Vn2inopt=[];
SOCopt=[];

for i=1:ilast
    Vn2inopt(i)= (Vn20.*tspc-eflow.*t(i))./tspc;
    Vn2outopt(i)=(Vn2inopt(i).*psi2-eflow)./(psi2);
    SOCopt(i)=Vn2outopt(i)./1 ; %1 molar solution
end
E0=1.602; %open circuit voltage= 1.602
R=8.314; %J/mol K
Temp=298; %Assume STP
V=E0+R.*Temp./F.*log(SOCopt.^2./(1-SOCopt).^2);

% plot(t,V);
% hold
p=polyfit(t,V,2);
f=polyval(p,t);
figure(2)
plot(t,f);
title('Voltage of optimal cell vs Time')
xlabel('Time (s)')
ylabel('Voltage (volts)')
vavgopt=mean(f);
hold on
tavg=0;
for i7=1:length(t)

```

```

if V(i7)> vavgopt
    tavg=t(i7);
    i8=i7;
end
end
plot(tavg,V(i8),'*r')
legend('Voltage curve','Average Voltage')

n=0.93;
Vdischargeopt=vavgopt.*n;
Vchargeopt=vavgopt./n;

figure(1)
plot(k,Vcharge)
hold on
plot(k,Vdischarge,'--r')
title('Average Voltage/ Cell vs Flow Rate')
xlabel('Fraction of Minimum Flow Rate')
ylabel('Average Voltage of Cycle')
legend('Charge','Discharge')

vavgopt
kopt
psi2
cellnum=0;
for i9=1:numel(newcells)
    if powermaxes(i9) <1.2*10^7
        cellnum=i9;
    end
end
cellsneeded=newcells(cellnum+1)
Powergenerated=powermaxes(cellnum+1)
cellsinstack=floor(120./vavgopt)
stacks=cellsneeded./cellsinstack

% Calculating vanadium needed
Vmols=eflow.*12.*3600./0.6.*cellsneeded;%(mols)
%1/1 electron rate vs VN depletion and only 60% of vanadium is used in
% depletion cycle
Tanksize=Vmols./concV % Liters
VnMW=50.9415; % g/mol %molecular mass of vanadium
kgV=Vmols.*2.*VnMW./1000 %kg of Vneeded
kgVn2O5=Vmols./2.*181.88./1000 %kg of Vn2O5 needed for solution

% Calculating Nafion membrane size
Totalsurface=Area./100^2.*2.*cellsneeded %m^2
%membrane area * cells * 2 membrances/ cell

% Sizing pump
ii=round(kopt./0.01);

Re = density*di*vel(ii)/viscosity; %Reynolds #

if Re < 2100 %Calc for friction factor based on Re
    fi=65./Re;
else
    fi0=65./Re;
    eata=1; %go back to find out roughness

```

```

fi=fi0;
limit=.001./100;
i3=1;
i5=1;
fi2=[];
fi2(i5)=fi0;
while i3>limit
    i5=i5+1;
fi2(i5)=(1./(-2.*log(eata./(3.7.*di)+2.51./(Re.*sqrt(fi2(i5-1))))))^2;
    i3=abs(fi2(i5)-fi2(i5-1))./fi2(i5);
    fi=fi2(i5);
end
end

hfi = fi*llength/di*vel(ii)^2/(2*gravity); %Head loss from length
hml = elbow*kelbow*vel(ii)^2/(2*gravity); %Head loss from elbows
htotal = hml+hfi;

dPpipe = -1*gamma*(vel(ii)^2/(2*gravity)+dZ+htotal); %Calc dP for pipe
R = Ratio*newcells(dd); %Calc resistance of flow with actual number of
%cells
dPstack = m3(ii)*R; %Calc dP for stack
dPtotal = dPpipe + dPstack; %Total dP
Pumppower = dPtotal*m3(ii)./peff%Watts %Power used by pump

```

References

- Christian Blanc and Alfred Rufer (2010). Understanding the Vanadium Redox Flow Batteries, Paths to Sustainable Energy, Dr Artie Ng (Ed.), ISBN: 978-953-307-401-6, InTech, Available from: <http://www.intechopen.com/books/paths-to-sustainable-energy/understanding-the-vanadium-redox-flow-batteries>
- Eckroad, S., “Vanadium Redox Flow Batteries: An In-Depth Analysis”. Palo Alto: EPRI, 2007.
- EPRI-DOE Handbook of Energy Storage for Transmission & Distribution Applications, EPRI, Palo Alto, CA, and the U.S. Department of Energy, Washington, DC: 2003. 1001834.
- James, Kalinoski, Baum. “Mass Production Cost Estimation for the Direct H₂ PEM Fuel Cell System for Automotive Applications: 2010 Update”. Directed Technologies, Inc., Arlington, Va. (Prepared under subcontract AGB-0-40628-01 to U.S. Department of Energy) (September 30, 2010).
- Moore, Mark, Counce, Robert, et al. “A Step by Step Methodology for a Base Case Vanadium Redox-Flow Battery”. University of Tennessee, Knoxville. 2012. Print.

Mouron, Elizabeth Hope, "The Economic Potential of the All-Vanadium Redox Flow Battery With a Focus on State of Charge" (2011). University of Tennessee Honors Thesis Projects.

http://trace.tennessee.edu/utk_chanhonoproj/1421

Ulrich, Gail, Vasudevan, P. T. Chemical Engineering Process Design and Economics. A Practical Guide. Second Edition. Durham , New Hampshire: Process Publishing, 2004.

Watt-Smith, M.J., Ridley, P., Wills, R.G.A., Shah, A.A. and Walsh, F.C. (2013), The importance of key operational variables and electrolyte monitoring to the performance of an all vanadium redox flow battery. *J. Chem. Technol. Biotechnol.*, 88: 126–138. doi: 10.1002/jctb.3870