

A Base Case Design and Capital Cost Analysis of an All Vanadium Redox-Flow Battery

A Thesis Presented for
the Master of Science
Degree
The University of Tennessee, Knoxville

Mark Alan Moore
August 2013

Copyright© 2013 by Mark Moore
All rights reserved.

ABSTRACT

Interest in the development of redox-flow batteries (RFBs) for large-scale grid storage is growing, and considerable investments have been made into the research and development of RFBs over the past few decades. Unfortunately, practical implementation has been hampered by various cost and performance issues typical of an immature state of development. One critical factor for the competitiveness of this technology is the installed cost. The purpose of this work is to develop an evolutionary procedure to be used for the base-case design of a Vanadium Redox-Flow Battery, and to incorporate recent developments in all-vanadium RFB research in order to present an analysis of the associated cost factors. The design methodology is based on the work of Douglas (1985) and provides a profitability analysis at each decision level so that more profitable alternatives and directions can be identified before additional time and effort is expended on an impractical design. The major components of a RFB that affect installed cost are also identified and used as variables to create a capital cost function. The function is then used to calculate the rate of change of the capital costs with respect to the major components. The capital costs are also calculated for a range of component values and presented. Key findings include a high sensitivity of system capital cost to purity of vanadium and substantial fractions of the cost associated with perfluorosulfonic acid membranes currently used for proton transport. The key factors that contribute to the capital cost trends of different VRB designs are also examined, leading to a simple method for selecting key design variables before beginning the design process itself.

Table of Contents

CHAPTER 1: INTRODUCTION.....	1
INTRODUCTION	2
<i>Background</i>	2
<i>Objective</i>	2
CHAPTER 2: BASE CASE DESIGN AND CAPITAL COST ESTIMATE OF A VANADIUM REDOX-FLOW BATTERY.....	3
ABSTRACT	4
INTRODUCTION	4
BACKGROUND.....	6
PROCESS SYNTHESIS HIERARCHY	9
<i>Level 1: Input Information for the VRB</i>	9
<i>Level 2: Input-Output Analysis</i>	11
<i>Level 3: Power Capacity Considerations</i>	12
<i>Level 4: Energy Capacity Considerations</i>	17
<i>Level 5: Balance of Plant</i>	20
<i>Level 6: Capital Investment Estimate</i>	20
FUTURE POSSIBLE COST REDUCTIONS	21
GENERAL OBSERVATIONS.....	22
CONCLUSIONS.....	24
WORKS CITED.....	27
CHAPTER 3: CAPITAL COST SENSITIVITY ANALYSIS OF AN ALL-VANADIUM REDOX-FLOW BATTERY.....	28
ABSTRACT	29
INTRODUCTION	29
BACKGROUND.....	30
METHOD	33
RESULTS	40
CONCLUSION.....	43
WORKS CITED.....	47
CHAPTER 4: AN ANALYSIS OF THE CONTRIBUTIONS OF CURRENT DENSITY AND VOLTAGE EFFICIENCY TO THE CAPITAL COSTS OF AN ALL VANADIUM REDOX-FLOW BATTERY	48
INTRODUCTION	49
METHODOLOGY	53
RESULTS	56
CONCLUSION.....	58
CHAPTER 5: CONCLUSIONS	64
CONCLUSIONS.....	65
VITA	66

List of Tables

TABLE 2-1. REACTION RELATED INFORMATION.....	10
TABLE 2-2. DESIGN DETAILS.....	10
TABLE 2-3. COST INFORMATION.	11
TABLE 2-4. ANNUAL EXPENSES PROPORTIONAL TO FIXED CAPITAL.....	17
TABLE 2-5. LEVEL 3 CAPITAL COSTS.	19
TABLE 2-6. LEVEL 4 CAPITAL COSTS.	21
TABLE 2-7. CAPITAL COST ESTIMATE.	22
TABLE 2-8. CAPITAL COST ESTIMATES AT REDUCED ION EXCHANGE MEMBRANE COST.	23
TABLE 3-1. NOMENCLATURE.....	36
TABLE 3-2. SUMMARY OF RELATIVE SENSITIVITY INDEXES.....	37
TABLE 4-1. PARAMETERS FOR FIXED CAPITAL INVESTMENT ESTIMATES.....	53
TABLE 4-2 DESIGN VARIABLES FOR ESTIMATE OF VRB FIXED CAPITAL INVESTMENT.....	59

List of Figures

FIGURE 2-1. SCHEMATIC REPRESENTATION OF A VANADIUM REDOX-FLOW BATTERY.	7
FIGURE 2-2. THE CELL VOLTAGE AT DIFFERENT SOCs FOR (A) A CURRENT DENSITY OF 40 MA/CM ² AND (B) AND CURRENT DENSITY OF 80 MA/CM ²	12
FIGURE 2-3. ECONOMIC POTENTIAL FOR A VANADIUM REDOX-FLOW BATTERY.	13
FIGURE 2-4. CELL STACK CONSTRUCTION.	14
FIGURE 2-5. ECONOMIC POTENTIAL FOR A VANA REDOX-FLOW BATTERY AT REDUCED MEMBRANE COST CONDITIONS.	24
FIGURE 2-6. ECONOMIC POTENTIAL FOR A VANADIUM REDOX-FLOW BATTERY AT REDUCED MEMBRANE COST CONDITIONS AND REDUCED VANADIUM COST.....	25
FIGURE 3-1. SCHEMATIC REPRESENTATION OF A VANADIUM REDOX –FLOW BATTERY.....	31
FIGURE 3-2. THE EFFECT OF SOC ON CELL ELECTRICAL POTENTIAL.....	34
FIGURE 3-3. THE CAPITAL COSTS OF THE BASE CASE VRB.	35
FIGURE 3-4. THE CELL VOLTAGE AT DIFFERENT SOC FOR (A) A CURRENT DENSITY OF 40 MA/CM ² AND (B) A CURRENT DENSITY OF 80 MA/CM ²	38
FIGURE 3-5. THE EFFECT OF MEMBRANE COST ON CAPITAL COSTS.	41
FIGURE 3-6. THE EFFECT OF CURRENT DENSITY ON CAPITAL COSTS.	42
FIGURE 3-7. THE EFFECT OF CURRENT DENSITY ON CAPITAL COSTS FOR DIFFERENT ELECTRODE COSTS.....	43
FIGURE 3-8. THE EFFECT OF CYCLE TIME ON CAPITAL COST PER KILOWATT-HOUR FOR A 1 MW VRB.	44
FIGURE 3-9. THE EFFECT OF VANADIUM ELECTROLYTE COST ON A VRB	45
FIGURE 3-10. THE EFFECT OF SOC LIMITS ON CAPITAL COSTS PER KILOWATT-HOUR.....	46
FIGURE 3-11. THE EFFECT OF CYCLE TIME AND POWER CAPACITY ON CAPITAL COSTS PER KILOWATT-HOUR FOR A 12 MWH VRB.....	46
FIGURE 4-1. SCHEMATIC OF A VANADIUM REDOX-FLOW BATTERY.[1]	50
FIGURE 4-2. CELL POTENTIAL VS CURRENT DENSITY FOR A LABORATORY VRB (ION EXCHANGE MEMBRANE = NAFION N 211; TEMPERATURE = 30 C; AND V AND H ₂ SO ₄ CONCENTRATION ARE 1.7 AND 3.3 MOL/L.	57
FIGURE 4-3. FIXED CAPITAL INVESTMENT PER KWH VS CURRENT DENSITY	58
FIGURE 4-4. PURCHASE COST OF STACKS PER KW/HR VS CURRENT DENSITY	59
FIGURE 4-5. 1/(CD* ϵ_v) VS CURRENT DENSITY	60
FIGURE 4-6. TOTAL MEMBRANE AREA VS CURRENT DENSITY	60
FIGURE 4-7. PURCHASE COST OF VANADIUM PER KWH VS CURRENT DENSITY	61

FIGURE 4-8. MOLES OF VANADIUM REQUIRED VS CURRENT DENSITY	61
FIGURE 4-9. $1/(\xi^*V)$ VS CURRENT DENSITY	62

Nomenclature

Term	Description	Units
A	Surface area of heat exchanger	m ²
A _C	Electrode area	m ²
A _{Cell}	Electrode area of one cell	m ²
AC _{BP}	Annualized cost of balance of plant costs	\$/yr
AC _{HEX}	Annualized cost of heat exchangers	\$/yr
AC _p	Annualized cost of pumps	\$/yr
AC _{PCS}	Annualized cost of power conditioning system	\$/yr
AC _S	Annualized cost of stacks	\$/yr
AC _T	Annualized cost of storage tanks	\$/yr
AC _V	Annualized cost of vanadium	\$/yr
A _{total}	Total Area of Membrane or Electrodes	m ²
C _{cost}	Capital cost of a component	\$
CD	Current Density	mA/cm ²
C _p	Heat capacity of vanadium ion solution	J/(°C l)
C _{V2}	Concentration of V (II) ions	mol/l
C _{V3+}	Concentration of V (III) ions	mol/l
C _{V4+}	Concentration of V (IV) ions	mol/l
C _{V5+}	Concentration of V (V) ions	mol/l
ε _i	Intrinsic efficiency of pump	
ξ _C	Charging efficiency	
ξ _D	Discharging efficiency	
ξ _V	Voltage efficiency for charging or discharging	
E _C	Energy used to charge the battery	kW-hr
E _D	Energy discharged from the battery	kW-hr
E ₀	Open circuit voltage	Volts
E _{SC}	Energy capacity of the battery	kW-hr
EP ₂	Economic potential for Level 2	\$/yr
EP ₃	Economic potential for Level 3	\$/yr
EP ₄	Economic potential for Level 4	\$/yr
EP ₅	Economic potential for Level 5	\$/yr
f _D	Depreciation factor	
f _{RI}	Return on investment factor	
F	Faraday's constant	C/mol
F _A	Actual flow rate of vanadium ion solution	l/s
FCI	Fixed Capital Costs	\$
F _M	Minimum flow rate of vanadium ion solution	l/s
I _D	Current density of electrodes	amp/m ²
I _S	Current through a stack	amp
M _L	Concentration of V (II) at lower charging limit of 0.20	mol/l
M _T	Total concentration of vanadium	mol/l

M_U	Concentration of V (V) at upper charging limit of 0.80	mol/l
M_V	Total amount of vanadium needed for battery	mol
N_C	Number of cells in a stack	
N_S	Number of stacks in the battery	
η_{OA}	Overall efficiency of battery	
Δp	Pressure drop	Pa
P	Power capacity of battery	W
q	Heat	W
SOC	State of charge of battery	
τ_C	Time to charge or discharge battery	hr
ΔT	Temperature change of vanadium through stack	$^{\circ}C$
ΔT_{LM}	Log mean temperature difference	
U	Heat transfer coefficient	$W/(m^2 \text{ } ^{\circ}C)$
μ	Viscosity of vanadium solution	$Pa*s$
V_S	Potential of a stack	V
V_T	Volume of tank	l
$X_{V,P}$	Fraction of vanadium ions converted per pass	

CHAPTER 1: Introduction

Introduction

Background

Interest in the development of grid scale energy storage is fueled by a number of potential benefits that could be provided by this type of storage. Grid scale energy storage can be used to store energy during periods of low demand and supply power during periods of peak demand. Electricity generated from intermittent sources such as solar or wind power could be stored and discharged when the source is unavailable. The stabilization of transmission lines and improvement of service reliability for customers could be achieved, and finally grid scale storage could act as a source of uninterruptable power supply for sensitive equipment. Unfortunately practical implementation of grid scale storage has been impeded by issues of high cost and poor performance. Vanadium redox-flow batteries (VRB) represent one promising approach being considered by electric companies to store electric energy

Objective

The objective of this thesis is to provide a methodology for a base case design of a VRB in which the capital costs of the VRB are calculated in a step by step procedure so that unprofitable designs can be identified early, and to provide a capital cost sensitivity analysis so that the components of the VRB that have the greatest contribution to the capital costs can be identified. This type of analyses can provide focus to research activities. The trade-off in cost between factors primarily associated with energy density and electrical power density will provide insight into appropriate priorities for different deployment scenarios, while the design methodology can provide an accurate and convenient method for estimating the capital costs of different VRB designs for the deployment scenarios.

CHAPTER 2: Base Case Design and Capital Cost Estimate of a Vanadium Redox-Flow Battery

Chapter 2 of this thesis is a slightly revised version of an article by the same name that will be published in the journal *Chemical Engineering Education* in 2012 by Mark Moore, Robert M. Counce, Jack S. Watson, Thomas A. Zawodzinski, and Haresh Kamath.

My contribution to this paper included the development of the process, the calculations, and the authorship of the paper. Robert M. Counce and Jack S. Watson provided advice and editing support.

Abstract

The purpose of this work is to develop an evolutionary procedure to be used by Chemical Engineering students for the base-case design of a Vanadium Redox-Flow Battery. The design methodology is based on the work of Douglas (1985) and provides a profitability analysis at each decision level so that more profitable alternatives and directions can be indentified before additional time and effort is expended on an impractical design. Ultimately, a base case flow sheet and capital cost estimate are generated; this type of design activity as the work presented here is referred to as creation and analysis of a study level design.

Introduction

The synthesis of chemical processes distinguishes chemical engineering process design from that of other engineering disciplines. In the work presented here, an approach usually applied to the synthesis of a traditional chemical production process is modified and used in the synthesis of an electro-chemical process for the storage of electrical energy. The intended use of this paper is for the development of case studies and homework problems for the chemical engineering curriculum, especially for the process design components of such a curriculum. It is intended to aid in the education of undergraduate students in the creation of process flow sheets and base-cases for those processes with chemical reactions as a central element. The vanadium redox-flow battery (VRB) has some similarities to standard chemical processes usually studied in chemical engineering classes but offering a chance for the students to see these principles applied to a slightly different situation. As more chemical engineering graduates go to work in a wider variety of industries, they may need a wider experience during their education.

Redox-flow batteries represent one promising approach being considered by electric companies to store electric energy produced during periods of low demand (usually in the evenings) and use the energy during periods of high demand, usually during the day. The VRB was patented by researchers at the University of New South Wales, Australia where development has continued.[1,2,3,4] Other recent reviews of flow batteries are also available.[5,6,7,8,9] Because of the high capital costs for conventional electric energy generation systems, especially for hydroelectric and nuclear systems, it is more economic

to operate such units as much as possible since the fuel costs are essentially zero, or a relatively small part of the total cost. Even for coal combustion systems, the capital costs have risen in recent years because of additional flue gas treatment. Economics usually still favor operating coal combustion systems as “base load” components that operate as much of the time as possible. Base load in this instance refers to the minimum amount of electrical power generated in order to meet the demand. To avoid installing high capital cost power (base load power) to meet peak energy needs, utility companies can use energy storage systems such as VRBs or make short-term use of gas fired generators with high fuel costs but low capital costs. Despite the higher fuel costs, overall costs can be reduced by using the low-capital cost systems for short periods of high power demand.

The design methodology used here is adapted from one developed by Douglas, a step-by-step hierarchical process often used in chemical engineering classes proceeding through decision levels where more details are added to the flow sheet at each step or level of the design procedure.[10] In addition, the capital costs of the battery system are evaluated at each level so that uneconomical designs are eliminated as early as possible and the syntheses efforts can be redirected to more promising directions as early in the design process as possible.

This paper focuses only on the capital costs of the battery system. The assignments to the students ended with an evaluation of the capital costs and did not include the operating costs. As noted earlier, the energy storage devices such as the VRB are attractive because of their potential capital costs are lower than those of base load systems. The electric power industry has set targets for how low capital costs must become, and development efforts are in progress to reach those goals.[11] The goals of the student projects were to determine how close the current or foreseeable technology can come to the target for capital cost and to identify those components of the VRBs that are keeping the cost high and should be targeted for cost improvements. Only after the capital cost of VRBs can be reduced to values near the targets will it be useful to study operating costs in detail. VRBs are likely to be located on the sites of existing electric power plants. Flow batteries have few moving parts (such as pumps) and are usually

suited for automated operations. Maintenance costs are expected to occur from corrosion and maintenance of electrolyte purity, but estimation of these costs are not reliably predicted by normal chemical engineering design practices taught in undergraduate courses and are expected to require pilot operating experience.

The design class was divided into six teams with three to four members per team. Each team considered a base case design and one or more variables/parameters to change. Parameters including membrane cost, efficiency, power capacity, and energy capacity were assigned to the groups. The capital costs for the VRBs were plotted vs these parameters to show the difference that changing these parameters had on the capital costs. This provided a basis for direct comparison of the results from each team and allowed the entire class to consider and observe the effects of different parameters on the capital costs. Each change in a parameter represented a different operating condition or a different cost for a component of the battery.

Background

A schematic of a vanadium redox battery system is shown in Figure 2-1.[12] It may be called a system because it consists of tanks, pumps, and voltage conversion equipment as well as the actual battery cells. The battery cells consist of carbon felt electrodes and a cation exchange membrane (Nafion© 115) which divides the cell into two compartments. One compartment is filled with a solution of V(II) and V(III) ions while the other compartment is filled with a solution of V(IV) and V(V) ions. The vanadium ions are dissolved in sulfuric acid, usually 1 to 2 mol/liter. The electrochemical reactions occurring at each electrode while the battery is being charged are given in equations 1 and 2. The reactions occurring while the battery is being discharged proceed in the opposite direction.

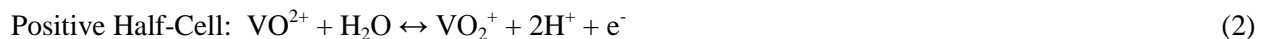

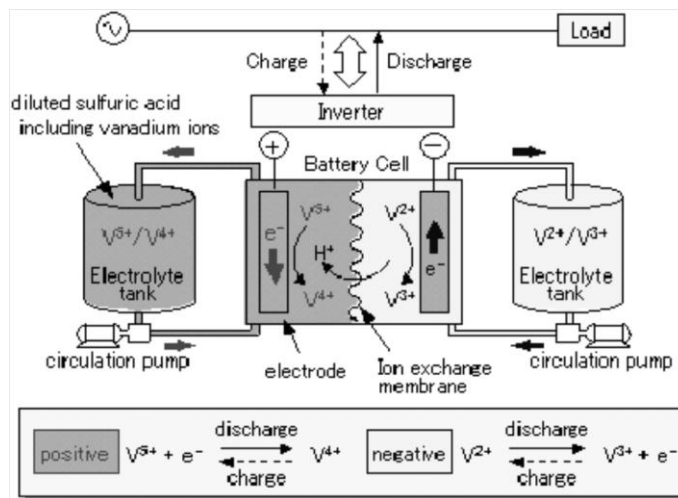

Figure 2-1. Schematic representation of a vanadium redox-flow battery.

Each cell is assumed to produce 1.26 volts at zero current density, and in order to produce high voltages, the cells are stacked in series. As discussed later, inefficiencies reduce the effective voltage to values closer to one volt. Each electrode other than the end electrodes are “bipolar,” with one side acting as a cathode for the cell on one side and as an anode for the cell on the other side. The unique feature of “flow” batteries is the liquid electrolyte, which can flow through the cell. As shown in Figure 2-1, there are two electrolyte solutions; both solutions flow through each cell on different sides of the membrane. The power produced by the battery is determined by the voltage produced (the number of cells in a stack), and the current produced is determined by the current density and the area of the carbon felt electrodes. Voltage can be lost from inefficiencies that may be affected by operating conditions. The total energy storage capacity is determined largely by the volume of the electrolyte solutions, the concentration of vanadium ions in those solutions, and the fraction of the vanadium ions used in any charge-discharge cycle. It is not practical to approach full utilization of all of the vanadium in the solutions. Again, any change in cell efficiencies that affect voltages produced has effects on stored energy recovered.

The decoupling of power and energy capacities in redox-flow batteries creates distinct advantages over other forms of energy storage. It allows for the power and energy capacities to be scaled

independently in order to meet the unique needs of a particular utility. The power capacity required for the battery will determine the size of the cell stacks, the power conditioning system, the pumps, and the heat exchangers. The energy capacity required for the battery will determine the mass of vanadium electrolyte and the size of the storage tanks necessary. The capital costs therefore can be classified here in three areas:

1. Costs that scale in proportion to the power capacity;
2. Costs that scale in proportion to the energy capacity;
3. Costs that do not scale with size (the control system and balance of plant).

The step-by-step hierarchical method created by Douglas consists of several steps that include heuristics for the design of a chemical system. The first step consists of defining the process as continuous or batch, and the second step is an analysis of the raw materials, feed streams, and product streams. The subsequent steps are for analysis of the recycle system, the separation system, and the heat exchanger network. This method used by the students in the design study was adapted to the design of a VRB, keeping in mind the classification of the capital costs into the three areas already discussed:

- Level 1: Input information for the VRB;
- Level 2: Input-output analysis;
- Level 3: Power capacity considerations;
- Level 4: Energy capacity considerations;
- Level 5: Control system, and balance of plant;
- Level 6: Total capital investment estimate;

As with the procedure of Douglas, Levels 2, 3, 4 and 5 include a rudimentary economic (profitability) analysis that is guided by the analysis of previous levels. The profitability analysis is based on the yearly profit produced by running the battery minus the capital expenses at every level annualized over the life of the components. This procedure, as with that of Douglas, allows for economic designs to be recognized quickly and uneconomical designs discarded so the process may begin again at the appropriate level. The procedure culminates in an estimate of total capital investment.

Process Synthesis Hierarchy

Level 1: Input Information for the VRB

The first level of the adapted design methodology for a VRB is the definition of the design specifications for the VRB, as well as the costs for different component parts. To better illustrate the design method, the base case VRB used by the students is defined in Tables 2-1, 2-2, and 2-3. These design variables will be used as an example for calculations throughout this paper except where otherwise noted. The price of product electricity used in Table 2-3 is that needed to bound the spot prices of recent years as reported by the United States (U.S.) Federal Energy Regulatory Commission. This price represents the upper bound of (peak) energy prices and is used here in a comparison mode to develop the base case process. After the base case is determined it would normally be subjected to optimization at near to actual market prices. In this report the base case cost model is examined at near market prices in the final portion of this report.

To calculate the efficiencies for different current densities, data was taken from two graphs from a paper by You et al. and plotted in Figure 2-2.[13] These graphs show that the cell voltage while charging and discharging is dependent on the state of charge (SOC) of the VRB. The SOC defines the concentrations of the reactants and the products at any given point in time and represents the amount of energy the VRB is storing relative to its full capacity. SOC is defined with equations 3 and 4.

$$SOC \equiv \frac{c_{V2+}}{c_{V2+}+c_{V3+}} \text{ for the negative electrolyte, or} \quad (3)$$

$$SOC \equiv \frac{c_{V5+}}{c_{V5+}+c_{V4+}} \text{ for the positive electrolyte,} \quad (4)$$

Graph (a) of Figure 2-2 represents a current density of 40 mA/cm² while graph (b) of Figure 2-2 represents a current density of 80 mA/cm². [13] The area beneath the charging curves represents the

Table 2-1. Reaction Related Information.

Stoichiometry	$V^{3+} + e^- \leftrightarrow V^{2+}$ $VO^{2+} + H_2O \leftrightarrow VO_2^+ + 2H^+ + e^-$
Operating Temperature	25°C
Concentration of Vanadium	1 Molar
Concentration of H ₂ SO ₄	5 Molar
Power Capacity	1,000 kW
Energy Capacity	12,000 kW-hr
SOC Limits	$0.20 \leq SOC \leq 0.80$
Efficiency	0.91
Electrical Potential of a Cell	1.26 volts

Table 2-2. Design Details.

Cycles per Year	328 (90% availability)
Cross Sectional Area of Cell	1 m ²
Current Density of Current Collector	40 mA/cm ²
Material of Construction: Tanks	PVC
Material of Construction: Heat Exchangers	High Ni Steel
Cells in a stack	100 cells/stack

amount of energy used to charge the VRB, and the area beneath the discharging curves represents the amount of energy discharged from the VRB. The ratio of the discharged energy to the charging energy can then be used as the efficiency of that current density for a complete cycle. An assumption was made that the relationship between current density and efficiency was linear. The linear dependence of efficiencies with current density was determined from the data. The ratio of the discharged energy to the energy used to charge for the current densities of 40 mA/cm² and 80 mA/cm², as well as an assumed efficiency of 1 at 0 mA/cm², was used to calculate an equation of a line. The equation is $\eta_{OA} = 1 - 0.0021565x$, where x represents the current density in mA/cm².

Level 1 of the original Douglas procedure includes fundamental design information and whether the process is to be a batch or continuous process. The VRB is considered to be a semi-batch system. The electrochemical cells are converting the vanadium redox species much like a steady-state system, but the feed concentrations to the cells varies with time. This is much like a batch tank with a side stream of

Table 2-3. Cost Information.

Price of Output Power	\$0.45 per kW-hr
Cost of Input Power	\$0.045 per kW-hr
Vanadium Cost	\$25.13 per kg of V
Ion-exchange Membrane	\$500 per m ²
Current Collectors	\$51 per m ²
Carbon Felt	\$20 per m ²

fluid circulating through a reactor. Thus, the work presented here is formulated in a way that is similar to that of Douglas, and Level 1 provides the basic information needed for design. The above input information is a matter of choice and does not necessarily represent an optimal design. The cost information used here is generally appropriate for 2011 U.S. dollars. The current densities and the charge and discharge efficiencies have been assumed to be equal for the example presented here.

Level 2: Input-Output Analysis

The costs of the energy required to charge the battery represents the majority of the cost of operating the battery, while the revenue stream resulting from operating the battery comes entirely from selling the energy discharged by the battery. By considering these costs and revenues, one can gauge the maximum economic potential of the VRB. This is much like a chemical process where the maximum economic potential is the difference between the product value and the raw material cost while neglecting any processing costs.

Equation 5 may be used to calculate the economic potential for level 2. The cycles per year represent a full cycle, i.e. the charging and discharging of the battery.

$$EP_2 = (E_D \times \$/kWh_D - E_C \times \$/kWh_C) \times \text{cycles/year} \quad (5)$$

E_C and E_D are defined by equations 6 and 7.

$$E_C \equiv \frac{E_{SC}}{\xi_C} \quad (6)$$

$$E_D \equiv E_{SC} \times \xi_D \quad (7)$$

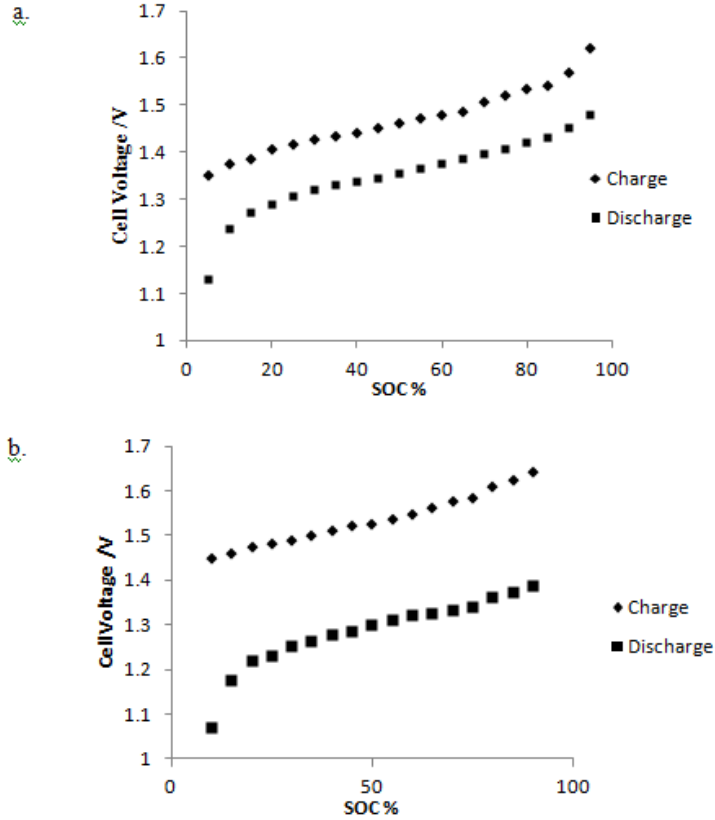

Figure 2-2. The cell voltage at different SOCs for (a) a current density of 40 mA/cm² and (b) and current density of 80 mA/cm².

Example Calculation for Level 2 Economic Potential:

$$E_D = 10,920 \text{ kWh}$$

$$EP_2 = (10,920 \text{ kWh} \times \$0.45 \text{ kWh}^{-1} - 13,187 \text{ kWh} \times \$0.045 \text{ kWh}^{-1}) \times 328 \text{ cycles/year}$$

$$EP_2 = \$1,417,155 \text{ yr}^{-1}$$

The economic potential for cycles of up to 350 per year are plotted in Figure 2-3 for Levels 2 through 5.

Level 3: Power Capacity Considerations

The next major costs of a VRB considered by the students are the power capacity considerations.

The costs that scale with the power capacity of a VRB are the cells themselves, a power conditioning

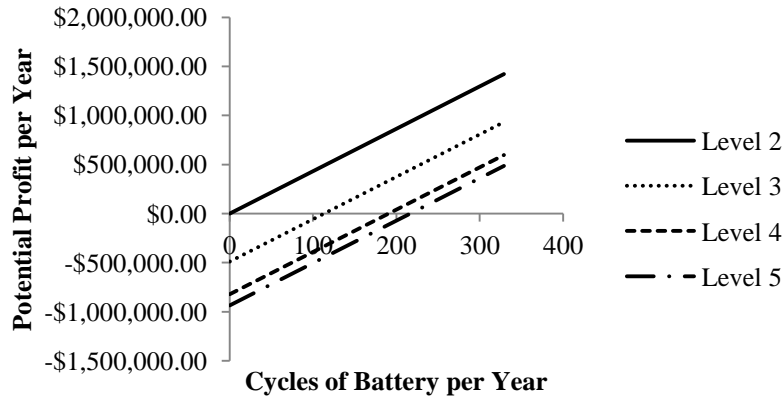

Figure 2-3. Economic Potential for a Vanadium Redox-Flow Battery.

system (PCS) which converts electricity from AC to DC during charging and DC to AC during discharging while adjusting to the desired voltage, the pumps, and the heat exchangers.

The materials used to construct the cells consist of carbon felt electrodes, current collectors, and a membrane permeable to protons. A diagram of the cell construction is presented in Figure 2-4.[12] As noted earlier, the electrical potential of a cell is dependent on the state of charge (SOC) of the vanadium ion solution being pumped through the cell.

Since the SOC is constantly changing during the charge and discharge process, the voltage - and therefore the power - of the VRB is constantly changing. The power rating of the VRB in the design methodology used by the students is the average power of the VRB over the charge/discharge cycle (or at 50% SOC). By using the average power for the design process, the correct energy capacity can be calculated without having to account for the changing voltage over the course of the cycle.

The number of stacks needed is dependent on the current density of the carbon felt electrodes and the number of stacks in the VRB. The current through all the cells in a stack is constant and may be calculated by multiplying the current density of the carbon felt electrodes by their area, as in equation 8.

$$I_S = I_D \times A_C \tag{8}$$

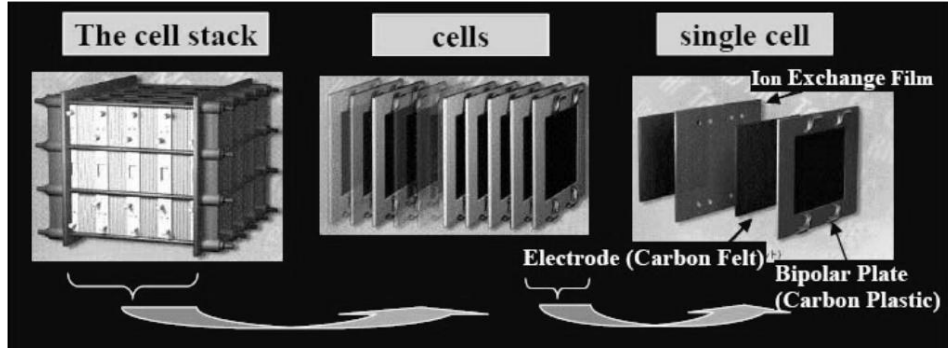

Figure 2-4. Cell Stack Construction.

In the model used by the students, the stacks were connected in parallel. In this manner, the electrical current produced by a stack is additive to the current produced by the other stacks. The electrical potential is determined by the cell potential and the number of cells in a stack, both defined in Level 1 of this methodology. The power capacity of the battery is the electrical potential multiplied by the current capacity of the VRB since the power capacity of the battery is defined in Level 1, the number of stacks can be calculated with equation 9.

$$N_s = \frac{P}{V_s \times I_s \times \xi_c} \quad (9)$$

The power that is lost due to the inefficiencies of the battery is released through heat. The heat generation is based on a total energy balance around the charging or discharging battery and assumes that the only energy removed from this system is by the exit fluid stream. To estimate the heat generated by the VRB, equation 10 may be used for charging the battery and 11 for discharging the battery.

$$q = \frac{P}{\xi_c} \times (1 - \xi_c) \quad (10)$$

$$q = P \times (1 - \xi_D) \quad (11)$$

It is assumed that the heat generated is shared equally between both the cathode solution and the anode solution with the temperature change of the vanadium ion solutions dependent on the flow rate of the vanadium solution through the stack. To calculate the flow rate of the vanadium ion solutions, it is

necessary to calculate the moles of vanadium ions oxidized per second then divide by the molarity of the vanadium ions in the solution, as in equation 12.

$$F_M = \frac{I_S \times N_C \times N_S}{F \times C_V} \quad (12)$$

F_M in equation 12 represents the minimum flow rate if all the vanadium ions in solution are oxidized while flowing through the cells. One of the sources of inefficiency in a flow battery is transport loss, which is associated with the complete conversion of all available vanadium ions flowing through the cell.[14] Because of this, it was recommended to the students that a greater bulk flow of the vanadium ion solution be pumped through the cells than the minimum flow rate required. In the example presented here the minimum flow rate represents 10% of the greater bulk flow rate. The flow rates of both anode and cathode solutions used by the students was calculated with equation 13.

$$F_A = \frac{F_M}{X_{V,P}} \quad (13)$$

With the flow rate, the change in temperature of the cathode or anode solution is calculated by equation 14.[15]

$$\Delta T = \frac{q}{2 \times C_p \times F_A} \quad (14)$$

For estimation purposes, the heat capacity of the sulfuric acid solution is assumed. Because of the increased flow rate of the vanadium ion solution, the temperature rise of the vanadium ion solution may be such that heat exchangers are unnecessary. If the temperature rise during the pass of fluid through the stacks is less than 10⁰C, the heat exchangers will not be considered in the analysis, however some heat exchange may indeed be necessary and will need to be considered before final process design.

If the temperature of the vanadium ion solution necessitates the use of heat exchangers, equation 15 may be used to determine the size of the heat exchangers needed to bring the solution to room temperature.[15]

$$A = \frac{q}{U \Delta T_m} \quad (15)$$

After determining the size of the heat exchangers, the size of the pumps required for the flow rate can be calculated if needed. The shaft power of the pumps can be calculated with equations 16 and 17, for which F_A is in m^3/s (in all other equations F_A is in liters/s).[15]

$$W = \frac{F_A \times \Delta p}{\varepsilon_i} \quad (16)$$

$$\varepsilon_i = (1 - 0.12F_A^{-0.27})(1 - \mu^{0.8}) \quad (17)$$

The students were given an estimate of the cost of the Power Conversion System (PCS) to convert AC power to DC power and to convert the DC product from the battery back to AC power for returning to the electrical grid. The current cost of a PCS is estimated at \$260 per kW. The costs associated with the PCS are for the transformer, breakers, contacts, and cabling, which are estimated by EPRI.[12]

To calculate the economic potential for Levels 3 and beyond, it is necessary annualize the capital costs. The annualized capital costs include the annual expenses, the cost of capital, and equipment depreciation. The annual expenses used here are those that are directly proportional to fixed capital, as listed in Table 2-4.[15]

The cost of capital considers the required return on investment for a given capital outlay. The required return on investment will vary by company but is assumed in this circumstance to be 10%. Annualized interest on invested capital expressed as a fraction of the initial capital investment is calculated with equation 18.[16]

$$f_{RI} = \frac{n \left[\frac{i(1+i)^n}{(1+i)^n - 1} \right] - 1}{n} \quad (18)$$

Table 2-4. Annual Expenses Proportional to Fixed Capital.

Capital-related cost item	Fractions of fixed capital
Maintenance and repairs	0.06
Operating supplies	0.01
Overhead, etc.	0.03
Taxes and insurance	0.03
General	0.01
<i>Total</i>	0.14

$$AC = C_{cost}(0.14 + f_{RI} + f_D) \quad (20)$$

The economic potential for Level 3 can then be calculated with equation 21.

$$EP_3 = EP_2 - AC_S - AC_{HEX} - AC_P - AC_{PCS} \quad (21)$$

Example Calculation of Level 3 Economic Potential:

A summary of the components of the cell stack and their associated costs is given in Table 2-5. A stack consisting of 100 cells contains 101 current collectors (101 m²/stack, total for 20 stacks = 2020 m²), 202 carbon felt electrodes (202 m²/stack, total for 20 stacks = 4040 m²), and 100 membranes (100 m²/stack, total for 20 stacks = 2000 m²). Added into the total costs for the stacks are manufacturing costs, shipping costs, and additional costs which were assumed to be 20%, 10%, and 10% respectively of the total capital costs of the components.[12] The annualized costs of an equipment item are the annualized costs of the installed equipment items; an installation factor of 1.4 is used to modify the purchased costs of the stacks. Figure 2-3 shows that at Level 3 it is necessary to cycle the battery over 100 times a year in order to make a profit. The economical potential drops by over \$500,000 between Levels 2 and 3, which is significant. Examining the costs of components in Table 2-5 shows that the bulk of this drop in economical potential is due to the costs of cell ion exchange membranes.

$$EP_3 = \$1,417,155 \text{ yr}^{-1} - \$501,754 \text{ yr}^{-1} - 0 - \$19,303 \text{ yr}^{-1} - \$26,070 \text{ yr}^{-1}$$

$$EP_3 = \$870,027 \text{ yr}^{-1}$$

Level 4: Energy Capacity Considerations

The energy capacity of a VRB is determined by the mass of vanadium electrolytes in each solution. The stoichiometric equations listed in Level 1 show that one 1 mole of vanadium ions will

produce one mole of electrons when oxidized or reduced. Because of this, the students calculated the moles of vanadium ions needed by taking the moles of electrons oxidized by one cell in one second, multiplying by the charge time, multiplying by the number of cells in a stack, then multiplying by the number of stacks in the battery as in equation 22.

$$M_V = \frac{I_S \times \tau_C \times N_C \times N_S}{F} \quad (22)$$

This calculation will provide the moles of vanadium electrolytes needed for the cathode or the anode solutions and should be multiplied by two for the total amount needed. To calculate the amount of vanadium needed, however, changes in the SOC of the battery must be considered. As mentioned in Level 3, the electrical potential as a function of the SOC increases as the SOC increases. The VRB cannot be fully charged without using very high (infinite) voltages and cannot be fully discharged without a severe loss of voltage (efficiency) in the discharge. It is assumed that the base-case battery will operate between a SOC of 0.20 and 0.80, which means that M_V represents 60% of the total vanadium needed.

The tanks used to store the vanadium solution will vary in size with the volume of vanadium ion solution needed, and therefore with the energy capacity of the VRB. Because of the corrosive nature of sulfuric acid, the use of double-walled tanks should be considered. In the current example, the students used single-walled fiberglass tanks. The size of the tanks and amount of vanadium needed is estimated by equations 23 and 24 (in the current example one liter of solution contains one mole of vanadium).

$$V_T = \frac{M_V}{M_U - M_L} \quad (23)$$

$$M_T = \frac{2 \times M_V}{(0.6)} \quad (24)$$

The economic potential for Level 4 is then calculated with equation 25.

$$EP_4 = EP_3 - AC_V - AC_T \quad (25)$$

Table 2-5. Level 3 Capital Costs.

Membrane Area (20 Stacks)	2000 m ²
Cost of Membrane	\$500 m ⁻²
Total Cost of Membrane (20 Stacks)	\$1,000,000
Cost of Current Collectors	\$51 m ⁻²
Total Cost of Current Collectors (20 Stacks)	\$103,020
Cost of Carbon Felt Electrodes	\$ 20 m ⁻²
Total Cost of Carbon Felt Electrodes	\$80,800
Total Cost of Stacks (20 Stacks)	\$1,657,348
Annualized Cost of Stacks (20 Stacks)	\$501,754
Cost of Pumps (2)	\$86,112
Annualized Cost of Pumps (2)	\$26,070
Cost of Power Conditioning System	\$260 kW ⁻¹
Transformer Cost	\$36.58 kW ⁻¹
Cost of Breakers, Contacts, and Cabling	\$28.14 kW ⁻¹
Total PCS and Associated Items Cost	\$324,720
Annualized Cost of PCS and Associated Items	\$19,303
Total Annualized Cost of Level 3 Components	\$547,127

This Level 4 methodology differs significantly from the method suggested by Douglas. He uses Level 4 for including the costs of separation systems in a chemical process. This is one place where a change was needed to the Douglas approach for the VRB.

Example Calculation for Level 4 Economic Potential

A summary of the components associated costs with Level 4 considerations is presented in Table 2-6. To account for the costs of preparing the solution, the capital cost of the vanadium was multiplied by 1.1. To annualize the costs it was assumed that the tanks, vanadium, and sulfuric acid could be used throughout the lifespan of the battery. A reasonable estimate for this lifespan of twenty years was used by the students.[12] The drop in economic potential between Levels 3 and 4 is over \$400,000, and Figure 2-3 shows that it is necessary to have over 200 cycles per year in order to make a profit.

$$EP_4 = \$870,027 \text{ yr}^{-1} - \$393,519 \text{ yr}^{-1} - \$68,217 \text{ yr}^{-1}$$
$$EP_4 = \$408,292 \text{ yr}^{-1}$$

Level 5: Balance of Plant

The last of the major costs of a VRB are associated with the balance of plant costs. These costs may also be associated with the power and energy capacity of the VRB, but are included in another level for simplicity.

The balance of plant costs are based on the EPRI calculations and include the costs for construction (not already accounted for), costs for the control system, and building and site preparation costs.[12] Building and site preparation costs are estimated on average to be around \$900 per square meter of the facility in 2007. Accounting for an inflation rate of 3%, the cost in 2011 is \$1012 per square meter. An estimate for the size of the facility is 500 m²/MW.[12] Adjusting for inflation, the control system is estimated at \$22,509 and the remaining costs are \$56/kW.

$$EP_5 = EP_4 - AC_{BP} \quad (26)$$

Level 5 is not comparable to any level of the Douglas model. It is used to essentially capture all the remaining capital costs elements that are not functions of power or energy.

Example of Level 5 Annualized Capital Costs Estimation:

$$EP_5 = \$408,292 \text{ yr}^{-1} - \$150,487 \text{ yr}^{-1}$$

$$EP_5 = \$257,804 \text{ yr}^{-1}$$

Level 6: Capital Investment Estimate

The last step makes use of the information gathered in the earlier steps to create a capital investment estimate table. A table from the example is presented in Table 2-7. This methodology has covered only the capital costs of a VRB; the operating costs were not included in the student assignments. While a complete summary of the total costs of operating a VRB would include the operating costs, the intent of this design methodology was to include only the capital costs.

Table 2-6. Level 4 Capital Costs.

Concentration of Vanadium	1 mol/L
Volume of Solution	596,984 L
Cost of Vanadium	\$25.13 kg ⁻¹
Total Cost of Vanadium Solution	\$1,528,470
Annualized Cost of Vanadium Solution	\$393,519
Tank Size	656,680 L
Total Cost of Tanks	\$264,960
Annualized Cost of Tanks	\$68,217

Future Possible Cost Reductions

Table 2-7 shows that the cost of the cell stacks and the cost of vanadium were identified as major contributors to capital cost. In this section the possibility of cost reduction for these two variables is explored. The reduced cost of \$35/m² for ion exchanged membranes reflects one author's expected reduction in manufacturing cost caused by increased demand for membranes and improved manufacturing.[9] The reduced cost of vanadium at half of the value in Table 2-3 may be more optimistic, but it is based on the observed volatility of vanadium prices in recent years as reported by the U.S. Geological Survey. The economic potential in the following analysis is based on a more realistic market value of electricity.

The capital cost elements of the base case model reported in Tables 2-1, 2-2 and 2-3 are only changed by the reduction of ion exchange membrane costs in the results shown in Table 2-8. The capital costs per MWh is reduced to \$262. The economic potential of the reduced cost system shown in Figure 2-5 is based on the price of product electricity of \$0.10/kWh and a purchased cost of \$0.01/kWh and shows that the cost of Level 4 and 5 are always negative, indicating no opportunity for profit at the conditions of the study.

The capital costs elements of the base case model reported in Tables 2-1, 2-2, and 2-3 are changed by both the reduction of ion exchange membrane costs and reduced vanadium costs in the results shown in Table 2-9. The capital costs per MWh is reduced to \$198. The economic potential of the reduced cost system shown in Figure 2-6 is based on the price of product electricity of \$0.10/kWh and

Table 2-7. Capital Cost Estimate.

Equipment ID	Number	Capacity	Purchased Cost	Installation and Material Factor	Capital Investment
Cell Stacks (100 cells per stack)	V-101	20 stacks	\$1,183,120	1.4*	\$1,657,348
Vanadium Solution	S-101	596,984 liters	\$1,528,470		\$1,528,470
Tanks	T-101	656,680 liters, Fiberglass	\$88,320	3	\$264,960
Heat Exchanger	C-101	Na	0	4	0
Pumps	P-101	7.9 Watts	\$11,482	7.5	\$86,112
PCS System and Associated Costs	E-101	1,000 kVA	\$324,720	1	\$324,720
Balance of Plant Costs			\$584,509	1	\$584,509
Total Cost			\$3,720,621		\$4,446,119

* for manufacturing costs, shipping costs, and additional costs

purchased cost of \$0.01/kWh and shows that the improved cost of Level's 4 and 5 are still always negative, introducing not opportunity for profit at the conditions of the study.

The results shown here indicate that reduced costs for ion exchange membranes and vanadium do not appear to be sufficient to make the system profitable at the conditions of this study. Additional cost reductions will be necessary. Such cost reductions may be found in activities such as increasing the range of SOC values for system operation and improving the cell current density and efficiency as well as other general cost reductions.

General Observations

Our current CBE process design classes consist of two senior classes (CBE 480 and 488 or 490). CBE 488 is the honors version of CBE 490 and typically has industrial sponsorship. CBE 480 covers fundamental chemical process design: process creation and definition, flow sheet development, design Vasudevan [15] with supplemental information on flow sheet creation by Douglas.[10] CBE 488/490 are both traditional capstone design projects with the primary deliverables being oral and written design

Table 2-8. Capital Cost Estimates at Reduced Ion Exchange Membrane Cost.

Equipment ID	Number	Capacity	Purchased Cost	Installation and Material Factor	Capital Investment
Cell Stacks (100 cells per stack)	V-101	22 stacks	\$276,709	1.4*	\$387,393
Vanadium Solution	S-101	650,820 liters	\$1,666,307	1	\$1,666,307
Tanks	T-101	656,680 liters, Fiberglass	\$88,320	3	\$264,960
Heat Exchanger	C-101	na	0	4	0
Pumps	P-101	20 Watts	\$11,482	7.5	\$86,112
PCS System and Associated Costs	E-101	1,000 kVA	\$324,720	1	\$324,720
Balance of Plant Costs			\$584,509	1	\$584,509
Total Cost			\$2,952,047		\$3,314,001

* for manufacturing costs

and costing of equipment, optimization, economic analysis, and reporting; the textbook is by Ulrich and reports. Both CBE 480 and CBE 488 or 490 are required 3-semester hour classes. The case study presented here was the primary focus of CBE 488 and a shortened version used as a homework problem in CBE 480. Different CBE 488 teams had different design variables, such as current density, in addition to a common base case to study on which to report.

The development of the case study presented here was sponsored by EPRI. One of the co-authors of this study, Haresh Kamath, was a primary author of an authoritative study of all-vanadium redox flow batteries (EPRI - 1014836).[12] Mr. Kamath was instrumental in the study reported here as well as the design of the problem statement for the students, discussion and explanation of system details, and review of the final presentations and reports. Several students stayed for continued discussion with Mr. Kamath and other EPRI personnel after the final presentation; all students approved the transmission of their final report to EPRI. One of the authors of this paper and expert on electrochemical technology, Dr.

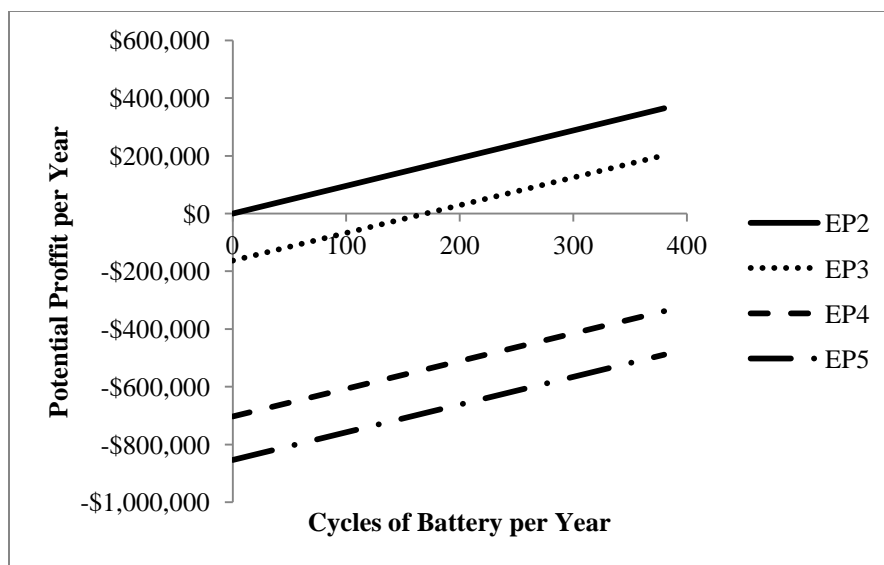

Figure 2-5. Economic Potential for a Vana Redox-Flow Battery at Reduced Membrane Cost Conditions.

Zawodzinski, gave lectures on electrochemistry and electrical storage batteries in CBE 480. The roles of EPRI, Mr. Kamath, and Dr. Zawodzinski added authenticity to the project.

The students had a unique opportunity to do process design work on an electrochemical process; they were also exposed to experts in the field. They were surprised at the scale of existing and planned electro-chemical storage facilities and the relationship between mass and energy balances that is facilitated by the flow of electrical energy. The students also learned that the economics of electrochemical processes may be analyzed similarly to chemical processes. In general, the students appeared to receive the project very well as indicated with an overall student evaluation of CBE 488 as 4.6/5.0. If used again, the future studies may focus on different battery chemistries. The study may also be shortened for use in a Mass and Energy Balance class or a Green Engineering class.

Conclusions

Working through the six levels of this design procedure allowed the students to modify the chemical engineering design procedures which are the standard for a chemical engineering education. Applying these traditional procedures to a non-traditional system gave valuable experience needed to a

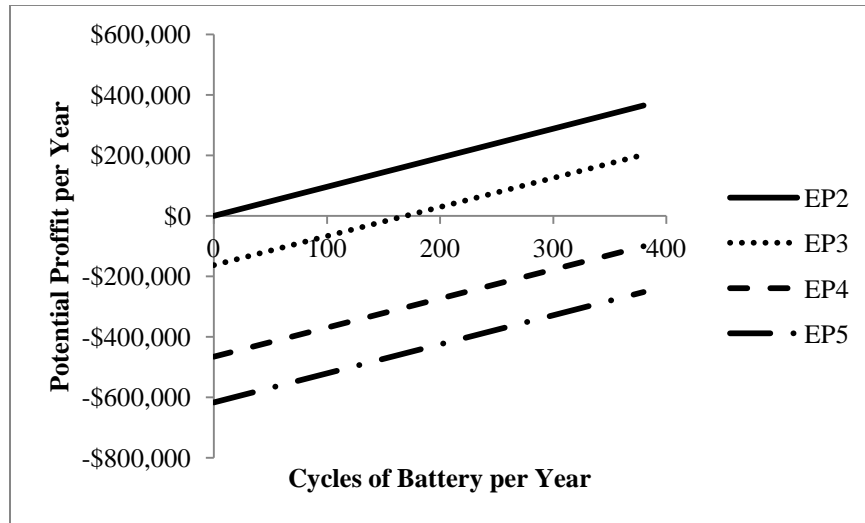

Figure 2-6. Economic Potential for a Vanadium Redox-Flow Battery at Reduced Membrane Cost Conditions and Reduced Vanadium Cost.

field that is no longer restricted to the petroleum or chemical industries. In addition to the experience of applying chemical design principles to a different type of system, the students also received insight into the electric utility industry.

The potential profit at Level 2 and above is shown in Figure 2-3 for the original study conditions. The figure shows the annual profits (the y-axis) at each level for an increasing number of charge/discharge cycles per year (the x-axis). The students concluded that capital costs were such that it would be difficult to construct and operate a VRB at a profit and because of this, there is no need to look into the details of the operating costs until the capital costs can be lowered. The two largest contributions to the capital costs found by the students were the cost of the permeable membrane and the cost of the vanadium electrolyte. Any future developments will need to decrease these costs to make the investment in a VRB more attractive. The potential profit from a VRB was also found to be strongly affected by the cost of peak power electricity. Since the students assumed a ten-fold difference between the cost of base-load power to feed the battery and peak load power produced by the battery, further reductions in the cost of base-load power would have limited effects. The cost analysis presented here does appear to be

sufficient evidence that further process improvements may indeed make the VRB a commercially viable technology.

Works Cited

1. Sum, E.; Skyllas-Kazacos, M. Investigation of the V(V)/V(IV) system for use in the positive half-cell of a redox battery. *J. Power Sources* **1985**, *16* (2), 85-95.
2. Sum, E.; Rychcik, M. A study of the V(II)/V(III) redox couple for redox flow cell applications. *J. Power Sources* **1985**, *15* (2), 179-190.
3. Linden, D., Reddy, T. B., Eds. *Handbook of Batteries*, 3rd ed.; McGraw-Hill: New York, 2002.
4. Li, X.; Zhang, H.; Mai, Z.; Vankelecom, I. Ion exchange membranes for vanadium redox flow battery (VRB) applications. *Energy Environ. Sci.* **2011**, No. 4, 1147-1160.
5. Skyllas-Kazacos, M.; Chakrabarti, M. H.; Hajimolana, S. A.; Mjalli, F. S.; Saleem, M. *The Electrochem. Soc.* **2011**, *158* (8), R55-R79.
6. Weber, A. Z.; Mench, M. M.; Meyers, J. P.; Ross, P. N.; Gostick, J. T.; Liu, Q. Redox flow batteries: a review. *Journal of Applied Electrochemistry* **2011**, *41* (10), 1137-1164.
7. Yang, Z.; Zhang, J.; Kintner-Meyer, C. W.; Xiaochuan, L.; Choi, D.; Lemmon, J.; Liu, J. Electrochemical energy storage for green grid. *Chem Rev* **2011**, *111* (5), 3577-3613.
8. Menictas, M.; Cheng, M.; Skyllas-Kazacos, M. Evaluation of an NH₄VO₃-derived electrolyte for the vanadium-redox flow battery. *J Power Sources* **1993**, *45* (1), 43-54.
9. Kear, G.; Shah, A. A.; Walsh, F. C. Development of the all-vanadium redox flow battery for energy storage: a review of technological, financial and policy aspects. *Int. J. Energy Res.* **2011**.
10. Douglas, J. M. A hierarchical decision procedure for process synthesis. *AIChE J* **1985**, *31* (3), 353-362.
11. NETL homepage <http://www.netl.doe.gov/technologies/coalpower/fuelcells/seca/>.
12. *Vanadium Redox Flow Batteries: An In-Depth Analysis*; EPRI: Palo Alto, 2007.
13. You, D.; Zhang, H.; Chen, J. A simple model for the vanadium redox battery. *Electrochim Acta* **2009**, *54*, 6827-6836.
14. Aaron, D.; Tan, Z.; Papandrew, A.; Zawodzinski, T. Polarization curve analysis of all-vanadium redox flow batteries. *J Appl Electrochem* **2011**, *41*, 1175-1182.
15. Ulrich, G.; Vasudevan, P. *Chemical Engineering Process Design and Economics: A Practical Guide*, 2nd ed.; Process Publishing: Durham, 2004.
16. NCEES. *Fundamentals of Engineering Discipline Specific Reference Handbook*, 3rd ed.; National Council of Examiners for Engineering and Surveying: Clemson, 1997.

CHAPTER 3: Capital Cost Sensitivity Analysis of an All-Vanadium Redox-Flow Battery

Chapter 3 of this thesis is a slightly revised version of an article by the same name that will be published in the *Journal of the Electrochemical Society* in 2012 by Mark Moore, J. S. Watson, Thomas A. Zawodzinski, Mengqi Zhang, and Robert M. Counce.

My contribution to this paper included the development of the cost model, and the authorship of the paper. Mengqi Zhang developed the capital cost function based on my cost model, and calculated the relative sensitivity indexes. Robert M. Counce and Jack S. Watson provided advice and editing support.

Abstract

Interest in the development of redox-flow batteries (RFBs) for large-scale grid storage is growing, and considerable investments have been made into the research and development of RFBs over the past few decades. Unfortunately, practical implementation has been hampered by various cost and performance issues typical of an immature state of development. One critical factor for the competitiveness of this technology is the installed cost. In this work, we incorporate recent developments in all-vanadium RFBs research and present an analysis of the associated cost factors. The major components of a RFB that affect installed cost are identified and used as variables to create a capital cost function. The function is then used to calculate the rate of change of the capital costs with respect to the major components. The capital costs are also calculated for a range of component values and plotted. Key findings include a high sensitivity of system capital cost to purity of vanadium and substantial fractions of the cost associated with perfluorosulfonic acid membranes currently used for proton transport.

Introduction

Redox flow batteries (RFBs) are being developed for use in large-scale electrical grid storage. There are a number of potential benefits that could be provided by large-scale electrical grid storage RFBs. RFBs could be used to store energy during periods of low demand and supply power during periods of peak demand, forgoing the need for additional expensive investments in generating capacity to meet peak demand. Also, electrical energy generated from renewable resources such as wind or solar could be stored in a RFB for use when supplies of renewable power are limited. RFBs could help stabilize transmission lines, act as an uninterruptable power supply for sensitive equipment, and improve service reliability for customers [1]. In spite of

research and development over the past few decades, however, practical implementation is hampered by various cost and performance issues typical of an immature state of development of the technology.

One critical factor for competitiveness of this technology is its installed (capital) cost. ARPA-e targets capital costs of \$100/kWh installed, an aggressive target for lowering the capital costs. Analysis is needed to consider if it is even feasible to meet this kind of target with current technology and to evaluate the changes that are most likely to result in large reductions in capital cost. Thus, economic analyses can provide focus to research activities. For example, the trade-off in cost between factors primarily associated with energy density (redox couples, achievable concentrations of electrolyte solutions) and electrical power density (electrochemical converter performance) will provide insight into appropriate priorities for different deployment scenarios.

In this work, we present an analysis of the cost factors associated with vanadium redox flow batteries (VRBs), which are widely viewed as a possible target technology. We previously analyzed VRB systems using chemical process engineering design strategies [2,3]. The major variables affecting the capital costs are identified.

Background

A VRB is a system utilizing a redox reaction to both charge and discharge the battery by means of a flow of the reactants through the electrochemical cells, see Figure 3-1.[4] Each cell is divided into half-cells by means of a membrane permeable to protons, while the cell itself contains electrodes that collect or provide electrons for the redox reaction. The cells are arranged in stacks and connected in series to increase the electrical potential of the VRB, while stacks are connected in parallel to increase the current capability of the VRB. The redox reaction for the VRB is provided by two solutions of vanadium ions pumped through the cell stacks from storage tanks external to the stack. The tanks store the solutions and, thus, the energy supply for the stack.

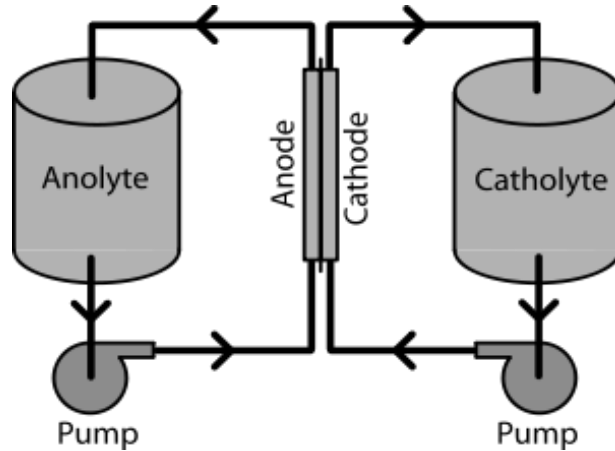
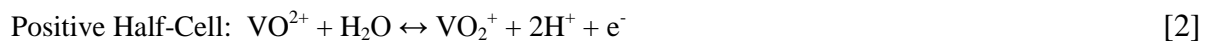

Figure 3-1. Schematic representation of a vanadium redox –flow battery.

The solution pumped through the negative half-cells contains V^{2+} and V^{3+} ions and the solution pumped through the positive half-cell contains V^{4+} and V^{5+} ions. Vanadium is dissolved in sulfuric acid to a typical concentration of one molar. The redox reactions occurring in the half cells while the battery is being charged are:



During discharge, the reactions are simply the reverse of these reactions.

The approach presented here for evaluating the sensitivity of the overall costs of a VRB to the selected design variables is taken, in part, from a paper by Moore, et al. in which a hierarchical method is used in the design process [5]. The core of this method is the categorization of the capital costs into identifiable areas that are examined in a step-by-step procedure, with each step building upon the previous step. The categories presented for analysis of the capital costs are:

1. Costs that scale in proportion to the power capacity;
2. Costs that scale in proportion to the energy capacity;
3. Costs that do not scale with size.

The first two categories constitute the greater portion of the capital costs of the battery and will be the areas in which the cost sensitivity analysis will focus.

The electrical power capacity is determined by the design of the cell stacks. The amount of electric current produced by a cell is dependent on the current density of the cell and the active electrode area. The cells in a stack are assumed to be identical, however, and the cost model presented here does not allow for any change in current through a stack. The desired voltage is achieved by selecting the appropriate number of cells in a stack. The electrical potential of a stack is increased when the cells in a stack are connected in series. Each cell adds to the electrical potential of the stack by the value of the added cells electrical potential. The desired total current is achieved by changing the area of the cells in a stack or by connecting additional cell stacks in parallel.

The electrical power of the VRB is dependent on the overall number of cells in the battery. The current capacity of a cell, thus the current capacity of a stack, is calculated by multiplying the current density of the electrode by the active electrode area. The current capacity of the VRB is calculated by multiplying the current capacity of a cell by the number of stacks, and the electrical potential of the battery is calculated by multiplying the electrical potential of one cell by the number of cells in a stack. The electrical power is then the product of the current capacity and the electrical potential.

The energy capacity of the VRB is determined by the concentration of vanadium and the volume of the process solutions. For a fixed concentration of vanadium, the greater the volume of the solutions, the more energy can be stored by the battery. Larger volumes will be required for battery designs that require a higher electrical energy capacity or a longer cycle time at a given power. An important consideration associated with the energy capacity of the VRB is the state of charge (SOC). The SOC defines the concentrations of the reactants and the products at

any given point in time and represents the amount of energy the VRB is storing relative to its full capacity [6]. The SOC of the VRB is considered because the electrical potential of the battery is dependent on the SOC. This is illustrated by Figure 3-2, which shows the relationship of the electrical potential to the SOC [6,8]. While the graph of the cell potential in Figure 3-2 approaches the boundaries asymptotically, the middle of the graph is approximately linear. It is therefore advantageous to set the limits of the SOC for the VRB within this middle region, where the dramatic drop-off or increase in electrical potential can be avoided.

In addition, narrowing the limits of the SOC provides a smaller range of fluctuation in the power of the VRB. Any change in the SOC during a pass of solution through the cell stack will result in reduced efficiencies since the conducting electrodes will produce only the lower voltage from the exit conditions.

To minimize the inefficiencies, the solution flow rates were maintained sufficiently high so that only incremental changes in the SOC occurred during a single pass through the stack. Thus, the SOC corresponds to a gradual change in the composition in the solution tanks with time as the vanadium ions are oxidized or reduced.

Method

The sensitivity analysis begins by defining a base case VRB. In this paper, the base case is based upon the following conditions:

A. Reaction Related Information

- a. Stoichiometry (See Equations 1 and 2 above)
- b. Temperature: Near room temperature (25°C)
- c. Concentration of vanadium: 1 M
- d. Concentration of H₂SO₄: 5 M
- e. Electrical power capacity : 1,000 kW
- f. Energy capacity: 12,000 kWhr
- g. Cycle time (for charge or discharge): 12 hr
- h. State of charge considerations: Minimum = 0.20, Maximum = 0.80
- i. Average Potential of cell: 1.26 Volts [6]
- j. DC to DC efficiency: 0.91

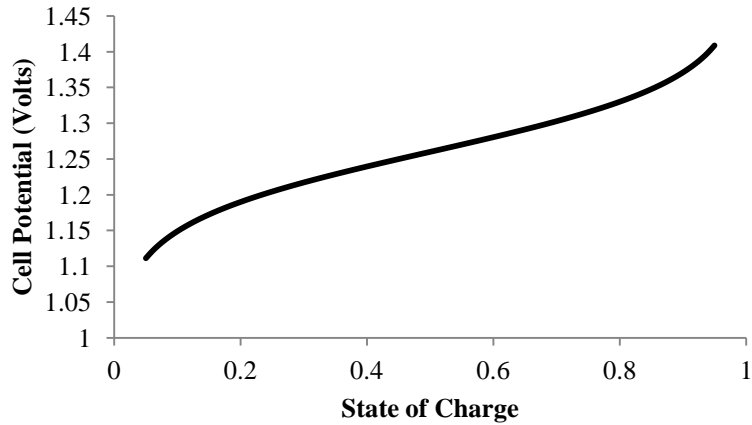

Figure 3-2. The effect of SOC on cell electrical potential.

B. Design Details

- a. Size (cross-sectional area) of cell: 1 m²
- b. Cell stack size: 100 cells
- c. Design current density of cell: 40 mA/cm²
- d. Materials of construction for tanks and heat exchangers: PVC and high Ni steel
- e. Temperature adjustment in flow from cell stack: 15 °C

C. Cost Information

- a. Industrial Grade Vanadium cost: \$21.13/kg of V [7]
- b. Cell Construction Materials [8]
 - i. Ion-exchange membrane: \$500/m²
 - ii. Electrodes: \$51/m²
 - iii. Carbon felt: \$20/m²
- c. Costs are in 2011 U.S. dollars

The capital cost of this base case is about \$4.5 million, or about \$380 per kWh. The costs of the components as a percentage of total capital costs can be seen in Figure 3-3.

From the above base case variables a mathematical model was derived using the costs of different components of a VRB. The components are categorized according to their relationship to the electrical power capacity and energy capacity of the VRB. The variables chosen that are associated with the electrical power capacity of the VRB are the membrane cost and the current density. The variables chosen that are associated with the energy capacity of the VRB are the cycle time, the cost of the vanadium electrolyte, and the limits for the state of charge. The

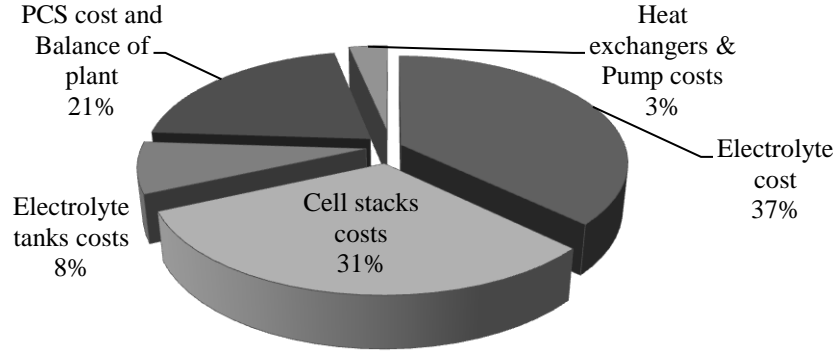

Figure 3-3. The Capital Costs of the Base Case VRB.

mathematical model derived is represented as a function of the components that affect the overall capital costs, taken as variables, in equation 3:

$$\begin{aligned}
 \text{Overall capital costs} &= 3016.9 \times \frac{\tau_c \text{ (hr)} \times P \text{ (W)} \times C_v \text{ (\$/g)}}{(0.8 - S_{CL}) \times \eta_{OA}} + 0.794 \\
 &\times \frac{P \text{ (W)} \times (5151 + 202 \times C_M \text{ (\$/m}^2\text{)} + 100 \times C_M \text{ (\$/m}^2\text{)})}{I_D \text{ (mA/cm}^2\text{)} \times \eta_{OA}^2} \\
 &+ 355707.36 \times \left(\frac{\tau_c \text{ (hr)}}{12}\right)^{0.6} \\
 &+ 830.72 \times \frac{P \text{ (W)}}{\eta_{OA}} + 22509 \\
 &+ 1227.6 \times \left(\frac{P \text{ (W)}}{\eta_{OA}}\right)^{0.6} + 15268.4 \times \left(\frac{P \text{ (W)}}{\eta_{OA}}\right)^{0.22} \quad [3]
 \end{aligned}$$

See Table 3-1 for variable definitions. With this function the relative sensitivity index can be defined by equation 4:

$$\text{Relative sensitivity index} = \text{abs}\left(\frac{df}{dx}\Big|_{BCP} \times \frac{x_0}{f_0}\right) \quad [4]$$

where BCP is the base case point, x is the cost component variable, f is the capital cost function, x_0 is the component variable at the base case, and f_0 is the overall capital cost at the base case.

Table 3-1. Nomenclature.

Variable	Description	Units
τ_c	Time necessary to fully charge or discharge the VRB.	hr
P	Power capacity of the VRB.	W
C_V	Cost of the vanadium ions.	\$/g
S_{CL}	Lower limit of the SOC.	
η_{OA}	Overall efficiency of the VRB (DC to DC).	
C_M	Cost of the membrane.	\$/m ²
I_D	Current density.	mA/cm ²

The relative sensitivity index is then a measure of the rate of change of the capital costs for a particular component variable at the base case values. Since the absolute value of the equation is taken, the higher the result, the greater the variable's influence on overall capital costs. We take the variables, such as the current density, cycle time, membrane cost and vanadium cost, into consideration and list the corresponding relative sensitivity index in Table 3-2.

Other than the relative sensitivity analysis, we start with the base case values to understand the effects of changing variable values of a certain range; the variables are selected individually and given a range of values. The capital costs of the VRB are then calculated for each of these values and divided by the energy capacity of the VRB to attain the value for capital cost per kilowatt -hour for comparison to the ARPA-e goal of \$100/kwh. The costs for the tanks, pumps, and heat exchangers were taken from a textbook by Ulrich [9].

The cost for the permeable membranes represents the majority of the costs for the cell stacks of a VRB. In the base case scenario, it alone represents about one-fourth of the total capital costs for the VRB. To test the sensitivity of the system cost to the membrane cost, the total

Table 3-2. Summary of Relative Sensitivity Indexes.

Relative Sensitivity Index		
	Current Density	0.3092
	Cycle Time	0.6101
Fixed Power	Membrane Cost	0.2612
Capacity Variables	Electrode Cost	0.021
	Vanadium Cost	0.3337
	Lower SOC Limit	0.1112
Fixed Energy	Power Capacity	0.4881
Capacity Variables	Cycle Time	0.4881

capital costs for the VRB were calculated for membrane costs ranging from \$100/m² to the base case cost of \$500/m².

The current density of the electrodes has a significant effect on the number of stacks required. When the size of the cell is constant, the added current capacity increases the current through the stack, requiring fewer stacks in order to meet the electrical power requirement. The total capital costs were calculated for a range of current densities of 20 mA/cm² to 100 mA/cm². The increase in current density of the electrodes increases the over potential during charging and lowers the potential during discharge, and thus lowers the efficiency of the VRB. To calculate the efficiencies for different current densities, data was taken from two graphs from a paper by You [10]. Graphs plotted from the data can be seen in Figure 3-4. These graphs show that the cell voltage while charging and discharging is dependent on the SOC of the VRB. Graph (a) represents a current density of 40 mA/cm² while graph (b) represents a current density of 80 mA/cm². The area beneath the charging curves represents the amount of energy used to charge the VRB, and the area beneath the discharging curves represents the amount of energy discharged from the VRB.

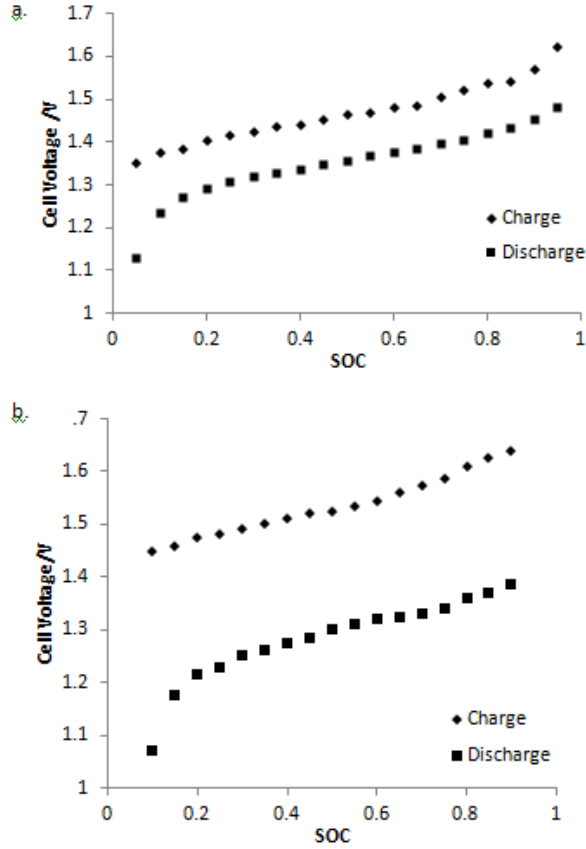

Figure 3-4. The cell voltage at different SOC for (a) a current density of 40 mA/cm² and (b) a current density of 80 mA/cm².

The ratio of the discharged energy to the charging energy can then be used as the efficiency for that current density. An assumption was made that the relationship between current density and efficiency was linear. The linear dependence of efficiencies with current density was determined from the data at 40 mA/cm² and at 80 mA/cm² and an assumed efficiency of 1 at 0 mA/cm². This equation was calculated to be:

$$\eta_{OA} = 1 - 0.0021565 \times x \quad [5]$$

where x represents the current density in mA/cm².

The cycle time determines the amount of energy the VRB must store; the longer the cycle time, the greater the mass of vanadium electrolyte required to store the energy. The sensitivity of the overall capital costs to the cycle time is examined by holding the electrical power of the VRB at the base case value and changing the charge and discharge time for values between from 4 hours to 12 hours (total cycle time from 8 hours to 24 hours).

The major cost associated with the energy storage capacity of the VRB is the cost of the vanadium electrolyte, which at the base case value represents about 40% of the capital costs of the entire battery [11]. The base case, however, assumes industrial grade vanadium while most research into VRB has been done in the laboratory with a higher grade of vanadium. The higher grade of vanadium is significantly more expensive. If deployment of VRBs increases the demand for higher grade vanadium, the cost for higher grade vanadium could fall, possibly to prices somewhere between the current cost for low grade and current costs for higher grade vanadium. To examine the effects of this on the capital costs of a VRB, the costs of the vanadium were varied from the industrial base case value of \$0.021 per gram to the laboratory grade value of \$2.10 per gram.

As the SOC range becomes narrower, there is a need for a greater capacity of the vanadium electrolyte since less vanadium is utilized during each cycle. To examine the effect of this on the total capital costs of the VRB, the upper SOC limit is held at 0.8 while the lower SOC limit ranges from 0.2 to 0.7. For this study, the electric current density was a parameter of interest, so in all cases, the battery was charged and discharged at a constant current density. The energy capacity of a VRB is a product of the power capacity and the cycle time. It is the amount of power (in kW) applied over a certain period of time (hours), and is measured in kilowatt-hours. If the energy capacity of a VRB is held constant, an increase in the power will provide for a decrease in the cycle time for the battery, while an increase in the cycle time will provide for a decrease in the power. The increase in power capacity requires the addition of stacks of cells, increasing the capital costs associated with the power capacity. The cycle time

influences the amount of vanadium electrolyte required as well as the size of the tanks, which affects the capital costs as well. To see the effects on the capital costs when power capacity increases and the cycle time decreases, the energy capacity is held constant while the power ranges from 1000 kW to 3000 kW and the charge/discharge time ranges from 12 hours to 4 hours (a total cycle time of 24 to 8 hours).

Results

The values of the relative sensitivity index are given in Table 3-2. When the power capacity is fixed, the cycle time has by far, the largest effect on capital cost with the price of vanadium having the next greatest effect. The cost of increasing the cycle time is a function of the cost of the vanadium; the longer the cycle time, the more vanadium electrolyte is necessary. This emphasizes the effect that the price of the vanadium electrolytes have on the capital costs. When the energy capacity is fixed, the power capacity and the cycle time have large and equal effects on the capital costs.

The sensitivity of the capital cost per kWh to various variables is presented below with accompanying graphs. In each case, the remaining variables are held constant so that the effects of the intended variables on the overall capital costs is illustrated more clearly.

The sensitivity of the capital cost per kilowatt-hour to the costs of the membrane can be seen in Figure 3-5. The sensitivity of the capital costs to the membrane costs does not change as the membrane costs increase, but the capital costs do rise. With the present day costs (used as the base case cost) the capital cost per kilowatt-hour is about \$391, which trends down to \$284 per kilowatt when the membrane price is \$40 per square meter, a DOE target for fuel cells.

The sensitivity of the capital costs per kilowatt-hour to the current density can be seen in Figure 3-6 for a family of curves representing different membrane costs. At lower current densities and higher membrane costs, the capital costs are quite sensitive to the current density.

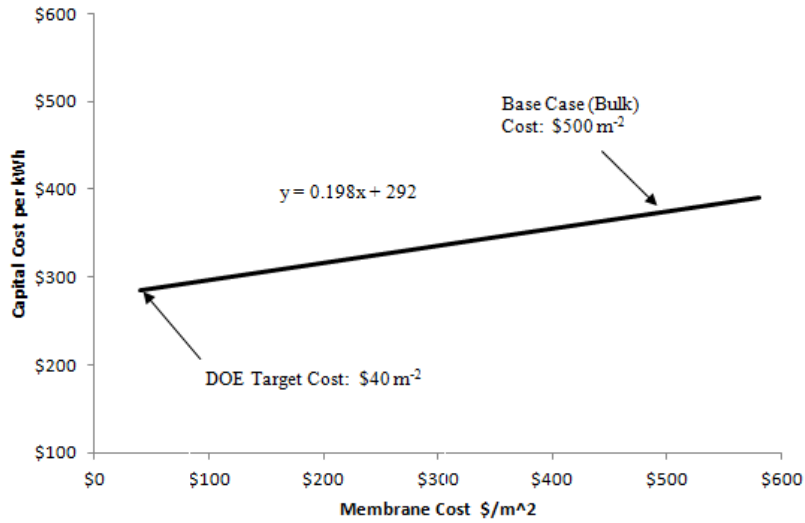

Figure 3-5. The effect of membrane cost on capital costs.

becomes less and less significant, until the majority of the overall cost is related to the costs for the components associated with the energy capacity.

The sensitivity of capital costs to current density for different electrode prices can be seen in Figure 3-7 for a family of curves representing different electrode prices. The increase in current density once again shows diminishing returns when approaching 100 mA/cm². The electrode price does not affect the sensitivity of the capital costs to the current density, as the lines show the same level of curvature for each electrode price.

The sensitivity of the capital costs per kWh to the cycle time can be seen in Figure 3-8. When the power capacity is constant at 1 MW, increasing the cycle time lowers the capital costs per kWh. The total capital costs will increase because of the larger tanks required and greater volume of vanadium electrolyte; however, the increase in the energy capacity of the VRB more than offsets this expense and lowers the capital costs per kWh.

The sensitivity of the capital cost per kWh to the cost of vanadium can be seen in the semi-log graph in Figure 3-9. The capital cost per kWh showed the greatest range when

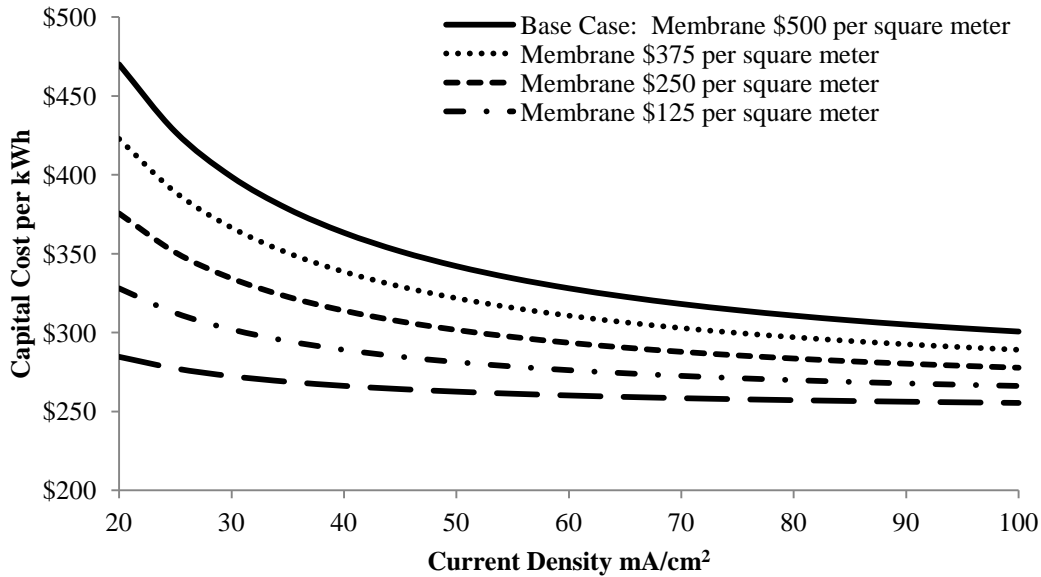

Figure 3-6. The effect of current density on capital costs.

increasing the cost of the vanadium from the cost of industrial grade vanadium at \$0.021 per gram to laboratory grade vanadium at \$2.10 a gram. There is a 100 fold increase in the cost of the vanadium electrolytes, increasing the capital costs per kilowatt-hour from around \$300 to around \$12,000. The differences in the prices can be explained by the purity of the vanadium, with the laboratory grade vanadium being of much higher purity. It is then important for a VRB to be able to use the lowest purity of vanadium as possible, so that the price of the vanadium can be kept at a minimum.

The increase in the capital costs per kilowatt-hour as the SOC limits are narrowed can be seen in Figure 3-10. As the SOC limits are narrowed by raising the lower limit toward a static upper limit of 0.80, the capital costs per kilowatt-hour increases. This increase becomes more dramatic the narrower the SOC range, in this case the higher value for the lower limit. This increase is due to the fact that as the lower limit of the SOC approaches the upper limit of 0.80, the difference in the volume of vanadium solution needed to store the energy at those limits

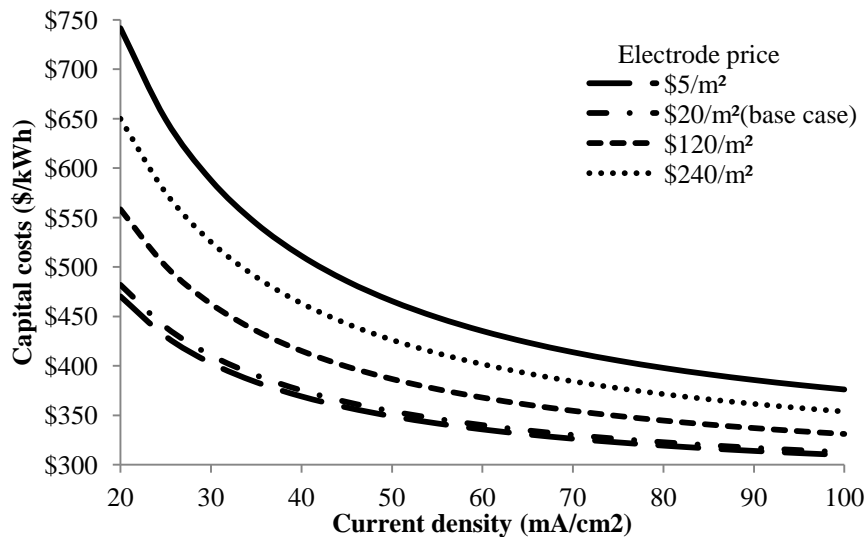

Figure 3-7. The effect of current density on capital costs for different electrode costs.

becomes greater. For example, when the lower SOC limit is raised from 0.2 to 0.225, the volume of vanadium electrolyte solution needed increases by 4.3%; however, when the SOC limit is raised from 0.3 to 0.325, the volume of vanadium electrolyte solution needed increases by 5.2%.

Figure 3-11 shows the capital costs per kilowatt-hour of a VRB when the energy capacity is held constant at 12 MWh, the power capacity is raised, and the cycle time is decreased. The higher power capacity translates into greater capital costs for the VRB. From the perspective of the VRB system design, the extending cycle time with the reduction of power capacity can potentially cut down the total capital cost when the power capacity is not the first consideration.

Conclusion

The relative sensitivity index for a fixed power capacity shows the importance of the costs of the vanadium to the overall capital costs. In addition, the capital costs per kilowatt-hour showed the greatest range when the vanadium costs were varied from the cost of industrial grade vanadium to the costs of laboratory grade vanadium. Note that a relatively large change in vanadium costs was considered in this analysis. Of course, the large change makes the cost of

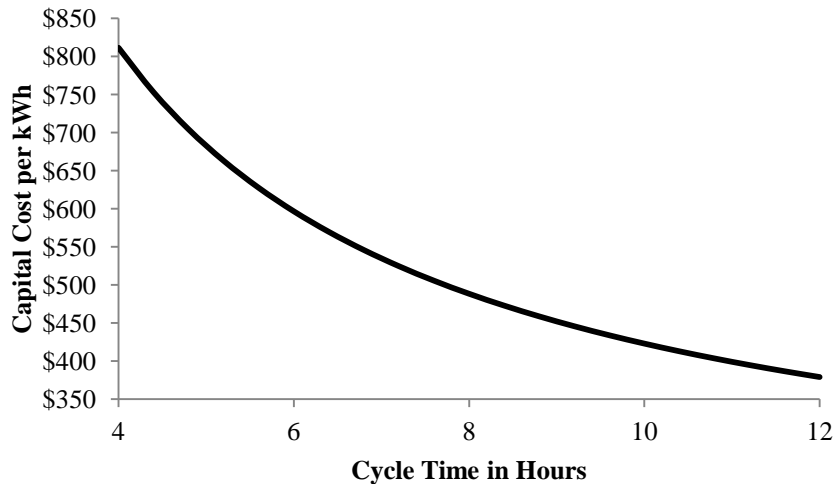

Figure 3-8. The Effect of Cycle Time on Capital Cost per Kilowatt-Hour for a 1 MW VRB.

vanadium appear to be an especially important parameter. The large change in vanadium cost was used because it was apparent that the use of high purity vanadium at current prices (approximately \$2,100 per kg) would be prohibitively expensive. It is clear that using vanadium costs near that of the lowest grade vanadium will be necessary to keep the capital costs of the VRB down. Vanadium costs like those for the laboratory grade vanadium would be almost 120 times greater than the ARPA-e goal. Better definition of vanadium purity requirements, less expensive sources of vanadium, and lower costs for reaching the required purity appear to be important needs for the VRB to meet or approach the ARPA-e goal.

When the energy capacity is held constant and the power capacity and cycle time are manipulated, the increased costs of the components related to the power capacity far out weigh the savings in the cost for the vanadium electrolyte and the tanks due to the lowered cycle time. This shows that there is a greater economic feasibility for VRB designs with a lower power capacity and longer cycle time for a set energy capacity.

The capital costs per kilowatt-hour are sensitive to the SOC limits, and the trade-off between the greater fluctuation in the power of the discharge and narrower SOC limits must be carefully weighed against this when designing a VRB. If it is necessary to have a narrower range

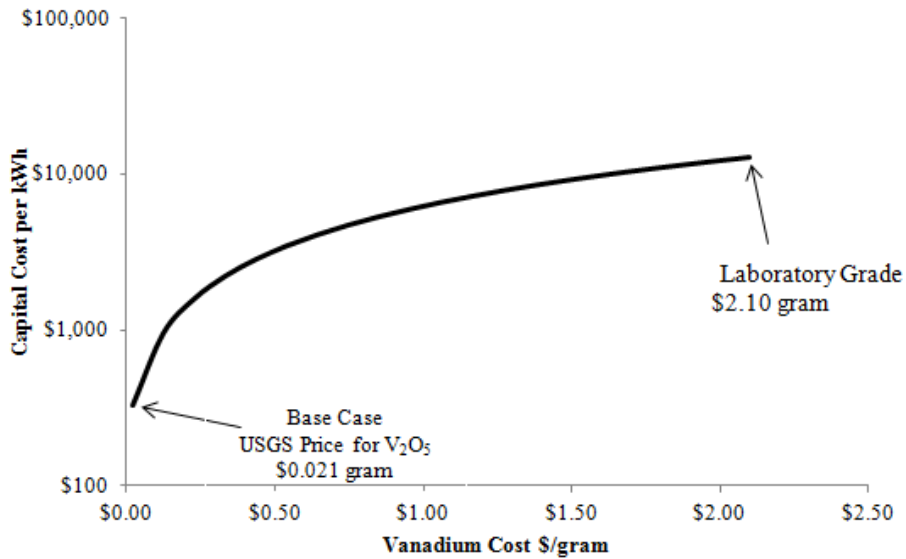

Figure 3-9. The Effect of Vanadium Electrolyte Cost on a VRB.

of power while discharging, the rise in the capital costs of the VRB will be steep; however, VRB uses where the power discharge is allowed a greater range will make the VRB far more affordable.

The increase in current density showed diminishing returns due to the costs of the components associated with the energy capacity. While the increase in the current density had a significant effect on the costs of the components associated with the power capacity, increasing the current density will have to be coupled with ways to decrease the costs of the components associated with the energy capacity to have a greater effect.

Since varying only one variable at a time was inadequate to reach the ARPA-e goal of \$100 per kWh for any of the variables, a more holistic approach must be taken in which multiple variables will be needed to reach the goal. Since some of the parameters reflect the different needs of individual electrical utility companies, it may be easier to meet or approach the cost goals for some applications than for others.

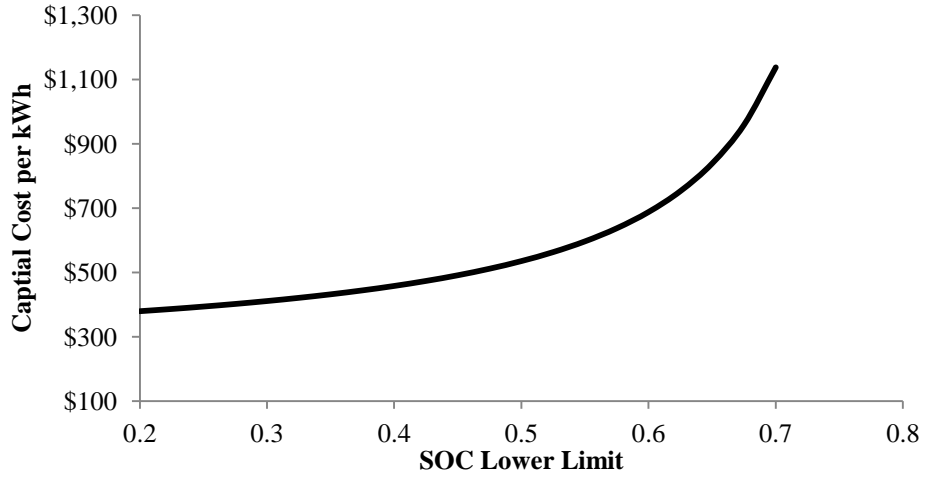

Figure 3-10. The Effect of SOC Limits on Capital Costs per Kilowatt-Hour.

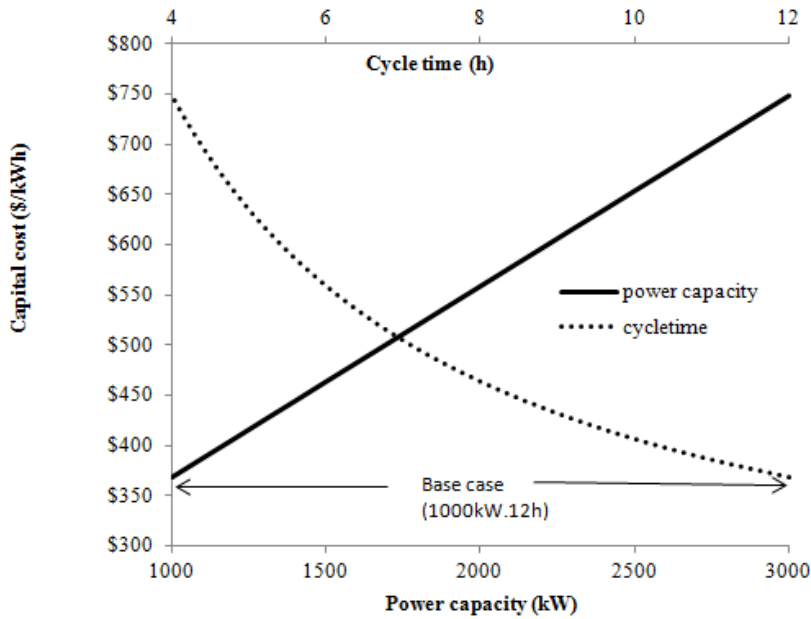

Figure 3-11. The Effect of Cycle Time and Power Capacity on Capital Costs per Kilowatt-Hour for a 12 MWh VRB.

Works Cited

1. EPRI_DOE Handbook of Energy Storage for Transmission and Distribution Applications, EPRI, Palo Alto, CA, and the U.S. Department of Energy, Washington, DC: 2003. 1001834.
2. Douglas, J.M. *AIChE J.*, **31**, 353 (1985).
3. *Vanadium Redox Flow Batteries: An In-Depth Analysis*. EPRI, Palo Alto, CA: 2007. 1014836
4. Cellstrom Home Page. <http://www.cellstrom.at/index.php?id=40&L=1> (accessed September 2011).
5. Moore M., Counce R., Watson J., Zawodzinski T., and Kamath H. A Step by Step Methodology for a Base Case Vanadium Redox-Flow Battery, submitted to *Chemical Engineering Education* (2011).
6. You, D; Zhang, H.; Chen, J. *Electrochem. Acta*, **54**, 6827 (2009).
7. U.S. Geological Survey. Mineral Industry Surveys. <http://minerals.usgs.gov/minerals> (accessed March, 2011).
8. *Vanadium Redox Flow Batteries: An In-Depth Analysis*. EPRI, Palo Alto, CA: 2007. 1014836
9. Ulrich, G.; Vasudevan, P. *Chemical Engineering Process Design and Economics: A Practical Guide*, pp 383-397, Process Publishing, Durham, (2004).
10. You, D; Zhang, H.; Chen, J. *Electrochem. Acta*, **54**, 6827 (2009).
11. Moore M., Counce R., Watson J., Zawodzinski T., and Kamath H. A Step by Step Methodology for a Base Case Vanadium Redox-Flow Battery, submitted to *Chemical Engineering Education* (2011).

CHAPTER 4: An Analysis of the Contributions of Current Density and Voltage Efficiency to the Capital Costs of an All Vanadium Redox-Flow Battery

Chapter 4 of this thesis is a slightly revised version of an article by the same name that has been submitted to the journal *The Electrochemical Society* by Mark Moore, Robert M. Counce, Jack S. Watson, Thomas A. Zawodzinski, Che-Nan Sun

My contribution to this paper included the development of the calculations and the authorship of the paper. Robert M. Counce and Jack S. Watson provided advice and editing support.

Introduction

The potential of the redox flow battery (RFB) for use in grid scale energy storage is well documented [1,2]. RFBs provide peak shaving, load leveling, energy reserve and grid stabilization capabilities to improve the performance of the utility grid and defer investments in additional generation capacity. [1] In addition, the energy generated by solar plants or wind farms can be stored in RFB's for discharge when the demand calls for it [2]. The Vanadium Redox Flow Battery [VRB] is one type of flow battery that has been developed for several applications and is a continuing subject of research and development.[2]

A schematic of a vanadium redox battery system is shown in Figure 4-1. The battery cells contain carbon felt electrodes and a cation exchange membrane which divides the cell into two compartments. One compartment is filled with a solution of V(II) and V(III) ions while the other compartment is filled with a solution of V(IV) and V(V) ions. The vanadium ions are dissolved in sulfuric acid, usually 1 to 5 mol/liter. The electrochemical reactions occurring at each electrode while the battery is being charged are given in equations 1 and 2. The reactions occurring while the battery is being discharged proceed in the opposite direction.[3]



In the paper of Zhang et al., the installed fixed capital cost (FCI) of the VRB operating at a current density of 40 mA/cm² was shown to be a strong function of the cost of the electrolyte (vanadium) and the cost of the ion exchange membrane.[4] The cost of the ion exchange membrane, such as Nafion, is expected to come down in coming years as the production rate increases due to increased use, largely in fuel cells. In this paper the effect of the VRB current density on their estimated FCI, costs of ion exchange membranes and vanadium is examined as a function of the current density. The cost of the ion exchange membrane in this paper is that

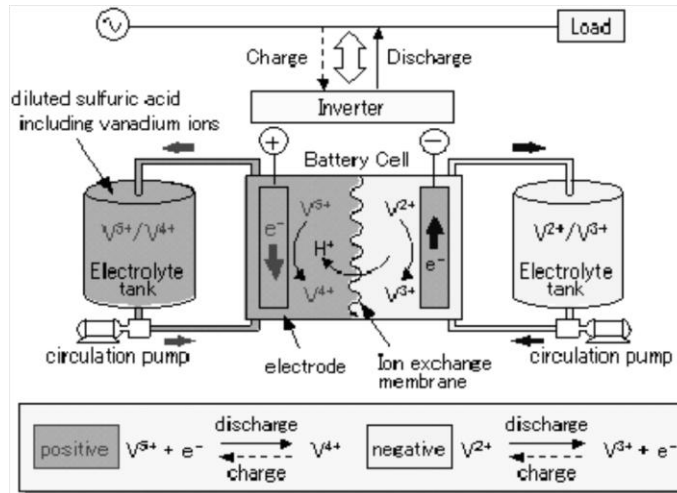

Figure 4-1. Schematic of a vanadium redox-flow battery.[1]

expected in the future at high production rates. The estimation model used in the current paper is taken from that presented by Moore et al.[3] The effect of current density on the VRB performance is from experimental data.

Engineering economic estimation is based on the expected cost of materials and equipment at a certain time. Over the period 2007 to 2011 the cost of vanadium has been as high as \$50.78/kg of V (\$/12.92/lb of V_2O_5); in the last reported period (2011) the average costs were \$26.72/kg of V (\$6.80/lb of V_2O_5).[5] These vanadium costs are for a technical grade; the cost of highly refined vanadium is much higher.

Jossen and Sauer's 2006 presentation at the First International Renewable Energy Storage Conference includes an estimate of the VRB fixed capital investment (FCI) of \$200/kWh for a 2 kW/30 kWh VRB [6] Their costs for the membrane was about \$35 per m^2 and their cost of V as V_2O_5 is about \$11.20/kg (\$5.08/lb) (\$20.00/kg of V). Both the costs of ion exchange membranes and vanadium appear to be reasonable estimates (especially if the membrane thickness is assumed to be 1 or 2 mills.)

The purchase cost of V is not indicated in economic papers of Schoenung and Eyer (2008), Schoenung (2011) or Oudalov et al. (2006).[8, 9,10] The purchase cost of vanadium in the EPRI (2007) work as V_2O_5 is about \$12.49/kg (7.00/lb) (\$27.51/kg of V) in 2007; the future purchase cost as V_2O_5 is estimated at about \$8.03/kg (\$4.50/lb) (\$17.69/kg of V).[1] Moore et al. and Zhang estimated the purchase cost of V as V_2O_5 is about \$6.39/kg (\$11.41/lb) (\$21.13/kg of V). [3,4]

The purchase cost of a 1 mill thick Nafion membrane at large future production rates is projected by James et al. to be \$20.73/m² (\$16.24 – materials, \$4.48 – labor) in 2010 and \$22.29/m² (\$17.20 – materials and \$5.08 –labor) in 2015.[7] A 1-mill thick Nafion membrane is N211. A high production rate purchase cost for a thicker membrane such as N117 (7 mill thickness) may be extrapolated from the numbers of James et al. to \$118.23 to \$145.11/m² (2010) or \$125.48 to \$155.96/m² (2015) (the high and low values being related to how the labor costs are scaled). [7]

The purchase cost of membranes is not indicated in papers of Schoenung and Eyer (2008), Schoenung (2011) or Oudalov et al. (2006). The purchase cost of membranes in the EPRI (2007) work is based on 1 to 2 mill thick Nafion is \$125 to \$350/m² for small quantity purchases and \$25 to \$65 for large quantity purchases in 2007.[1] Moore et al. and Zhang estimated a purchase cost of \$500/m² for Nafion N 117 (7 mill thick) for large-scale purchases in 2012.[3,4]

There are three different categories of FCI in energy storage – cost that scale proportional to power capacity, costs that scale proportional to energy capacity and fixed costs.[3] Expressed in equation form,

$$FCI = (\text{Power Capacity} \times \text{Scaled Capacity Costs})$$

$$+ (\text{Energy Capacity} \times \text{Scaled Energy Capacity Costs} + \text{Fixed Costs}) \quad [3]$$

or

$$FCI = x * (\$/kW) + y * (\$/kWh) + z \quad [4]$$

where x, y and z corresponded to the analogous equation above. For example the membrane stacks relate to power capacity (kW) and the quantity of electrolyte relates to energy capacity (kWh). The above FCI is approximately that of a fully installed and operable facility and does not include costs for working capital, contingencies, fees or auxiliary equipment.

Several publications have presented the FCI associated with a VRB, many of which give the total costs of a VRB per kilowatt and kilowatt-hour and are listed in Table 4-1.[1,8,9,10]. EPRI's thorough analysis gives both the purchase costs of the components used in manufacturing a VRB, overall costs per kilowatt and kilowatt-hour, as well as other important cost considerations.

An alternative to the above FCI estimation, based on the purchase costs of the major equipment items, was used by Moore et al. [3]; this method is used in this paper to examine the relationship between current density, voltage efficiency, and various costs related to VRBs. This approach is believed to provide a more systematic view of the relation between overall costs and the cost of different components under a range of operating conditions. The current density is a measure of the current capacity of the VRB per area of the cell electrode and for the analysis here, per the approximate cell membrane area. Increasing the current density has the effect of providing equivalent current, and therefore power, with a smaller cell stack. Unfortunately, increasing the current density lowers the voltage efficiency. The voltage efficiency has a strong affect on the cost associated with the VRB. As the voltage efficiency decreases, the number of cells of the (constant power) stack must increase in order to compensate for the lost power, increasing the costs of the cell stacks. With the increase in the size of the cell stacks comes a greater demand for vanadium electrolyte, increasing the total electrolyte capacity of the battery.

Table 4-1. Parameters for Fixed Capital Investment Estimates

Source	Energy Related Cost	Power Related Cost	Balance of Plant Cost
Schoenung and Eyer, 2008	\$350 per kWh	\$175 per kW	\$30 per kW
Schoenung, 2011	\$600 per kWh	\$400 per kW	
Oudalov et al, 2006	\$258-\$2,322 per kWh		
EPRI, 2007(2007 dollars)	\$300 per kWh	\$2,300 per kW	\$250,000
EPRI, 2007 (2013 dollars)	\$210 per kWh	\$1250 per kW	\$280,00

This balance between the voltage efficiency and the current density is crucial to determining the size, and therefore the FCI, of the VRB. Understanding the relationship between the voltage efficiency, current density, and FCI provides design parameters for a rudimentary design before the more exhaustive process begins.

Methodology

The methodology used to calculate the manufacturing costs for a VRB, taken from Moore et al.[3], has a number of assumptions, including:

- The costs of the cell stacks are based on the approximate membrane area (more exactly the electrode area) [3]
- The purchase costs of vanadium are based on prices for industrial (technical) grade vanadium set by the USGS [5]
- The power rating of the battery is based on the electrical potential at 50% state of charge (SOC)[1]

- The current efficiency is approaching 1 at the open circuit voltage.

In this costing method, the total electrode area (approximate membrane area) needed to meet the VRB's power capacity is calculated from equations 5, 6, and 7 [3]:

$$I_S = CD \times A_{Cell} \quad [5]$$

$$N_C = \frac{P}{I_S \times E_0 \times N_S \times \xi_V} \quad [6]$$

$$A_{Total} = N_C \times N_S \times A_{Cell} \quad [7]$$

where I_S is the current per cell, CD is the current density, A_{Cell} is the electrode area of one cell, N_C is the number of cells in one stack, P is the power rating of the battery, E_0 is the open circuit voltage of the cell, N_S is the number of stacks in the battery, and ξ_V is the voltage efficiency for charging or discharging. Combining the equations and canceling terms gives equation 8:

$$A_{Total} = \frac{P}{CD \times A_{Cell} \times E_0 \times N_S \times \xi_V} \times N_S \times A_{Cell}$$

$$A_{Total} = \frac{P}{CD \times E_0 \times \xi_V} \quad [8]$$

The purchase cost of the cell stacks is determined by the total electrode area, so the cost of the cell stacks are proportional the to the total electrode area, giving equation 9.

$$Purchase\ Cost\ of\ Cell\ Stacks \propto \frac{P}{CD \times E_0 \times \xi_V} \quad [9]$$

The driving factors for changes in the cost of cell stacks are power, current density, open circuit voltage and voltage efficiency. If the current density is increased while the power of the battery and the open circuit voltage are unchanged then equation 9 can be written as:

$$Purchase\ Cost\ of\ Cell\ Stacks \propto \frac{1}{CD \times \xi_V} \quad [10]$$

Equation 10 shows that for a VRB of a constant power capacity, the costs of the cell stacks is inversely proportional to the product of the current density and the efficiency.

The mass of the vanadium electrolyte needed for a VRB, and thus the estimated purchase cost of the electrolyte, can be found by calculating the number of electrons oxidized by the VRB during the entire charge or discharge process. Since the oxidation or reduction of vanadium ions involves one electron per mole, the moles of electrons oxidized will equal the moles of vanadium electrolyte that are oxidized. The calculation of moles of vanadium oxidized is shown with equation 11.

$$M_V = \frac{I_S}{F} \times t \times N_C \times N_S \quad [11]$$

Where M_V is the minimum number of moles of vanadium needed for the anolyte or catholyte, F is Faraday's constant, and t is the total time for a charge or discharge cycle (it has been assumed that the charge and discharge times are equal). Combining equation 11 with equation 6 and canceling like terms gives equation 12.

$$M_V = \frac{I_S}{F} \times t \times \frac{P}{I_S \times E_0 \times N_S \times \xi_V} \times N_S$$

$$M_V = \frac{t \times P}{F \times E_0 \times \xi_V} \quad [12]$$

Since the mass of the vanadium electrolyte needed largely determines the purchase cost of the electrolyte, equation 12 can be written as:

$$\text{Purchase Cost of Vanadium Electrolyte} \propto \frac{t \times P}{F \times E_0 \times \xi_V} \quad [13]$$

The time of the charge or discharge and the power are design parameters, and Faraday's number is a universal constant, leaving only the efficiency to change as the current density increases. If the current density is changed while the design parameters of the battery are held constant, the

cost of the vanadium electrolyte is inversely proportional to the product of the open circuit voltage and the efficiency. The efficiency in this case is defined as:

$$\xi_V \equiv \frac{E_{CD}}{E_0}$$

Where E_{CD} is the electrical potential at a defined current density. Equation 13 can then be written as:

$$\text{Purchase Cost of Vanadium Electrolyte} \propto \frac{E_0}{E_{CD}} \quad [14]$$

Results

The laboratory data shown in Figure 4-2 was used to calculate the voltage efficiencies at current densities between 0 and 2600 mA/cm². [11] Electrical potential at a current density of 0 mA/cm² represents the open circuit voltage, which in this case is 1.64 volts. To get the voltage efficiency for charging or discharging at any current density the potential at that current density is divided by the open circuit voltage.

With the voltage efficiencies associated with current density, the capital costs for VRB's at a range of current densities from 50 mA/cm², to 2500 mA/cm² were calculated using the method described by Moore et al. and the design variables listed in Table 4- 2.[3] Figure 4-3 shows the capital costs per kWh associated with the current density of the electrodes. After an initial drop off at very low current densities the rate of the increase in FCI is approximately steady until reaching about 2000 mA/cm², where it begins to escalate dramatically. Figure 4-3 shows the ideal range of current densities to design the battery in order to minimize the capital costs. The design variables for the estimate of the FCI are in Table 4-3. If the FCI of the VRB's are approximated as the costs of the stacks and the costs of the vanadium electrolyte (where the majority of the capital

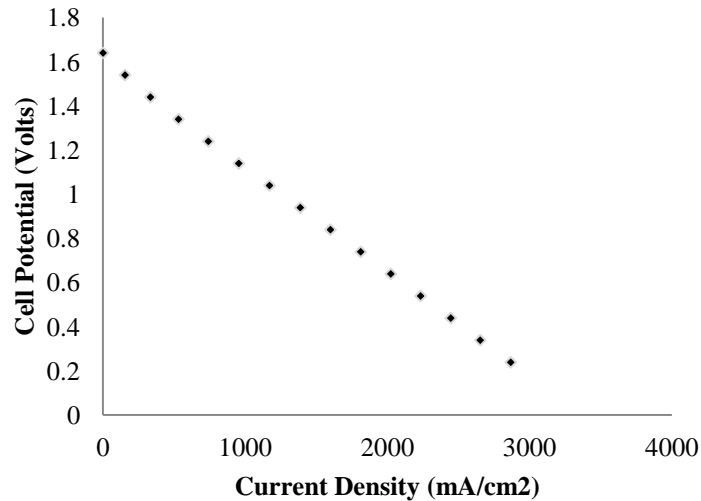

Figure 4-2. Cell Potential vs Current Density for a Laboratory VRB (ion exchange membrane = Nafion N 211; temperature = 30 C; and V and H₂SO₄ concentration are 1.7 and 3.3 mol/L.

costs are), equations 10 and 14 can also be used to approximate the ideal range of current densities for the VRB design.

Figure 4-4 shows the purchase costs per kWh of the cell stacks associated with the current density of the cell membranes (electrodes), which can be compared with a plot of Equation 10 in Figure 4-5. Membrane costs of \$25, \$75, and \$127 per square meter were used to illustrate that the shape of the curve is not affected by the cost of the membrane. In all other FCI calculations the membrane cost used was \$25 per square meter. Since the majority of the purchase costs for the cells stacks are associated with the membrane [3], the trend is illustrated again in Figure 4-6 which shows the total membrane area required for the VRB vs the current density. By comparing the minimal FCI in Figure 4-4 to the total capital cost (FCI) of Figure 4-3, it may be noted that the cost of stacks (including membranes) has become only a small fraction of the FCI.

Figure 4-7 shows the purchase costs per kWh of the vanadium electrolyte associated with the current density of the electrodes, and Figure 4-8 shows the amount of vanadium electrolyte

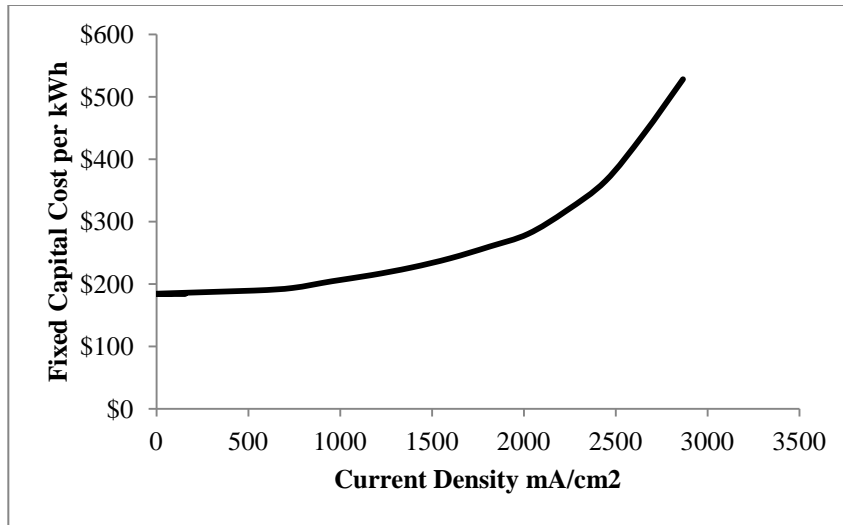

Figure 4-3. Fixed Capital Investment per kWh vs Current Density

required vs current density. Since the vanadium costs are on a per mass basis, these curves show a similar shape and trend, a slow increase in vanadium required/cost, until the current density approaches 2000 mA/cm² where the rise in vanadium required/cost becomes much more pronounced. The shape and trend of these curves appears to be well represented in Figure 4-9, a plot based on equation 14 at varying current density. The similarities between Figures 4-7, 4-8, and 4-9 suggest that the ideal range of current density for minimizing the costs of the vanadium can be easily predicted with equation 14.

Conclusion

The range of current densities used for battery operations continues to expand due to developments in research. [11] Considering that at conditions of former studies the majority of the FCI of the VRB are in the purchase costs of the cell stacks and vanadium,[3] it is useful to find the optimum range of the current density to minimize these costs. The purchase costs of the stacks and the vanadium, and how they are affected by changes in current density, were examined. Using new current density information,[11] a simple method of predicting the trends in the FCI of the cell stacks and vanadium over a range of current densities has been presented. This simplified perspective provides a quick and sound preliminary basis for the selection of a

Table 4-2 Design Variables for Estimate of VRB Fixed Capital Investment

Power Capacity	1000 kW
Charge Time	12 hr
Electrical Potential of 1 Cell	1.639 Volts
Number of Cell Stacks in Batter	20
Cost of Vanadium	25.13 \$/kg
Cost of Ion Exchange Membrane	25 \$/m ²
Cost of Current Collectors	51 \$/m ²
Cost of Carbon Felt	20 \$/m ²

specific operating condition (current density) for any intended application. In addition, this simplified perspective is valid regardless of the scale of the battery unless the scale should become large enough to affect the cost of vanadium or cell membranes. The shape of the curves showing the optimal range of current densities will be the same even if there should be significant changes in vanadium or membrane purchase costs. Perhaps the most important finding of this study is that at the conditions of higher current density, reduced membrane thickness and projected future membrane costs the dominant cost factor is only that of the electrolyte.

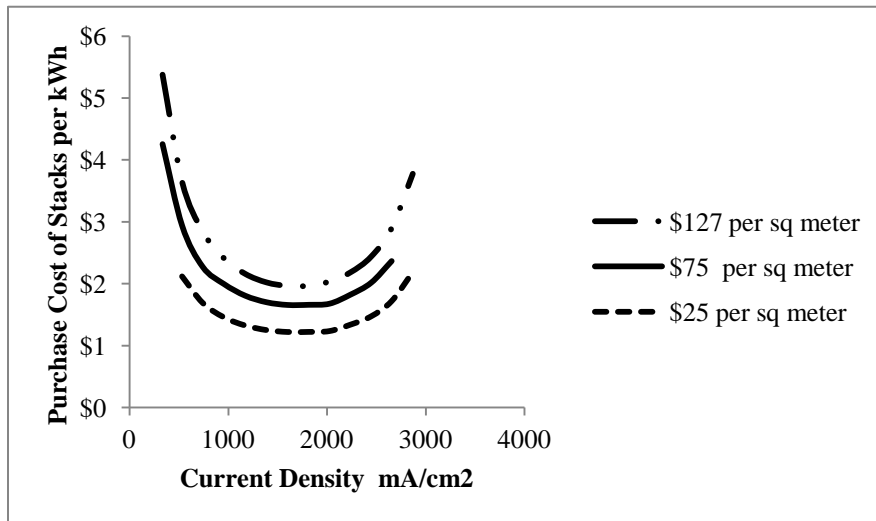

Figure 4-4. Purchase Cost of Stacks per kW/hr vs Current Density

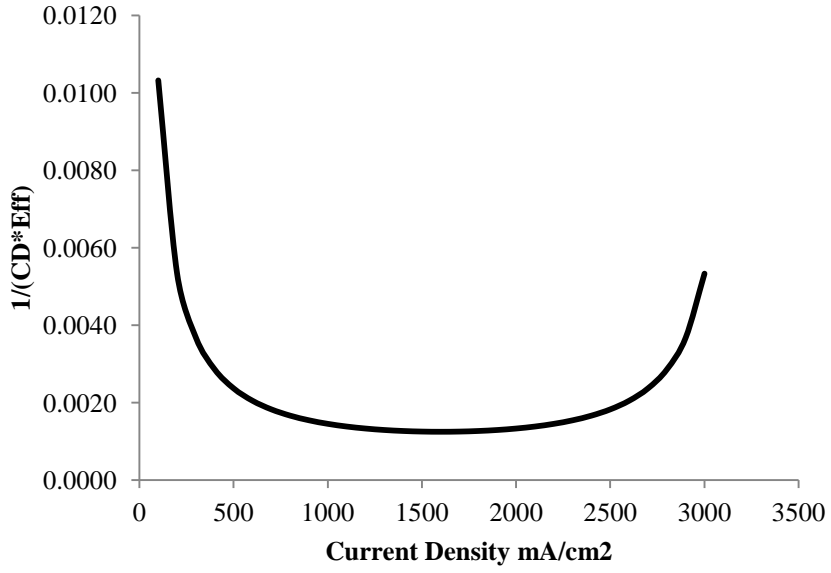

Figure 4-5. $1/(CD \cdot \xi_v)$ vs Current Density

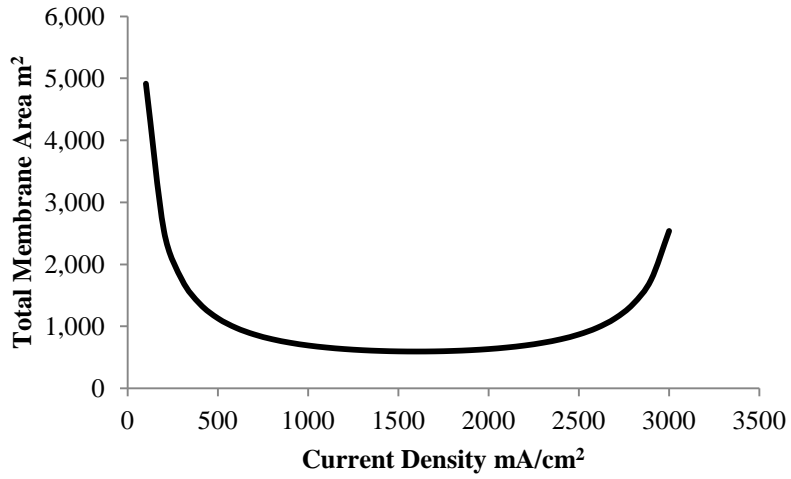

Figure 4-6. Total Membrane Area vs Current Density

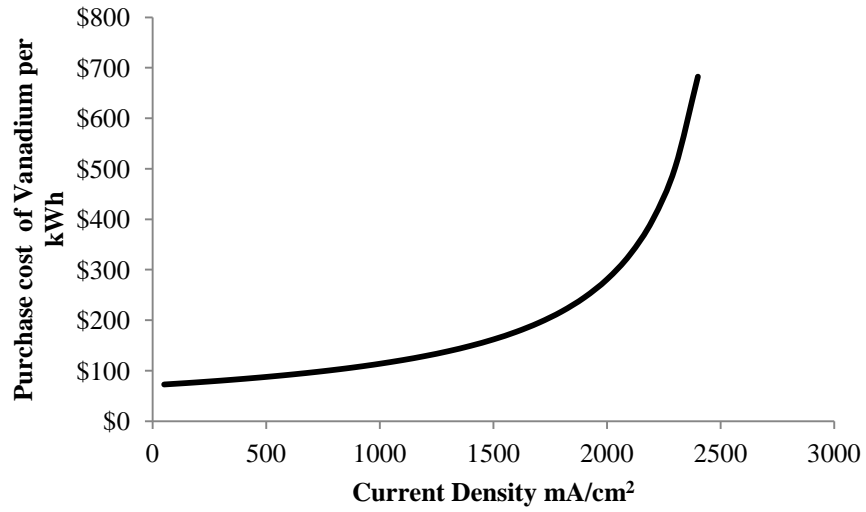

Figure 4-7. Purchase Cost of Vanadium per kWh vs Current Density

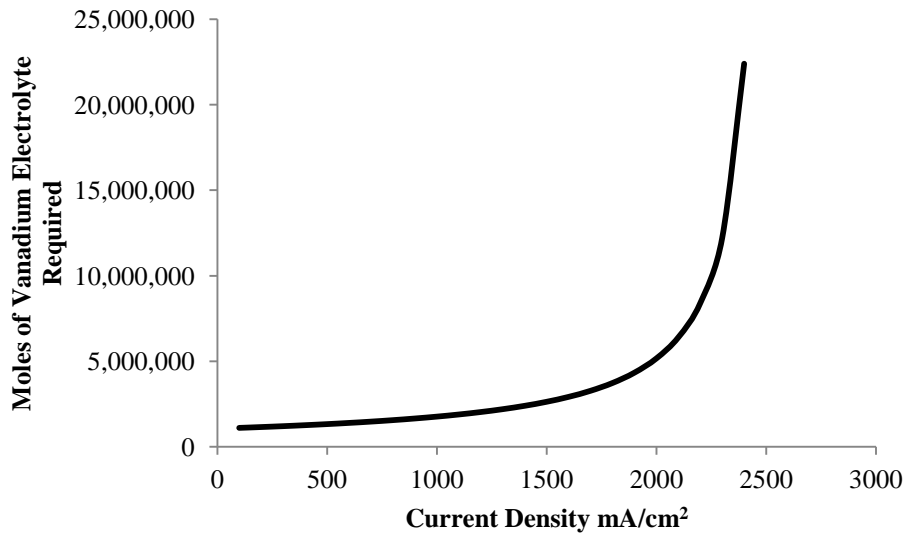

Figure 4-8. Moles of Vanadium Required vs Current Density

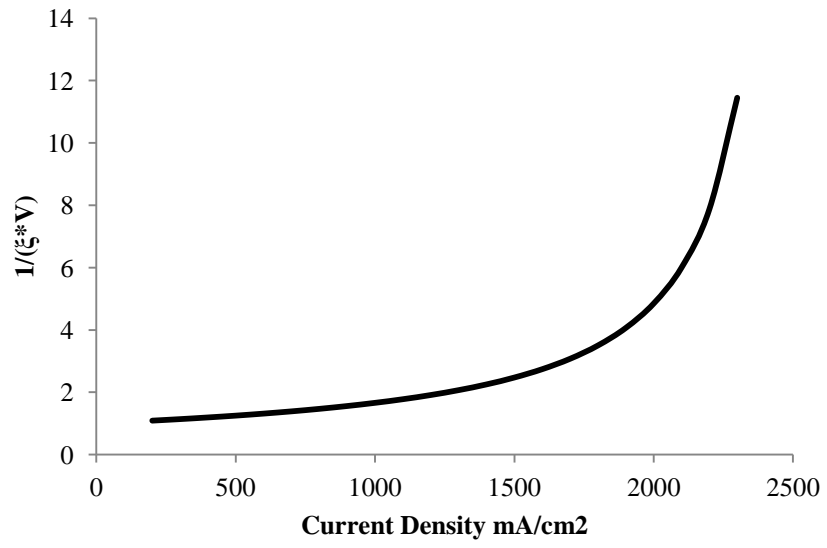

Figure 4-9. $1/(\xi \cdot V)$ vs Current Density

Works Cited

1. *Vanadium Redox Flow Batteries: An In-Depth Analysis*. EPRI, Palo Alto, CA, Report No. 1014836 (2007).
2. Kear, Garth, *Development of the all-vanadium redox flow battery for energy storage: a review of technological, financial and policy aspects*, *Int. J. Energy Res.*, (2011)
3. M. Moore, R. Counce, J. Watson, T. Zawodzinski, J. Kamath, "A Step-By-Step Design Methodology for a Base Case Vanadium Redox-Flow Battery," *CEE*, vol 46 number 4 (2012)
4. M. Zhang, M. Moore, J.S. Watson, T. A. Zawodzinski, R. Counce, "Capital Cost Sensitivity Analysis of an All-Vanadium Redox-Flow Battery," *J. Electrochem. Soc.*, vol 159 issue B (2012)
5. USGS, Minerals Information. <http://minerals.usgs.gov/minerals> (2013)
6. Jossen, D. Sauer, *Advances in Redox-Flow Batteries*, First International Renewable Energy Storage Conference, Gelsenkirchen Germany (2006)
7. James, B.D., J.A. Kalinoski and K.N. Baum, *Mass Production Cost Estimation for Direct H₂ PEM Fuel Cell Systems for Automotive Applications: 2010 Update*, Directed Technologies, Arlington, VA (2010)
8. Schoenung, S. and J. Eyer, *Benefit/Cost Framework for Evaluating Modular Energy Storage*, Sandia National Laboratories, Albuquerque, NM: SAND2008-0978 (2008)
9. Schoenung, S., *Energy Storage Systems Cost Update*, Sandia National Laboratories, Albuquerque, NM, SAND2011-2730 (2011)
10. Oudalov, A.; Chartouni, D.; Ohler, C.; Linhofer, G.; , "Value Analysis of Battery Energy Storage Applications in Power Systems," *Power Systems Conference and Exposition, 2006. PSCE '06. 2006 IEEE PES*, vol., no., pp.2206-2211, (Oct. 29 2006-Nov. 1 2006)
11. Che-Nan Sun, M. Mench and T. A. Zawodzinski, "Comparing Limits of Performance in Aqueous and Non-aqueous Redox Flow Batteries," manuscript in preparation.

CHAPTER 5: Conclusions

Conclusions

A step by step process for the design of a base case VRB has been outlined in Chapter 2. This process includes a capital cost analysis at every step to assess the potential for the profitability of the design. The relative sensitivity index for a fixed power capacity in Chapter 3 also shows the importance of the costs of the vanadium to the overall capital costs. Chapter 4 presents a simple method of predicting the trends in the costs of the cell stacks and vanadium over a range of current densities. This simplified perspective provides a quick and sound preliminary basis for the selection of the current density of the electrodes.

The wide scale adoption of the VRB, like any other chemical process, is dependent on the costs of construction as well as potential profitability. Together, Chapters 2, 3, and 4 provide a focus that could make the VRB more affordable. The costs of the permeable membranes can be lowered by increasing the current density of the half-cells, which decreases the overall size of the stacks. This, however, provides diminishing returns because of the increasing costs required for the vanadium electrolyte. The costs of the permeable membranes will go down if they can be manufactured on a larger scale, which will require a commitment to the manufacturing of a large number of flow batteries and fuel cells. The largest barrier to scale up in the use of VRB is the costs of the vanadium electrolyte. Finding ways to reduce the costs of the vanadium electrolyte would reduce the capital costs of the VRB and provide for a greater profitability.

VITA

Mark Alan Moore was born in Nashville, TN on May 18, 1972. He graduated from Oak Ridge High School in Oak Ridge, TN in 1990. From there, he attended the University of Tennessee, Knoxville majoring in Logistics and Transportation. He received his Bachelor's of Science degree in Logistics and Transportation in 1994. He returned to the University of Tennessee in 2009 to study Chemical and Biomolecular Engineering, receiving his Bachelor's of Science degree in May 2011. He began a Master's of Science in Chemical and Biomolecular Engineering in January 2012, with the expected graduation date of May 2013.