

Subject: Honors Project
To: mblackwe@utk.edu

E. Michael Blackwell,
2002

May 11,

Andrew James, a senior in Nuclear Engineering completed his honors design project examining the shielding design of a full body profiler for a Positron Emission Tomography (PET) scanner. The project report and presentation were of high quality and represent good professional engineering practice. Mr. James has completed the project to my satisfaction.

Faculty Mentor,

Arthur E. Ruggles
Nuclear Engineering.

Dosimetric Analysis of Prototype
P39 PET Scanner

Submitted by
Andrew R. James

Co-Authors:
Jason Curtis
Jarrod Edwards
Trey Johansen
Martin Williamson
Allan Wollaber

May 10, 2002

Faculty Advisor
Dr. A.E. Ruggles

Nuclear Engineering Department
The University of Tennessee

Acknowledgements

The Senior Design class would like to thank our faculty advisor Dr. A Ruggles for his time and guidance in our design project. We would like to express our thanks to Ken Baker of CTI Inc. for providing us with this project and its pertinent information. We also extend our gratitude to Dr. R. Pevey and Dr. F. Goldmeyer for their assistance in using MCNP. Dr. Carrol Bingham assisted with the source characterization. Additionally, we would like to thank Dr. W. Thompson and of UT Medical Center for his time and input regarding regulations and current PET technology. Kathryn M. Hunter, chief PET technologist, assisted us in obtaining pictures of a current machine. Finally, we would like to express our gratitude to the American Nuclear Society for sponsoring the student design competition.

Abstract

Positron emission tomography (PET) is a medical scanning technology having many uses, the primary one being cancer detection. PET scanners use positron-emitting radioisotopes that the body can metabolize. As the body metabolizes the isotopes, associated chemical changes show organ function. The ability to track organ function differs greatly from other imaging technologies that only show internal anatomy. Further advances in PET technology may enhance the quality of life by providing earlier and more accurate cancer detection than what is currently available.

With the help of CTI, Inc., a group of Nuclear Engineering students at the University of Tennessee worked to study the effects of altering PET scanner parameters. The group investigated using two different kinds of sources and shielding. The sources used were ^{22}Na and ^{68}Ge , and the different shielding materials were lead and tungsten. Dose rate maps are provided to determine the associated dose rates for the various parameters.

In accomplishing these objectives, several meetings took place between the students and CTI to determine what work would be needed. Students took a tour of the CTI facilities and also went to the University of Tennessee Medical Center to see a working PET scanner. During the visit to the UT Medical Center, the group acquired information about typical PET scanners, such as dimensions, radioactive sources, shielding materials, and other PET scanner materials. The students then modeled this information using a continuous energy and angle particle-transport code known as Monte Carlo N Particle (MCNP). Additionally, the students used Microsoft Excel to perform hand calculations and verify the accuracy of the MCNP code. To make comparisons with federal dose limit guidelines, a hypothetical technician and a patient-source were created, and design decisions were made based on this comparison.

For all cases, estimated annual dose does not exceed regulatory limits in 10 CFR 20.1201. For the purposes of minimizing dose rates, results establish that CTI should choose Tungsten as an attenuator and Germanium as the source. Results also show that if the Germanium source is chosen, it does not make very much difference which attenuator is used. The final recommendation, based on federal dose limits and economic factors, is to use Sodium as the source and Tungsten as the attenuator.

Personal Contributions

This project was completed jointly as a Nuclear Engineering Senior Design Class project and as a University Honors Program senior project. The project team consisted of six people, officially. The scope of the project required the efforts of a number of students to be completed within one semester.

My contributions to this project include original scope outlining, information gathering, calculations, results analysis, and report writing. After the general project selection, we had to narrow down the scope to a feasible goal for the semester. Our entire group then met with a CTI liaison who answered questions regarding the goals of our work. Another information-gathering trip to the UT Medical Center provided more background data. I worked with one other group member to perform hand calculations that were used to validate the results from our computer model. Analyzing the results to adequately answer our design questions required the input of most of the group members, including myself. I was also involved in the final information gathering and the report writing itself. I was personally involved in most aspects of this project, with the exception being the Monte Carlo N Particle (MCNP) computer modeling work. I am not familiar with this code package, and my involvement was unnecessary given the expertise of several of the other team members.

Table of Contents

1.0	Introduction	1
1.1	Background	1
1.2	Objective	3
2.0	Industrial Partnership	4
3.0	Choosing MCNP	5
4.0	Materials	6
5.0	Building the MCNP Model	7
5.1	Researching the design	7
5.2	Modeling the room and scanner	7
5.3	Modeling the source assembly	9
5.4	Modeling the source	11
5.5	Assumptions made in modeling	11
6.0	Hand Calculations	13
6.1	Purpose	13
6.2	Description of Hand Calculation Model	13
6.3	Mechanics of Performing Hand Calculations	14
7.0	Approximated Annual Dose Calculation Method	16
8.0	Results	17
8.1	Hand Calculation Results	17
8.2	MCNP Results	21
8.2.1	Germanium Source	22
8.2.1.1	Germanium/Exposed Source	22
8.2.1.2	Germanium/Shielded Source	24
8.2.2	Sodium Source	26
8.2.2.1	Sodium/Exposed Source	26
8.2.2.2	Sodium/Shielded Source	28
8.3	Z-dependence	30
8.4	Approximated Annual Dose Calculations	32
9.0	Conclusions	34
10.0	Recommendations for Future Work	35
11.0	References	36

Appendices

Appendix A: Typical MCNP Input File.....	37
Appendix B.1: MCNP Output Data – Slab Man Included	45
Appendix B.2: MCNP Output Data – Slab Man Not Included	46
Appendix B.3: MCNP Output Standard Deviation Data – Slab Man Not Included.....	47
Appendix B.4: MCNP Output Standard Deviation Data – Slab Man Included.....	48
Appendix C: Positron’s Range.....	49
Appendix D: Hand Calculations	50
Appendix E: Lutetium-Holmium Comparison	51
Appendix F: C Program to Strip Output from MCNP.....	55
Appendix G: CTI Drawings.....	58
Appendix H: Materials Information.....	61

List of Tables

Table 1: Example Hand-Calculation Spreadsheet	15
Table 2: Hand validation of MCNP results.....	18
Table 3: Matlab plot characteristics	22

List of Figures

Figure 1: PET Scan and Positron Emission.....	2
Figure 2: X-Z View of MCNP Model.....	8
Figure 3: X-Y View of MCNP Model	9
Figure 4: Source Assembly X-Z Views	10
Figure 5: Side View of Source Assembly	10
Figure 6: Top View of Source Assembly	10
Figure 7: Diagram of the model used for hand calculations	14
Figure 8: Graphical depiction of validity of the MCNP results using hand calculations.	19
Figure 9: Detector Point Locations in X-Y Axis	19
Figure 10: X-Z View of Room with Detector Tallies.....	20
Figure 11: X-Y View of Room with Detector Tallies	21
Figure 12: Germanium/Exposed/Lead/5ft	22
Figure 13: Germanium/Exposed/Lead/2ft	23
Figure 14: Germanium/Exposed/Tungsten/5ft	23
Figure 15: Germanium/Exposed/Tungsten/2ft	24
Figure 16: Germanium/Shielded/Lead/5ft	24
Figure 17: Germanium/Shielded/Lead/2ft	25
Figure 18: Germanium/Shielded/Tungsten/5ft	25
Figure 19: Germanium/Shielded/Tungsten/2ft	26
Figure 20: Sodium/Exposed/Lead/5ft	26
Figure 21: Sodium/Exposed/Lead/2ft.....	27
Figure 22: Sodium/Exposed/Tungsten/5ft	27
Figure 23: Sodium/Exposed/Tungsten/2ft	28
Figure 24: Sodium/Shielded/Lead/5ft.....	28
Figure 25: Sodium/Shielded/Lead/2ft.....	29
Figure 26: Soidum/Shielded/Tungsten/5ft.....	29

Figure 27: Soidum/Shielded/Tungsten/2ft..... 30
Figure 28: Z-Dependence for Source Configuration 31
Figure 29: Estimated Annual Dose for One Technician..... 32
Figure 30: Estimated Annual Dose for One Technician, Static Sources 33

1.0 Introduction

1.1 Background

Positron emission tomography, or PET, is a non-invasive nuclear medical scanning tool that measures metabolic activity in cells through the use of positron emitting isotopes. Traditional techniques of observing disease in people center around detecting changes in anatomy as a result of the disease. PET is unique because it produces images, or body profiles, of the body's basic biochemistry. Because the changes in metabolic activity will appear before changes in anatomy, and because metabolic activity occurs in all cells, the PET scan provides physicians with a more accurate picture of the patient's condition much sooner than traditional methods. For example, in diseases such as Alzheimer's, where there is initially no gross structural abnormality, PET is able to identify a biochemical change in the patient's brain. The radioisotopes used for PET imaging are ingested or injected into the body as radiopharmaceuticals. Radiopharmaceuticals are designed to react chemically consistently with stable isotopes that the body regularly uses for metabolic activity; thus, the radioisotopes are distributed according to the body's biochemistry. The positrons emitted by the radiopharmaceutical annihilate within millimeters of their source, resulting in two directionally diametric 511 keV gammas, which are detected by LSO detectors rotating around the patient. Figure 1 shows an example of PET scan imaging as well as gamma formation via positron annihilation. The scanner then analyzes the data from the detectors to develop an image of the patient's biochemical activity. Additionally, PET reduces patient risk, improves patient outcome, and decreases overall healthcare costs to the patient by, on average, \$1154. Further advances in PET technologies will enhance human life by providing earlier and more accurate cancer detection than is currently available.

One of the primary differences between this new PET compared to older versions is that it is hexagonally shaped. Additionally, there are two source rods, each containing ten sources, along only one of the six edges. This arrangement differs from older models in that the older ones had three source rods evenly spaced in the circumference of the scanning machine. These machines also contained a continual ring of detectors, which is different from the panel approach of the P39.

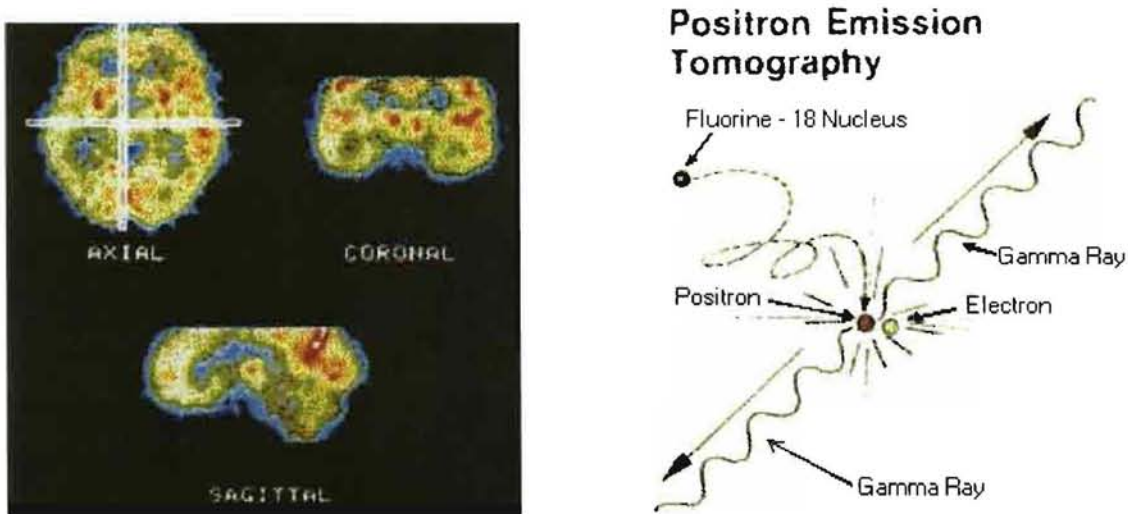

Figure 1: PET Scan and Positron Emission

(Source: <http://www.triumf.ca/welcome/petscan.html>)

A problem that exists with PET scanning technology is that some annihilation gammas will be attenuated within the body; thus, the scanner will not detect these gammas and they will not be factored into the created image. This phenomenon decreases the resolution of PET images by limiting the number of gamma rays that are used in forming the image and by partially invalidating the assumption that a lack of gamma detection indicates a lack of positron emission from that portion of the body. In order to minimize this detection error, a PET scanner utilizes another source of positron emission for the purpose of measuring gamma attenuation in the body. These sources, contained in a source assembly, operates by emitting a positron very close to a photon detector. The subsequent annihilation of the positron results in the emission of 2 511 keV photons, one of which is counted by the detector near the source. Another detector is placed on the other side of the patient from this source assembly and if the other photon created by the positron annihilation is not detected coincidentally with the first photon, it is assumed to have

been attenuated. Thus, by using this source assembly, the scanner can account for attenuation of photons by the body, and the resulting image is made more reliable. This source assembly is the basis for our group's work in P39 PET development.

1.2 Objective

The 2002 University of Tennessee Nuclear Engineering Senior Design Group is working in collaboration with CTI, Inc. to determine the optimal configuration of source and shielding material for the point source assembly of the P-39 PET scanner being developed by CTI. To this end, we study the effects of using Sodium-22 or Germanium-68 as the source, and tungsten or lead as the attenuator. Dose rate maps are developed corresponding to sixteen different configurations and detector setups. These configurations correspond to combinations of source, attenuator, exposed/unexposed, and two different heights in the room (2 ft and 5 ft). A theoretical technician is then considered for the purposes of illustrating the relationships between the dose rate calculations and annual dose received which are compared to NCRP dose limit recommendations. We, then, consider this information with the cost effectiveness of the various source and shielding combinations to arrive at our final conclusion for the optimal source assembly configuration.

To meet these objectives, a broad scope of activities must be performed. These activities include meeting and corresponding with CTI engineers to obtain operational and material information, as well as dimensions, for the developmental P-39 scanner. The group tours the UT Medical Center Hospital in order to observe a working PET scanner and obtain information regarding operational dose limits, typical room dimensions where a PET scanner is located, and further dimensions of a typical PET scanner that could not be provided by CTI. The group then models this information using MCNP code, and uses this model to calculate the dose rates delivered to patients and personnel. Hand calculations are performed in order to validate the accuracy of the MCNP code. Once MCNP results are validated, they are used to calculate a conservative approximate annual dose received by a technician and are compared with NCRP guidelines. Then, this information is considered with economical data to determine the final optimal source and shielding configuration.

2.0 Industrial Partnership

Our primary corporate partner in reaching our design goal is CTI, Inc. CTI, Inc., headquartered in Knoxville, Tennessee is the worldwide leader in PET products. The leading PET products that CTI markets are the ECAT tomograph, the RDS cyclotron, and the LSO detector. Worldwide, over 200 ECAT tomograph units are in place, as well as over 50 RDS units. Technological advances generated by CTI employees include “custom integrated circuit electronics including patented analog VLSI chip, BGO block detectors with patented light guide design and isotropic resolution, patented point source attenuation measurement system, new scintillation detector materials such as LSO and photodetectors based on avalanche and p-i-n photodiodes, cyclotron self-shielded with unique material, cyclotron target carousels that provide up to sixteen targets with only two beam ports, proprietary time-dependent particle tracking simulation system, (and) patented deep-valley magnet design with single-sheet coil using integrated circuit board technology.”

The idea for this project was brought to our attention by CTI, Inc. Following the development of a project proposal and the subsequent acceptance thereof, contact began between our group and Jim Baker of CTI. The group then began collaborating with CTI to determine specific information about the developmental scanner. CTI sent drawings to aid in the design of the shielding and other relevant materials around the twenty sources of the P39 scanner, and allowed us to see a prototype of the P-39 scanner.

Secondary industrial partnership includes assistance from the UT Medical Center Hospital. Dr. Wayne Thompson came and spoke with us about dose limits and hospital room configurations regarding the PET scanner. Then, he and Kathryn M. Hunter took our group on a tour of the UT Medical Center facilities to allow us to take physical measurements and observe a PET scanner in operation.

3.0 Choosing MCNP

Calculating dose rates or fluxes at various positions around the PET scanner is a problem well suited for the Monte Carlo N-Particle computer code (MCNP). This code takes as inputs the PET geometries, materials, and the gamma source energies and distributions. Although this type of problem is similar to reactor core problems, MCNP never attempts to directly solve a Boltzmann-like equation. Rather, MCNP is a stochastic code in that one may describe the calculations it performs in a method analogous to the one Nature employs. By generating random numbers to choose parameters like particle direction and energy, MCNP follows a particle's life from birth to collision events to death. In the end the code will tally the effect of interest; here it is the gamma flux at several distributed detectors. The main problem inherent to a stochastic code such as this is in order to have accurate information; one must generate a large amount of random numbers or, in our case, particle life simulations. Naturally, the more particles the code follows, the more accurate the dose at a detector will be. Accuracy is described by the standard deviation of the answer, and the standard deviation should decrease as a function of $1/n^{0.5}$ where n is the number of particles. N frequently is greater than a million particles, and each code run may be on the order of days to obtain suitable results. Thus, the tradeoff of not having to numerically solve a complicated integro-differential equation is increased runtime. The geometry and material input to an MCNP model is made by creating cells from the proper allocation of surfaces and filling the cells with materials consistent with those of the physical system of interest.

4.0 Materials

Other guidelines used in the design of the shielding are the materials. CTI suggested examining the effects of using either tungsten or lead as shielding material to cover the sources when unexposed. Both materials have properties that suit well the purposes of shielding. Other material considerations were made regarding the materials in the machine itself, such as wiring, junction housing, electronics, scanning-machine frame, and so on. It was decided to neglect these additional materials as they would only contribute additional shielding to our problem, and neglecting them would allow for conservative calculations of dose in the examination room.

CTI suggested the use of either ^{22}Na or ^{68}Ge as the source in our scanner. The relevant data for each of these two sources is used in the computer model.

Holmium is used in the MCNP material composition in place of lutetium. Lutetium is not available in the MCNP material library. A supporting comparison of stopping powers for holmium and lutetium is attached in Appendix E.

Appendix H includes number densities and weight fractions for the materials used in the MCNP model.

5.0 Building the MCNP Model

5.1 Researching the design

Most of the data used in the MCNP model has been supplied by CTI. The group visit to CTI provided a general idea of the setup, size, and orientation of the P39 machine, while the material and dimensional data were included in detailed engineering drawings. The drawings provided the dimensions for the hexagonal gantry and the individual and total source assemblies. Personnel from CTI presented information concerning the detectors and radiation source type and strength to be used. Also provided was information about general room size.

A visit to the University of Tennessee Medical Center also yielded useful information. The team was able to observe a current model PET scanner in operation with the cover removed. This illustrated the motion of the sources during an actual scan, including when the sources are exposed during scanner operation. Room size was observed in addition to scanner orientation within the room. This visit provided the bases for several of the assumptions made in modeling the room and scanner. A typical MCNP input file is given in Appendix A.

5.2 Modeling the room and scanner

The minimum room dimensions for housing a P39 PET scanner were given by CTI to be 13 ft x 19 ft. The MCNP model is of a medium-size 15 ft x 20 ft room, since the results of this report are to be generally applicable. The walls, floor, and ceiling are all modeled as 30 in of high-density concrete, which according to Dr. Wayne Thompson of UTMC is the general design basis for PET room walls. The orientation of the scanner is halfway between the walls in both directions. The orientation of the hexagonal gantry is vertical, with its axis parallel to the floor.

Exact dimensions for the hexagonal array can be found in CTI engineering drawings attached to this report. The depth of the scanner from front to back was not included in the technical drawings, but is estimated to be 50.8 cm based on the prototype P39 at CTI and the length of the source rods. Five sides of the array are detectors, while the sixth side is the source assembly. The cross-sectional configuration is illustrated in a drawing attached to this report. The five “detector” sides each include two instrumentation boxes, based on the observed P39 prototype and information supplied by CTI. The contact surface between the first box and the hexagonal face is a 1.375 cm-thick slab of LSO to represent the detector panel. The first (inner)

box is composed of aluminum; the second is composed of 1020 stainless steel. The thickness of all these boxes is 0.3175 cm. These boxes house the detector electronics and wiring.

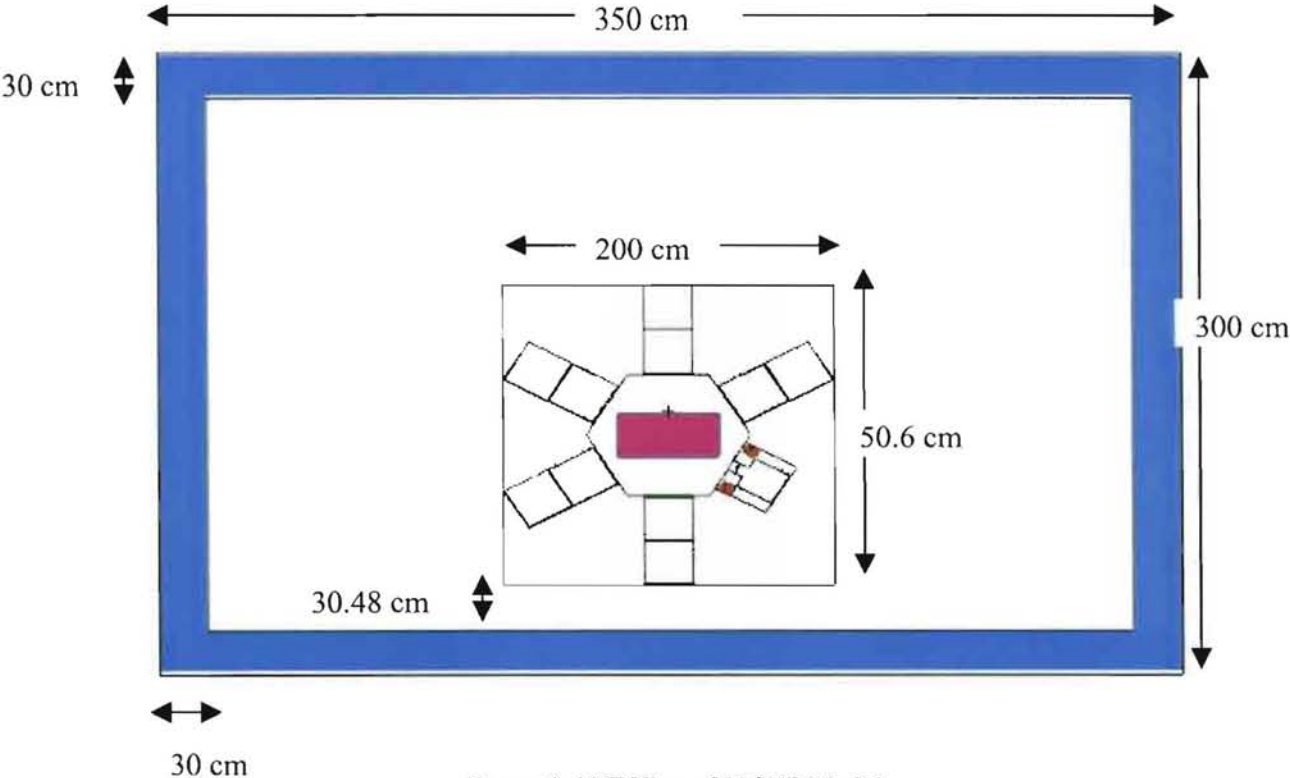

Figure 2: X-Z View of MCNP Model

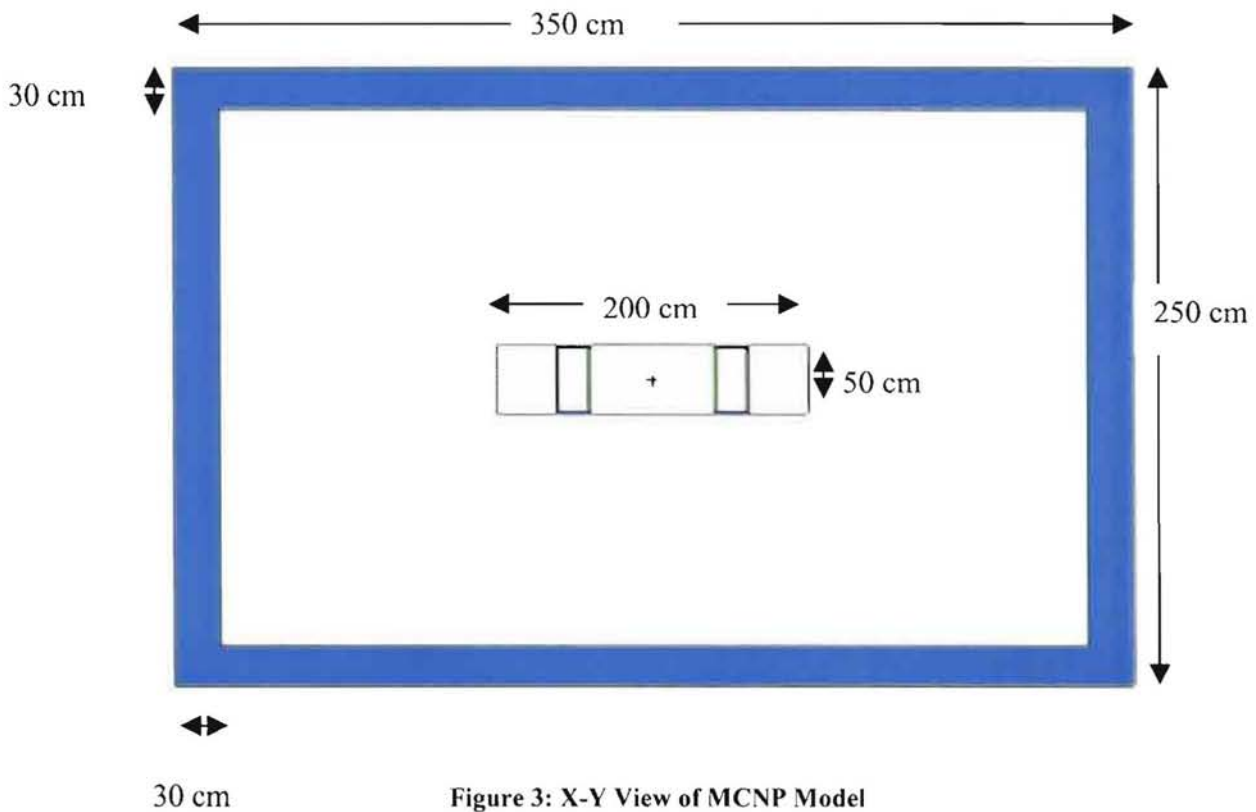

Figure 3: X-Y View of MCNP Model

5.3 Modeling the source assembly

The total assembly of twenty sources includes two rods, each composed of ten sub-assemblies housing single 1-mCi Ga sources. An engineering drawing of a sub-assembly is attached to this report. The sub-assemblies are in contact with one another, with 2 in of space between each of the ten sources in a rod. The two source rods are parallel to each other with 5 inches separating them. This assembly configuration is also illustrated in Figures 4-6. There is also an instrumentation box made of aluminum modeled around the source assembly to house electronics and wiring associated with the sources.

Since the scanner will be rotating about its axis during operation, the MCNP models have six possible orientations of the hexagonal scanner mechanism. These six configurations correspond to placement of the source assembly on each of the six faces of the hexagonal array. The remaining faces in each setup are again “detector” sides. This allows the scanner to be approximated as rotating, as it is during operation.

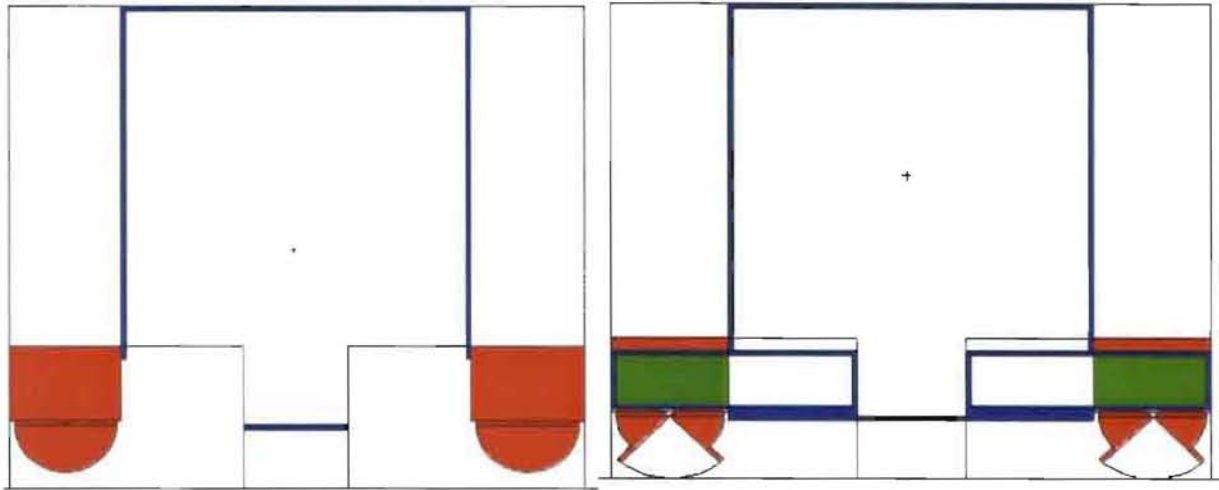

Figure 4: Source Assembly X-Z Views

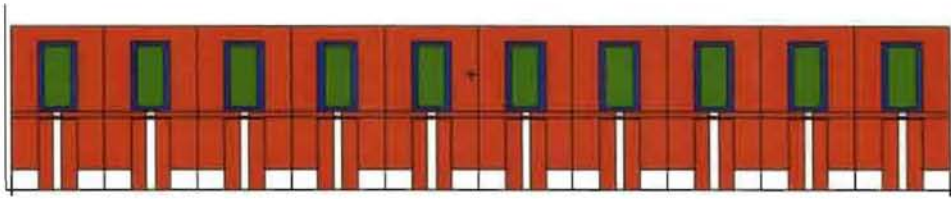

Figure 5: Side View of Source Assembly

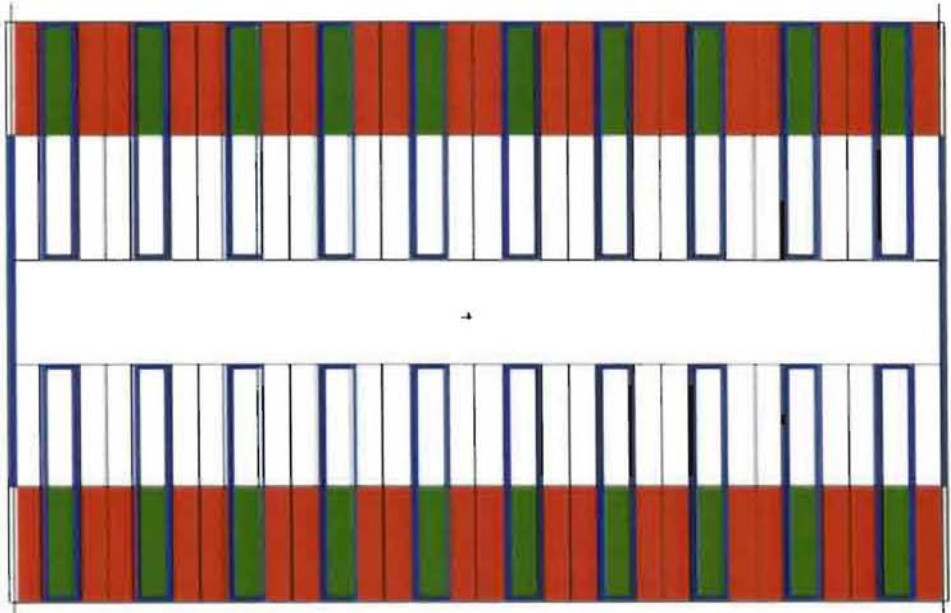

Figure 6: Top View of Source Assembly

5.4 Modeling the source

The source was modeled in MCNP using data from the *Table of Isotopes* and the online *Chart of the Nuclides*. The source includes x-ray, gamma, and beta particle decay energies from Germanium-68 to Gallium-68 to stable Zinc-68.

The decay of germanium to gallium results in the emission of an x-ray 46% of the time. These intensities, relative to one gallium nucleus being formed, are included in the source particle distribution. One gallium nucleus has an 11% chance of decaying by the emission of a gamma. The energies of these particles are included, with their respective percentages appropriately summing to 0.11. The remaining 0.89 particles are betas emitted with one of two energies. These particles may emit Bremsstrahlung radiation, which is accounted for in the source. Each beta particle (0.89 of one decay) is also double-counted as two 511 keV photons that must result from annihilation. For each Ge/Ga decay, there is a 0.03 probability that the resultant Zn-68 will emit an x-ray. This is also included in the source model.

5.5 Assumptions made in modeling

In creating the MCNP model, several assumptions were made for conservatism and convenience. These assumptions are listed as follows with their corresponding rationale:

- No electronics or wiring in the instrumentation boxes – Virtually impossible to model using MCNP, and do not contribute appreciably to gamma attenuation. It is conservative in calculating dose rate not to account for the attenuation from electronics.
- Bed and scanner casing not included – Due to their low cross-section materials, e.g. plastic, neither of these components contribute appreciably to the attenuation of gammas. As before, it is conservative not to include this small contribution to attenuation.
- Air is modeled as void – Model simplification without appreciable error in results. Also conservative in nature, so as to over predict dose.
- Lutetium in LSO modeled as holmium – Lutetium is not included as a material in MCNP. Holmium was found to have very similar properties to lutetium. Holmium stopping power is slightly lower than that of Lutetium, leading to conservative results. Data supporting this assumption are included in Appendix E.
- It is not necessary to model a patient as a radioactive source for this study, since changing the source intensity of the patient is a parameter outside the scope of the machine design.

A hypothetical patient and technician are added later for the purposes of comparison to the federal dose-limiting guidelines and making design judgments, but their parameters are not included or varied in the MCNP model. .

6.0 Hand Calculations

6.1 Purpose

Hand calculations are performed in order to provide a validation for the dose rates calculated from the MCNP cases. To provide this validation, maximum and minimum dose rates are calculated to provide boundaries between which a successful determination of the dose rates by MCNP should fall.

The equation $D(\vec{r}) = \frac{S_p R(E_o)}{4\pi r^2}$ establishes a logical maximum boundary for the dose rates because it assumes that particles are unattenuated between the source and the phantom. Thus, all particles traveling in the direction of the phantom will reach the phantom with their respective initial energies, thereby providing a maximum possible dose received by the phantom.

The equation $D^o(\vec{r}) = \frac{S_p R(E_o)}{4\pi r^2} e^{-\mu(E_o)r}$ serves to establish a logical minimum boundary for the MCNP result. In this equation, attenuation significantly limits the number of particles reaching the phantom without accounting for dose contribution by collided photons, thereby providing a minimum dose boundary for the MCNP result.

6.2 Description of Hand Calculation Model

The model developed for the hand calculations reasonably approximates the model in MCNP for validation by the establishment of reasonable maximum and minimum dose rate boundaries. A diagram of this model at the end of this description illustrates the dimensions and positions of the source assembly and phantom.

As in the MCNP model, 20 1mCi sources are modeled in 2 rows of 10 sources each. In order to simplify calculations, the rows are modeled in the same horizontal plane as the phantom with the phantom perpendicular to the rows of sources. This assumption is reasonable because the added distance perpendicular to the plane of the sources would have a negligible effect on dose rate. Other source dimensions are equivalent to the dimensions in the MCNP model. Initial particle energies and corresponding relative appearances, following the decay schemes in Section 4.4, correspond to the particle energies used in the MCNP model.

The phantom is modeled using response functions corresponding to the respective initial particle energies from the MCNP manual. The dose rate to the phantom is considered for hand calculations at specific points in order to validate the dose rates calculated by MCNP at the established point detectors, called tally points, in the code. The same response functions are used in the MCNP and hand calculations.

Lead and tungsten, which are used as the primary shielding for the point sources, are the only attenuating mediums considered in the hand calculations. The corresponding mass attenuation coefficients are found in Table C.6 of Reference 6. Attenuation by other materials included in MCNP and dose contribution by collided photon build up is excluded for the purposes of the hand calculations. Though not necessarily equivalent, the counteracting nature of the excluded attenuation and photon build up allows that they both be excluded in order to simplify the hand calculation model without significantly changing the resulting dose minimum. Also, the exclusion of collided photon contributions allows for the use of response functions that correspond to the initial photon energies since the final energy of uncollided photons will be the same as the initial energy.

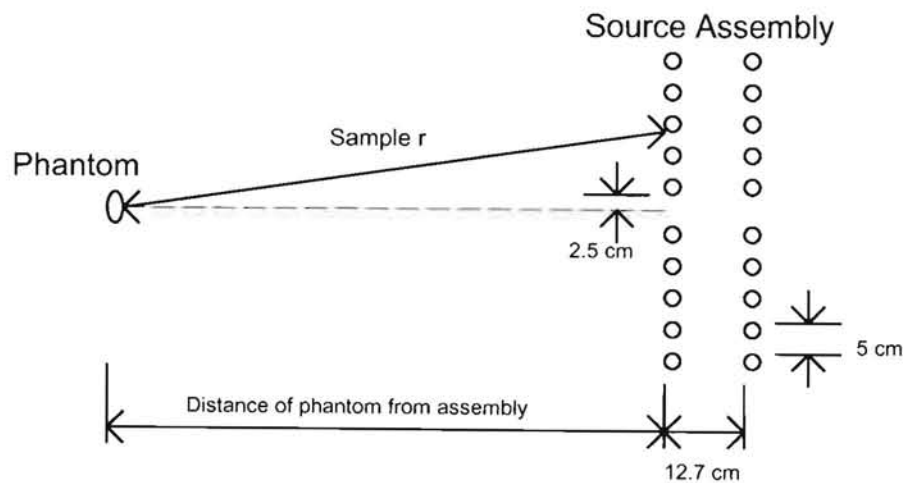

Figure 7: Diagram of the model used for hand calculations

6.3 Mechanics of Performing Hand Calculations

The actual calculation of maximum and minimum dose rates is performed using a spreadsheet in Microsoft Excel. The arrangement of the spreadsheet allows the distance of the phantom from the source assembly, thickness of the primary attenuating medium, and source strength are easily varied to study the effects of each of these factors on the dose rate boundaries.

The format of the spreadsheet correlates relative number of particles with each energy emitted with each source disintegration, response function, and attenuation factor, if applicable, to the respective particle energy. The relative number of particles at each energy emitted is multiplied by the source strength to find S_p in the respective equation. $R(E_o)$ is the response function for the respective photon energy, and r is the distance of each 1 mCi point source to the phantom. Due to the symmetry of the model, the doses of half of the point sources are calculated, and the final total is doubled to find the total dose rate. Finally, the attenuation factor is calculated by multiplying the material density by the previously determined respective mass attenuation factor.

The total dose rate for the specific maximum or minimum calculation is then determined by using the respective equation to create a matrix in which the doses to the phantom by photons of a particular energy at a particular distance from the phantom are calculated for each photon energy at each radius. An example of the spreadsheet format is shown below:

Photon Data	Radii of Sources			
	Radius 1	Radius 2	Radius 3	Radius 4
Data for Photon Energy 1	Dose for Energy 1, Radius 1	Dose for Energy 1, Radius 2	Dose for Energy 1, Radius 3	Dose for Energy 1, Radius 4
Data for Photon Energy 2	Dose for Energy 2, Radius 1	Dose for Energy 2, Radius 2	Dose for Energy 2, Radius 3	Dose for Energy 2, Radius 4
Data for Photon Energy 3	Dose for Energy 3, Radius 1	Dose for Energy 3, Radius 2	Dose for Energy 3, Radius 3	Dose for Energy 3, Radius 4
Data for Photon Energy 4	Dose for Energy 4, Radius 1	Dose for Energy 4, Radius 2	Dose for Energy 4, Radius 3	Dose for Energy 4, Radius 4

Table 1: Example Hand-Calculation Spreadsheet

The summation of these dose rates is the total dose rate to the phantom.

7.0 Approximated Annual Dose Calculation Method

Since design decisions must be made based on regulatory guidelines, it is necessary to create a hypothetical “technician” who could receive a maximum amount of dose during a given year. The regulatory guideline to meet is found in 10 CFR 20.1201, and states that no occupational worker should receive more than the total effective dose equivalent of 5 Rem/year. For these calculations, it is not accurate to leave out the dose received due to the radiopharmaceutical injected into the patient. Hence, a 10 mCi source of F-18 has been assumed in the center of the PET machine. The net effect of this is to add a dose rate of 1.5 mRem/hour at a distance of 1.5 meters, as stated on the P.E.TNet website. Since the average detector distance from the center is nearly 1.8 meters, it is conservative to simply add this dose rate to all the detector doses. The annual dose for the technician is then created by averaging all dose rates at the 5-foot detector level, which effectually places the technician at each detector location an equal amount of time. There will then be one dose rate for each MCNP input case. These dose rates are then split into two categories, one for the exposed cases and one for the shielded. For these calculations, it is assumed that the patient is only in the room when the source is exposed. Each of these cases is multiplied by 1000 hours, and the resultant shielded and exposed doses are summed, effectually placing the technician in the room for a full working year. These numbers are then averaged over the six different source locations on the PET scanner, which creates the effect of a spinning scanner. Design decisions are then made based on these doses.

8.0 Results

The results for the MCNP runs and the hand calculations are included below. First the validity of the results is discussed via the placement of upper and lower bounds using hand calculations. Next are the graphs, which are obtained from averaging the detector data over various sources to get an idea of the effects of the PET scanner in motion. Finally, the worst-case height dependence is presented and discussed.

A total of 64 different input decks were used which varied the source position, shielding material, source type, and the presence of a water-filled box in the center of the scanner that is typically used to approximate the dose and scattering due to a patient. The 32 runs that included this slab-man produced inadequate results in that the standard deviations were generally high and there were several minor problems with the input decks. The other 32 runs that do not include the slab-man model this area as void, and should be conservative from a shielding perspective. For each case, MCNP computes for 1220 minutes, or 24 hours, of computer time on 1.7 GHz IBM personal computers. 2 to 3 million particle histories were typical for each of these cases. This large amount of time is required for each case to attain acceptable standard deviations. Standard deviations for these runs are normally around 1%, with some rare exceptions. The figures below are generated only from the results of these void input decks. The standard deviations and the results of the tallies for both the void and the slab-man runs are included as Appendix B. To obtain these figures, a C program was written to strip the data to a text file for further manipulation in an Excel spreadsheet. This program is included as Appendix F.

8.1 Hand Calculation Results

Detector	Radius cm	Max Dose	Min Dose	Actual Dose
Tally 1	327.18	0.824	0.0274	0.502
Tally 2	220.95	1.77	0.059	0.576
Tally 3	307.68	0.929	0.031	0.634
Tally 4	174.49	2.8	0.093	0.364
Tally 5	184.35	2.52	0.084	1.72
Tally 6	119.70	5.74	0.191	1.4
Tally 7	258.43	1.31	0.043	0.864
Tally 8	133.32	4.68	0.156	1.74
Tally 9	267.62	1.22	0.041	0.909
Tally 10	168.76	2.98	0.099	2.22
Tally 11	308.00	0.927	0.031	0.315
Tally 12	191.41	2.34	0.078	0.685
Tally 13	287.20	1.13	0.038	0.676
Tally 14	135.15	4.56	0.152	1.22
Tally 15	147.66	3.85	0.128	2.29
Tally 16	46.33	32.1	1.07	27.8
Tally 17	233.68	1.56	0.053	0.303
Tally 18	74.79	13.7	0.457	0.929
Tally 19	243.80	1.46	0.049	0.143
Tally 20	127.66	5.08	0.169	0.408

Table 2: Hand validation of MCNP results.

Table 2 above illustrates the validation of the actual, or MCNP code, dose results by using hand calculations. The case validated is the case in which the maximum dose rate occurs, and each of the 20 tally points in MCNP is validated through the hand calculation method previously described in order to verify that the code determines a reasonable dose rate for each tally point. The shielding for the minimum dose rate calculations is 1.5 inches of lead, which, despite being an average number, is enough to bound the data. The calculations show that for each tally point the MCNP results are realistic. This is also illustrated in Figure 8 below.

Hand Calculation Validation

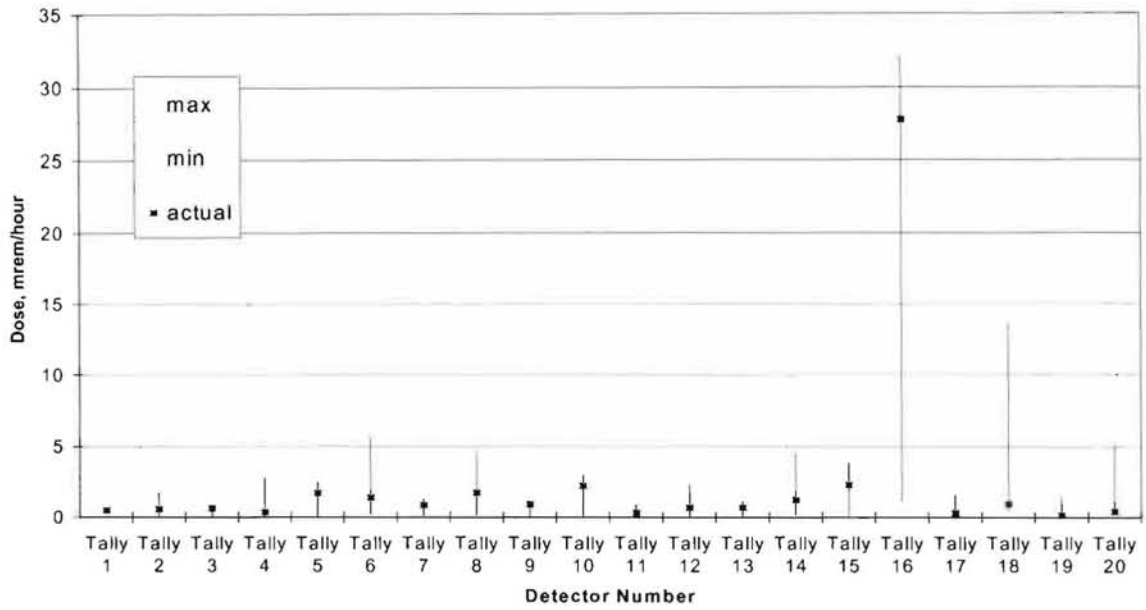

Figure 8: Graphical depiction of validity of the MCNP results using hand calculations.

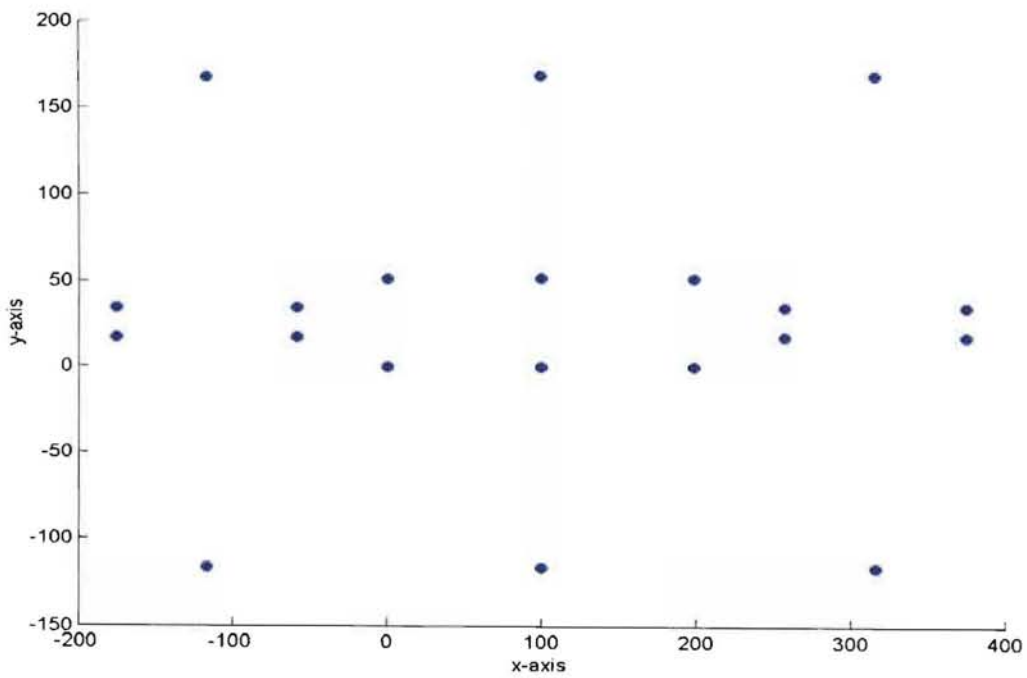

Figure 9: Detector Point Locations in X-Y Axis

Figure 9 shows how the detectors are located with respect to the PET machine after the detectors are “flipped” about the y-axis. The machine is located in the center of the figure between 0 and 50 on the y-axis and 0 and 200 on the x-axis. Figures 10 and 11 illustrate how the detectors are located on two X-Y planes in a symmetric distribution throughout the room. These detectors, or tallies, are positioned in 2 layers at 2 and 5 feet from the concrete floor. As mentioned, each layer consists of 10 detectors that are “flipped” about the y-axis for symmetry to achieve a map of 20 detectors per layer. Although more detectors would have produced more accurate dose maps for each of the cases, only 20 detectors are used because that is the maximum number that MCNP allows.

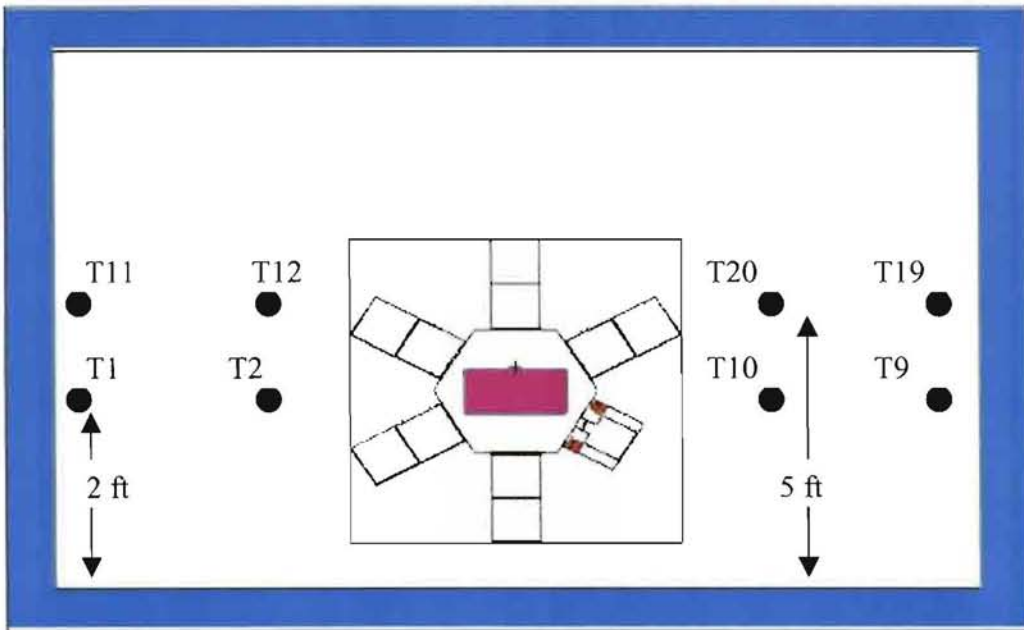

Figure 10: X-Z View of Room with Detector Tallies

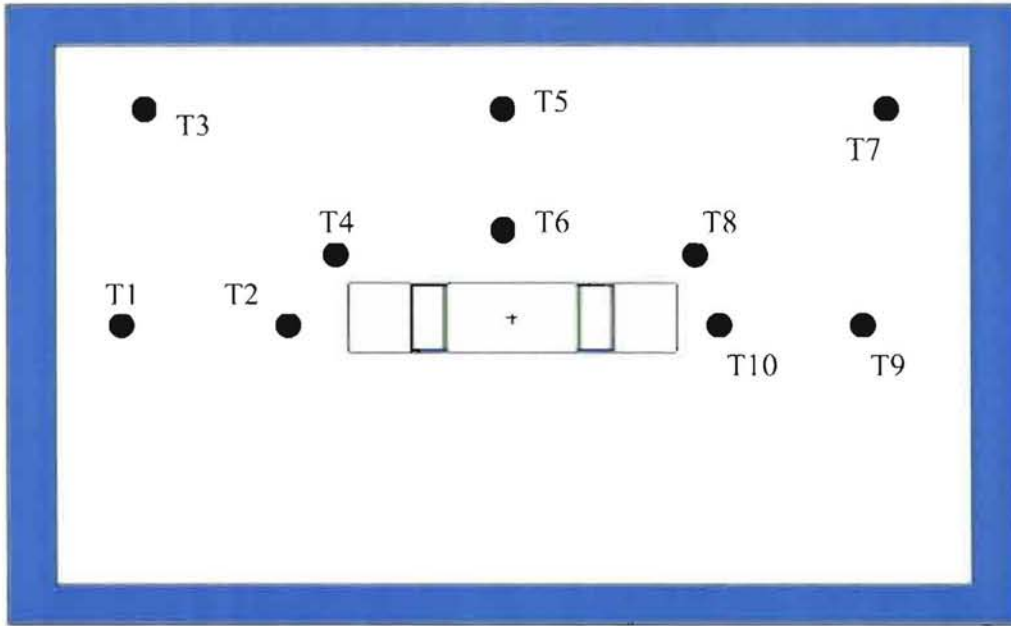

Figure 11: X-Y View of Room with Detector Tallies

8.2 MCNP Results

The results below from MCNP are charted using a function in Matlab (meshgrid) that interpolates values to the nearest data point. All the isoplots below are created by averaging each tally over all the source locations, while weighting the two side positions (upper right and lower right) doubly since symmetry is assumed for the room. This is done to smooth the effects of the source moving vertically. These tally numbers are then averaged equally with their symmetric opposites. That is, the leftmost points above are averaged with the right most points above, e.g. the average of tallies 2 and 10 were averaged. This is done to smooth the effects of the source moving horizontally. The remaining direction is always symmetric. Thus, the plots below should give an approximation of the effects of the source spinning around the scanning bed, as it would be in normal operation. Each Matlab plot figure shown below is calculated without the slab man included in the model. They are also further identifiable by the characteristics shown in Table 3.

Parameter	Variable 1	Variable 2
Source Type	Germanium	Sodium
Source Type	Shielded	Exposed
Shielding Material	Lead	Tungsten
Detector Distance from the Concrete Floor	5ft	2ft

Table 3: Matlab plot characteristics

8.2.1 Germanium Source

8.2.1.1 Germanium/Exposed Source

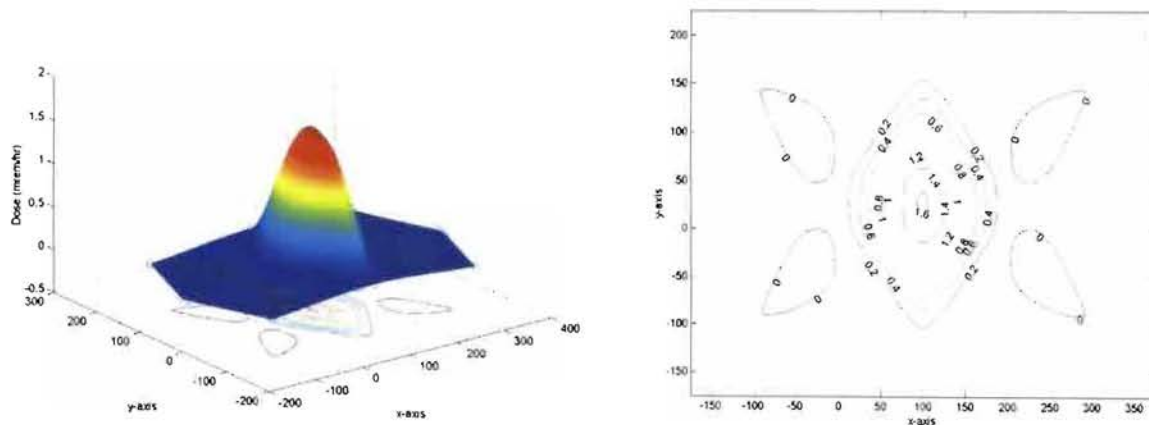

Figure 12: Germanium/Exposed/Lead/5ft

Figure 12 shows the dose map for the exposed, Germanium sources with lead shielding, with the detectors at 5 ft from the ground. This is the worst-case scenario for all the Germanium sources. The peak dose occurs at approximately 1.6 mrem/hour.

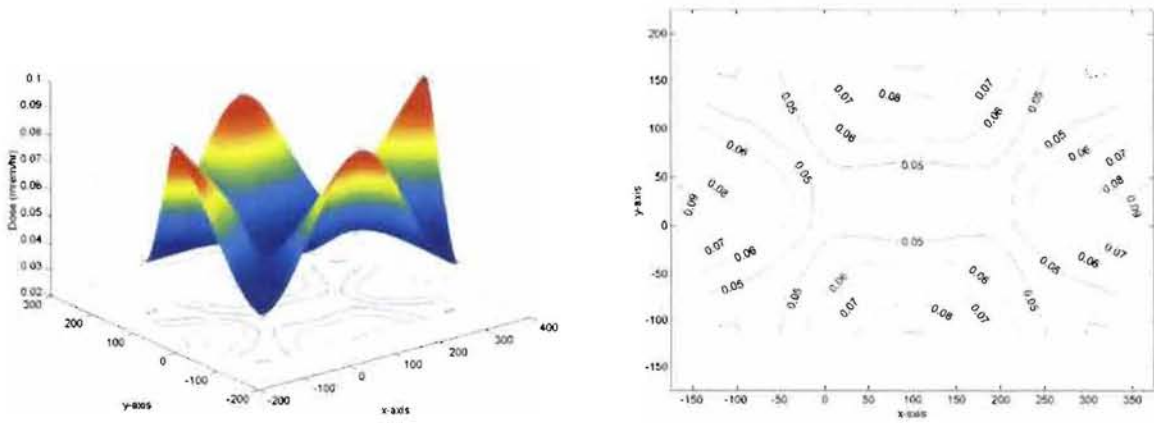

Figure 13: Germanium/Exposed/Lead/2ft

The doses in Figure 13 (exposed Germanium source with lead shielding and detectors positioned 2 ft from the floor) are highest on the edges here by a small factor, most likely because at a height of 2 feet the reflection effects from the walls are greater than the shielding obtained at 2 feet. It is important to note that source is not truly spinning in this MCNP data, the data for these plots are being taken at fixed locations that might be shielded during all of the actual source configurations because of their proximity to the detector. This is the general trend for all the 2-foot data.

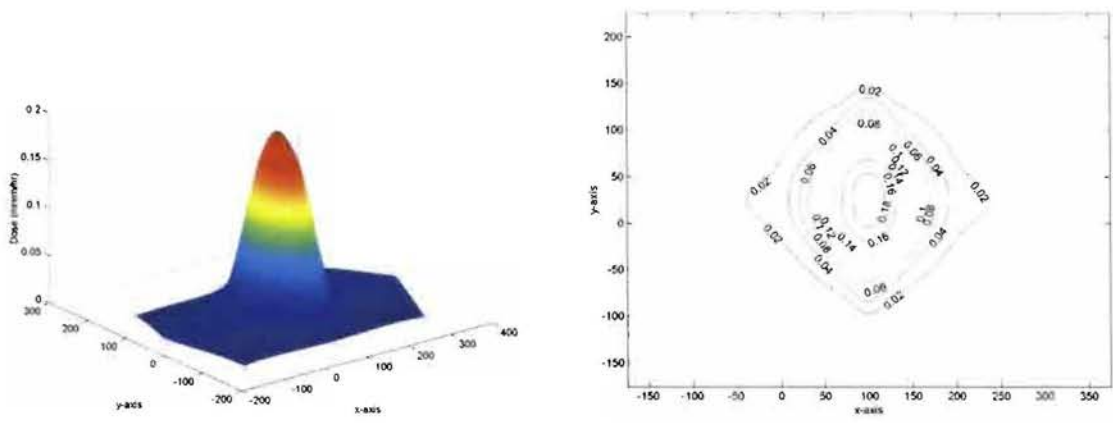

Figure 14: Germanium/Exposed/Tungsten/5ft

The data in Figure 14 shows the results from the exposed Germanium sources with tungsten shielding and detectors points located at 5 ft from the ground. These results are largely the same as in the Lead case, except that all numbers are reduced due to the better attenuation properties of Tungsten.

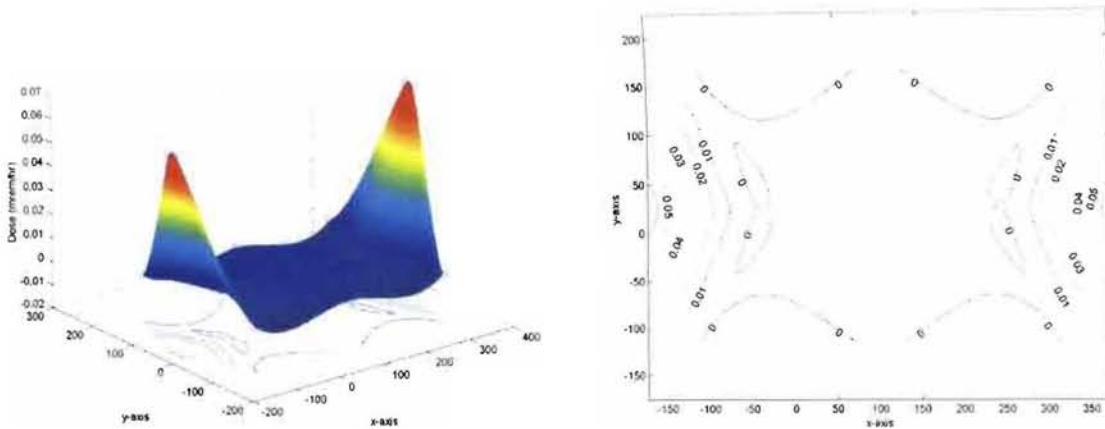

Figure 15: Germanium/Exposed/Tungsten/2ft

Again the data in Figure 15, for exposed Germanium sources with tungsten shielding and detectors located at 2 ft from the ground, are similar to the Lead case, but there is a significant decrease in dose to the y-axis sides of the PET scanner. This is likely because the gammas are almost never leaving the shielding in this direction, but, because this is an exposed case, some gammas are traveling through the LSO to the wall.

8.2.1.2 Germanium/Shielded Source

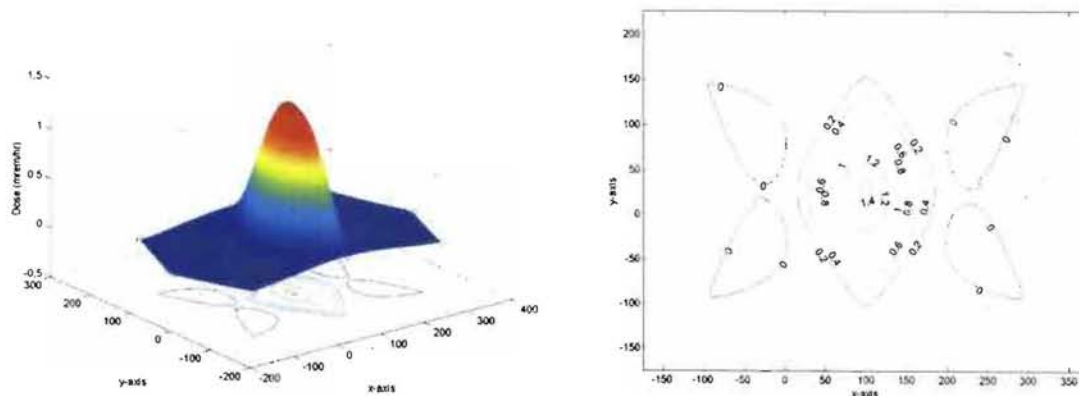

Figure 16: Germanium/Shielded/Lead/5ft

The effects of shielding the Germanium source shown in Figure 16, for shielded Germanium sources with lead shielding and detectors located at 5 ft from the ground, is again to lower the magnitudes of the doses at the 5-foot level. The maximum dose rate is about 1.5 mrem/hour.

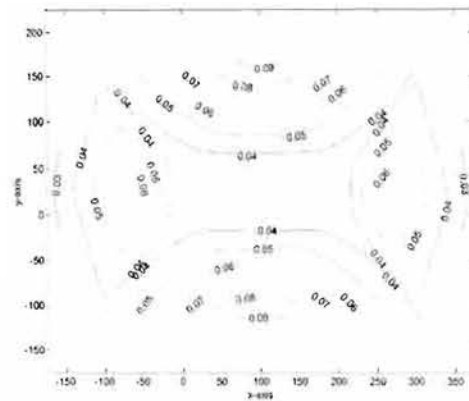
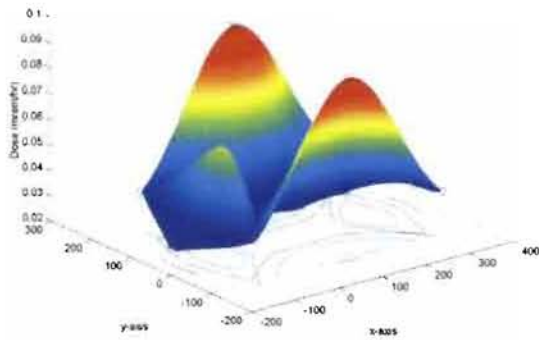

Figure 19: Germanium/Shielded/Tungsten/2ft

Once again, Figure 19, showing shielded Germanium sources with tungsten shielding and detectors located at 2 ft from the ground is nearly identical to the Germanium, shielded, lead picture at 2 feet except the dose rates are depressed due to the better attenuation properties of Tungsten. The maximum dose rate is 0.09 mrem/hour, as opposed to 0.5 mrem/hour for Lead.

8.2.2 Sodium Source

8.2.2.1 Sodium/Exposed Source

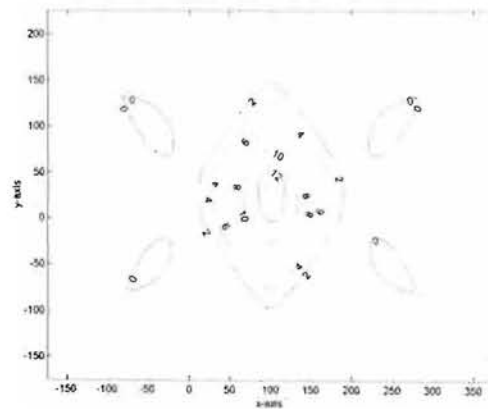
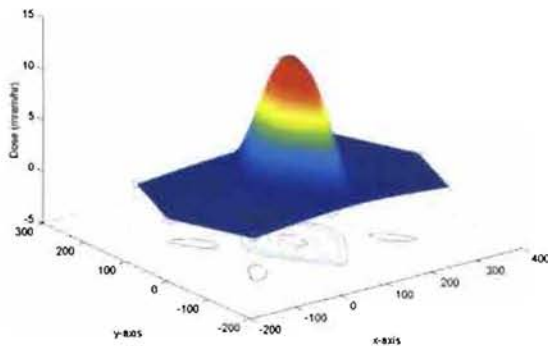

Figure 20: Sodium/Exposed/Lead/5ft

Figure 20, for exposed Sodium sources with lead shielding and detectors located at 5 ft from the ground, is the worst case for dose rates of all the runs, since Sodium emits more high-energy gammas than Germanium, Lead is a worse attenuator than Tungsten, and the sources are exposed

here. The maximum dose rate is for this arrangement is around 13 mrem/hour. The geometry of the figure is the same as that for the Germanium case, which is to be expected.

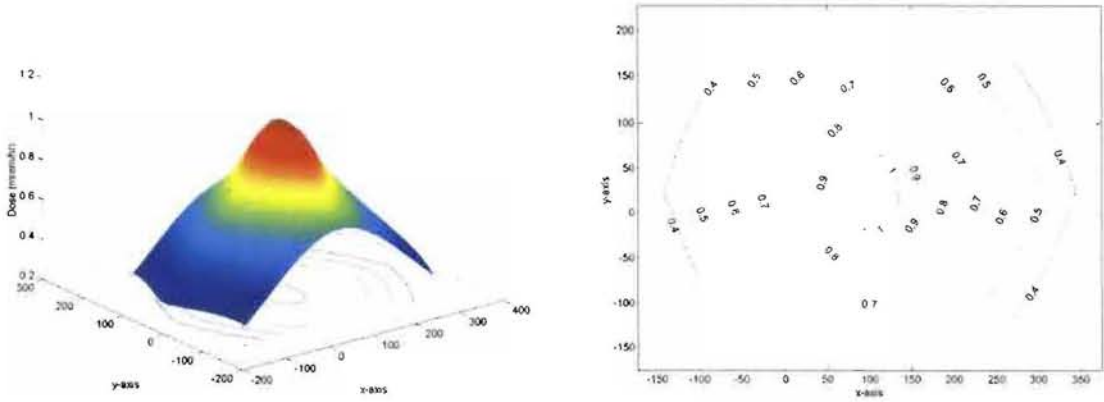

Figure 21: Sodium/Exposed/Lead/2ft

Figure 21, for exposed Sodium sources with lead shielding and detectors located at 2 ft from the ground, shows that at 2 feet the Sodium source shows a marked variation from the equivalent Germanium source. This is due to the frequency of the higher energy gamma, and its ability to penetrate through whatever shielding is seen at this height. The effects of reflection from the walls are nearly negligible compared to the source itself, but still act to keep the dose rates from falling as $1/r^2$.

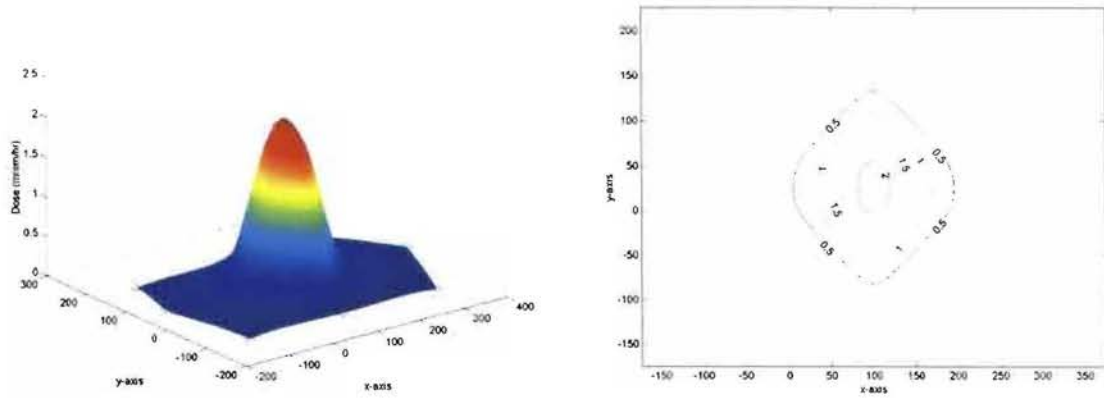

Figure 22: Sodium/Exposed/Tungsten/5ft

Figure 22, for exposed Sodium sources with tungsten shielding and detectors located at 5 ft from the ground, shows that changing to Tungsten for shielding decreases the maximum dose rate by a factor of 6 or so. The dose rate map still has the same form as the earlier case.

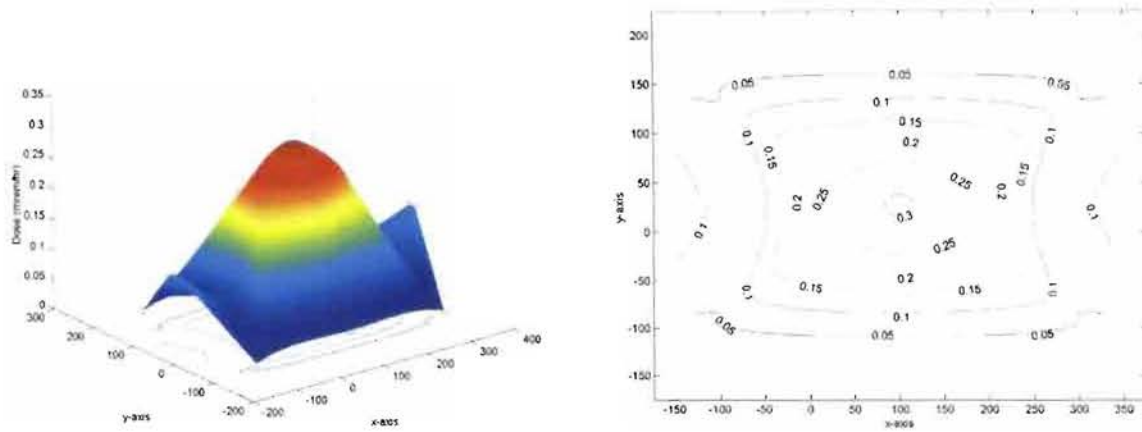

Figure 23: Sodium/Exposed/Tungsten/2ft

Figure 23 shows results for exposed Sodium sources with tungsten shielding and detectors located at 2 ft from the ground. Changing to Tungsten for shielding also brings back the effects of reflection from the walls, which re-elevate the dose rate to 0.1 mrem/hour at the edges. The peak dose rate in Figure 23 is 0.3 mrem/hour, which is a factor of three lower than the equivalent lead case.

8.2.2.2 Sodium/Shielded Source

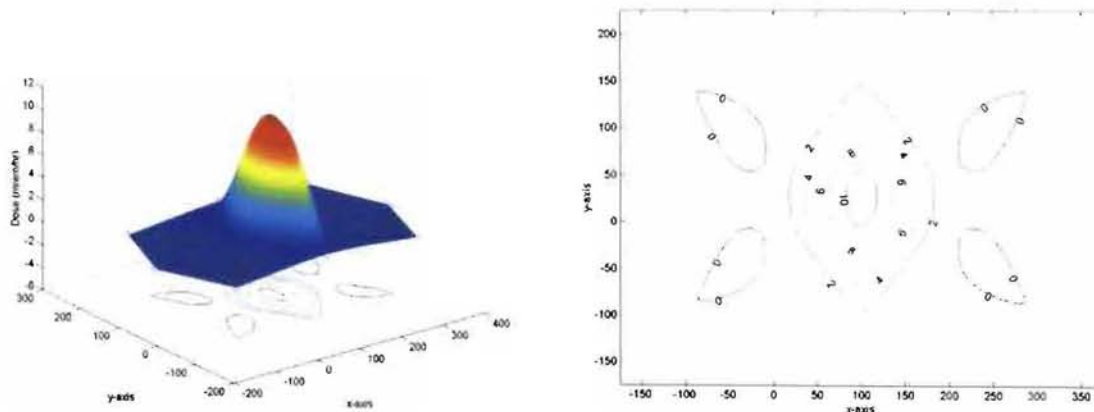

Figure 24: Sodium/Shielded/Lead/5ft

Figure 24 shows the results for shielded Sodium sources with lead shielding and detectors located at 5 ft from the ground. It is surprising to report that covering the sources with Lead has little effect on the dose map. Instead of a peak of 13 mrem/hour, the peak is around 10

mrem/hour. It may be concluded from Figure 24 that if a Sodium source is used, Tungsten may have to be the shielding material.

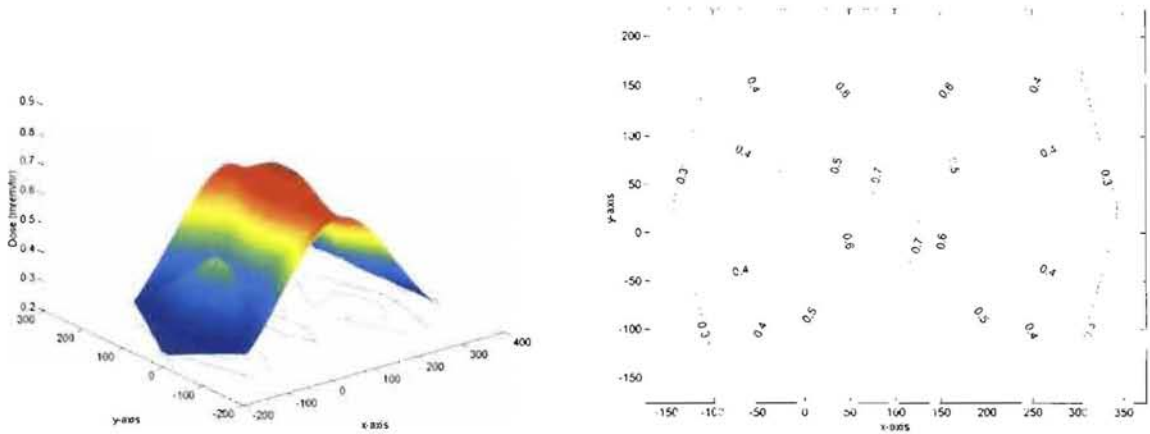

Figure 25: Sodium/Shielded/Lead/2ft

Figure 25, for shielded Sodium sources with lead shielding and detectors located at 2 ft from the ground, differs from the equivalent unshielded Sodium source in that the middle peak is removed. In that figure, the dose rate at the edge of the y-axis is the same as the peak here, which explains why the dose rate is nearly uniform along this axis.

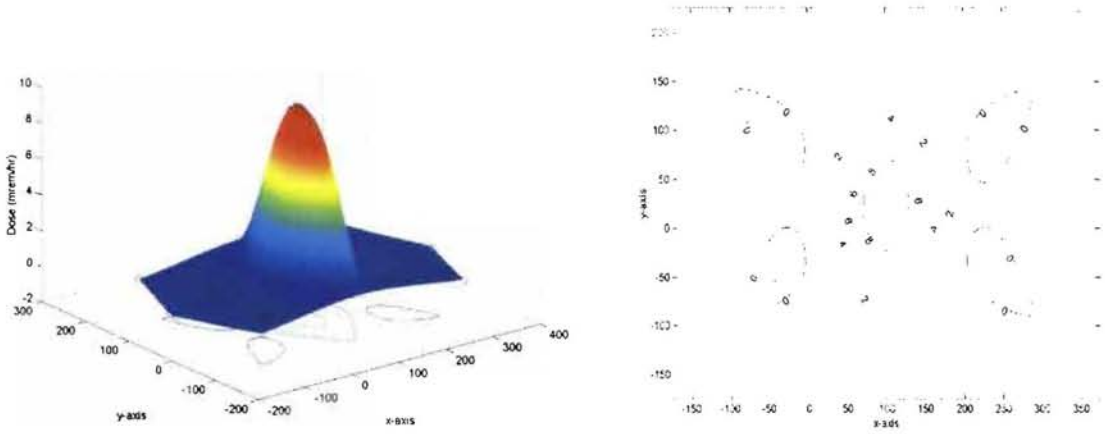

Figure 26: Sodium/Shielded/Tungsten/5ft

Figure 26 shows the results for shielded Sodium sources with tungsten shielding and detectors located at 5 ft from the ground. With Tungsten as an attenuator, the maximum dose rate is about 20% that of the equivalent lead case. Figure 26 geometry remains the same as in earlier runs.

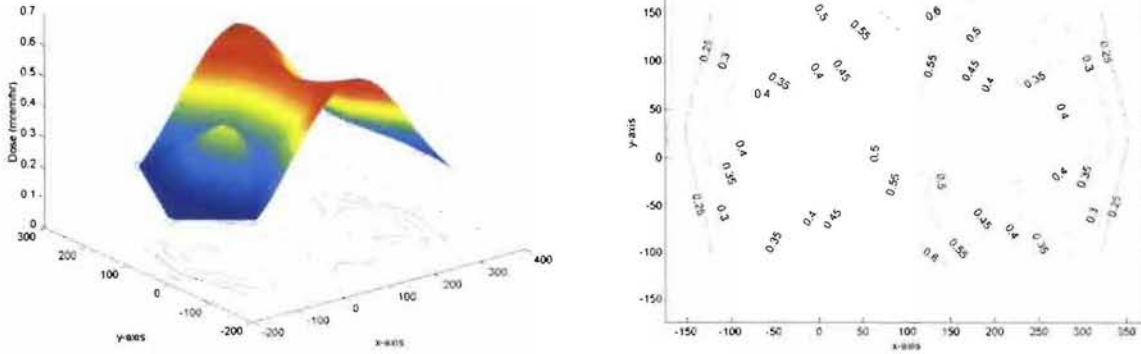

Figure 27: Soidum/Shielded/Tungsten/2ft

Finally, with Figure 27 showing the results for shielded Sodium sources with tungsten shielding and detectors located at 2 ft from the ground, the effects of reflection are clearly seen, as this is the case containing the most shielding and is thus the case most like the earlier Germanium cases. The maximum dose rate here is 0.6 mrem/hour.

8.3 Z-dependence

Having examined dose maps in the X-Y plane, it is also important to address the effects of source location on doses in the Z-axis. One might postulate that the greatest effect would be seen in the cases where the sources are on the bottom, since that is the point that would create the most reflection. To analyze this, the data from all the top detectors is averaged and divided by the average of all the bottom detectors. Figure 28 illustrates this effect:

Z - Dependence for Source Configuration

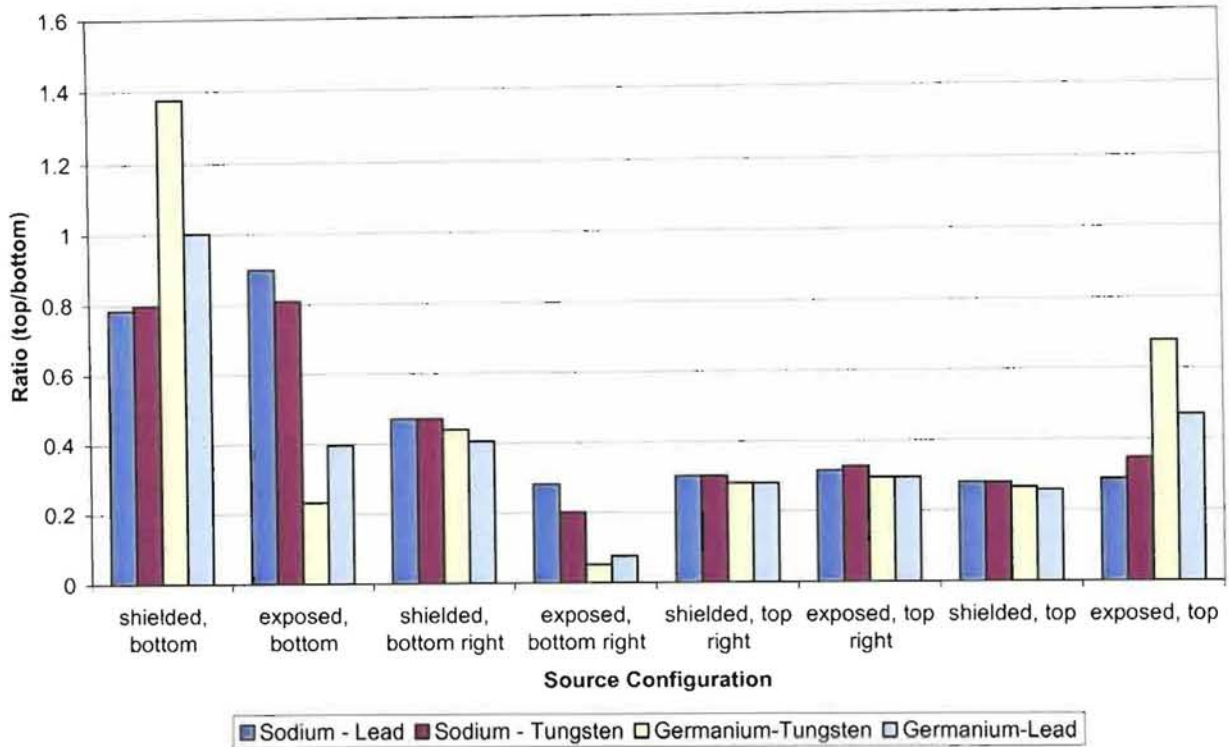

Figure 28: Z-Dependence for Source Configuration

As expected, for all source configurations, the bottom source position has the greatest effect on the ratio of average doses from the top detectors to the bottom detectors. That is because when the source is on the bottom, not only is the majority of the radiation directed upwards, but some of the downward radiation is reflected from the high-density concrete floor. Keep in mind that these cases are not necessarily the ones having the most dose, but the ones having the greatest variation from the detectors located at $z = 2\text{ft}$ to those located at $z = 5\text{ft}$.

8.4 Approximated Annual Dose Calculations

Figure 29 below illustrates the results of the approximated dose for a hypothetical technician.

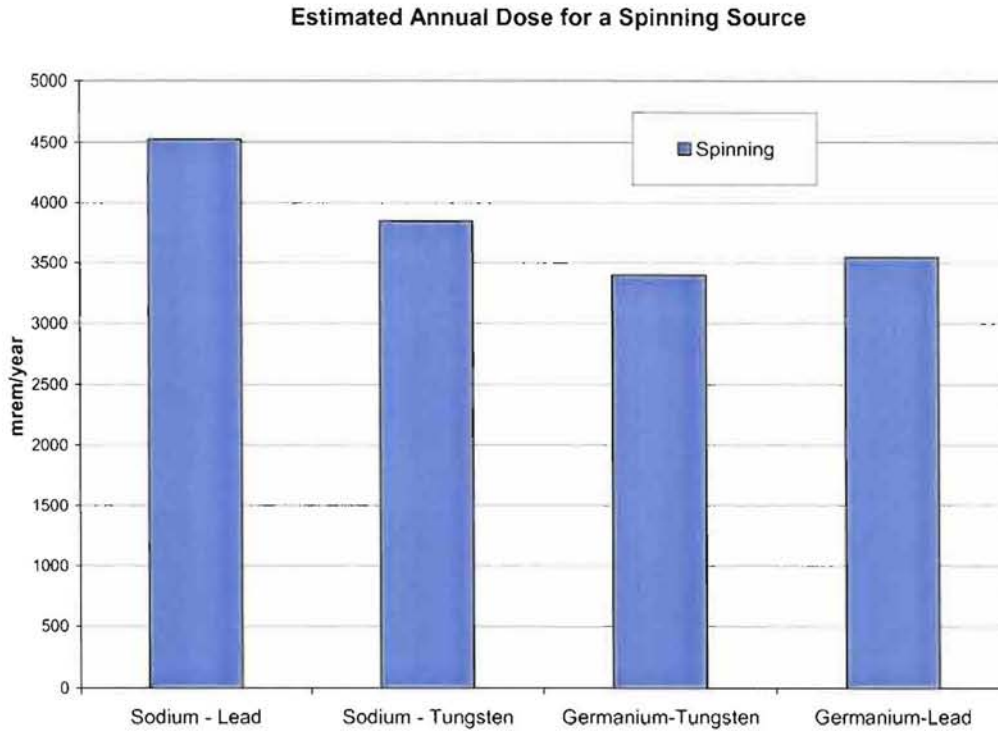

Figure 29: Estimated Annual Dose for One Technician

All of the cases are under the 5 Rem/year limit. As expected, the Sodium-Lead configuration is the highest contributor, and Germanium-Tungsten is the lowest. The interesting result is that one could choose the Sodium-Tungsten configuration and still have a safety margin exceeding 1 Rem/year. An evaluation of the static sources shows that most of the dose at this level is contributed by the top right source configuration, which is to be expected, since at this height the source from the PET machine is nearly equal with the detector locations. This is seen in figure 30, below.

Estimated Annual Dose for One Technician, Static Source

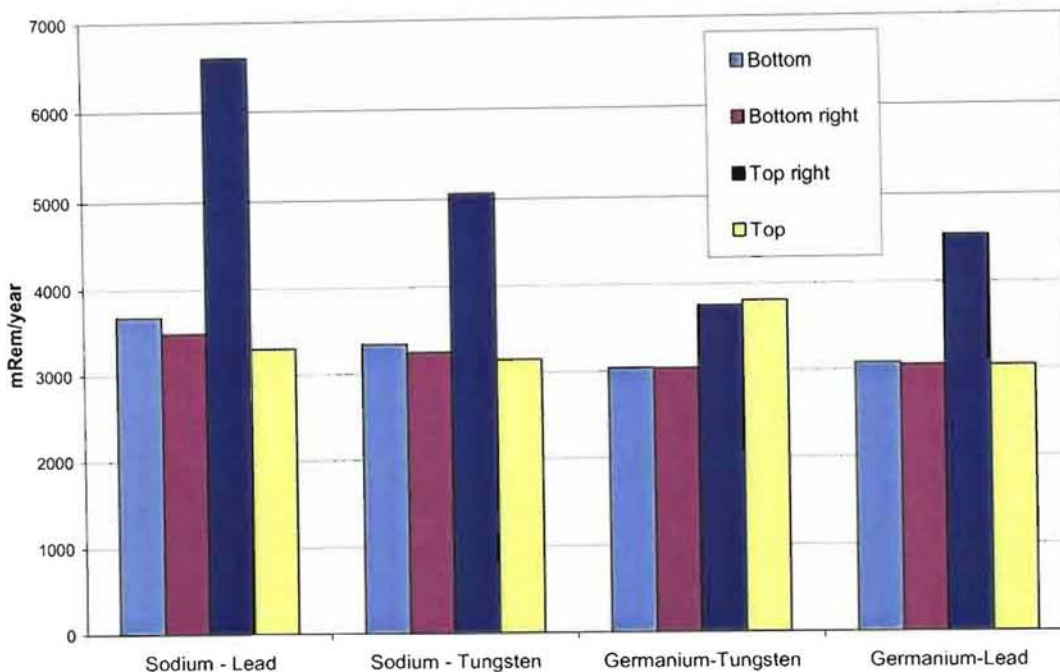

Figure 30: Estimated Annual Dose for One Technician, Static Sources

In the worst-case scenario of leaving the PET machine at this source position, the Sodium-Lead configuration would exceed the federal limit by 1600 mRem. The Sodium-Tungsten configuration, however, quite nearly meets this limit; it is only over by 60 mRem. It is economically advantageous to choose Sodium-22 over Germanium-68, since Sodium-22 costs \$25.00/mCi and Germanium-68 is \$330.00/mCi. Not only that, but the half-life of Sodium-22 is 2.6 years while the half-life of Germanium-68 is 271 days. Thus, for the source material, analyses show that Sodium-22 is the better choice when all factors are considered.

However, in keeping with the results shown in figure 21, Tungsten should be the shielding material. It is well known that Tungsten is more expensive than Lead. This is a one-time cost, however, and the increased safety margin is enough reason to use this material. Additional reasons not related to the analyses in this report are that Tungsten does not pose the chemical threat to humans that Lead does, and Tungsten is more aesthetically pleasing.

9.0 Conclusions

Results of the hand calculations demonstrate that the MCNP results are valid. All the tally points for the case containing the highest dose rates fell between the upper and lower bounds of the hand calculations.

Even before these results were compiled, it was apparent that to minimize dose rates, CTI should choose Tungsten as an attenuator and Germanium as the source. However, results show that if the Germanium source is chosen, then it does not make very much difference which attenuator is used. In the shielded case, the difference between the maximum doses on the 5-foot level is less than 10%. On the 2-foot level the difference is a factor of ten, but this is on the order of tenths of a mrem/hr. Since Lead is less expensive than Tungsten, some cost savings are possible.

For the Sodium source, however, Tungsten should certainly be used as the attenuator. The results of section 8.2 show that using Tungsten in the shielded case at the 5-foot level results in a savings of 20% in dose rates; in the exposed cases this number jumps to a factor of 6 difference. The results of section 8.4 show more unambiguously that the Sodium-Tungsten configuration is the optimal design, since for this configuration the hypothetical technician receives less than 4 R/year, which is well under the 5 Rem/year total effective dose equivalent limit stated in 10 CFR 20.1201. Sodium-22 is the optimal source material due to economic incentives. Tungsten is the optimum shielding material due to radiological, chemical, and aesthetic reasons.

The worst-case scenario for Z-dependence is when the source location is on the bottom of the scanner, and it is seen in cases containing heavy shielding or weak sources that reflection off the concrete is present. Reflection is only important at very low dose rates, however.

Details of the P-39 PET Scanner geometry were limited, and this effected the precision of the results printed here. In all cases these analyses are intended to err on the conservative side from a dose standpoint, so the final design recommendations should be conservative. In addition, these analyses may be useful as parameterization studies in their own rite.

10.0 Recommendations for Future Work

Only twenty data points were modeled at each of the two heights to create the dose rate maps. Obtaining more data points at each height would result in a much more accurate, detailed dose rate map of the room. Accomplishing this requires many more MCNP cases due to the limit of tally points per case run.

Several aspects of the scanner were not included in the MCNP model, such as wiring, scanner casing, and the patient's bed. The contribution from these items to gamma attenuation was generally assumed negligible, but their inclusion in a model would provide data that are even more accurate. The absence of such features, however, may provide additional conservatism depending on the scope of the analysis.

11.0 References

CTI Inc. 2001. <http://www.triumf.ca/welcome/petscan.html>.

Goldmeyer, Dr. Franz. Personal Contact from Oak Ridge National Laboratory, February, 2002.

Lederer, Michael C., Jack M. Hollander, and Isadore Perlman. Table of Isotopes. Sixth Edition. John Wiley & Sons, Inc., New York, 1968.

Los Alamos National Laboratory-Transport Methods Group. Monte Carlo N Particle Transport Code System. Radiation Safety Information Computational Center, Oak Ridge, TN, 1998.

Pevey, Dr. Ronald. Personal Contact from the University of Tennessee, Knoxville, Nuclear Engineering Department, February 2002.

P.E.T. Net Pharmaceuticals. 2001. <http://www.petnetpharmaceutical.com/html/rad-saf.htm>

Shultis, J. Kenneth, and Richard E. Faw. Radiation Shielding. Prentice Hall PTR, UpperSaddle River, NJ, 1996.

Table of Nuclides. Nuclear Data Evaluation Lab and Korea Atomic Energy Research Institute. 2002. <http://www2.bnl.gov/ton/index.html>.

Thompson, Dr. Wayne. Lecture and Personal Contact from the University of Tennessee Medical Center, February 2002.

Oak Ridge National Laboratory Isotope Business Office

Appendix A: Typical MCNP Input File

```

Final run
C   Cell Cards
1   0                1 -2 3 -4 5 -6 #3 #4 #5 #6 #7 #8 #9 #15 #26
                        #28 #30 #31 #32 #33 #35 #36 #37 #38 #39 #40
                        #51 #52 #53 #54 #45 #46 #47 #48                imp:p=1
3   0                3 -4 15 -16 14 17 10 -11 #4                imp:p=1
C   Cell for slab man
4   4 4.98825e-5      18 -19 20 -21 3 -4                imp:p=1
C   Cells for Top detector
5   2 7.7838e-2       11 -26 31 -32 38 -39                imp:p=1
51  0                 26 -27 31 -32 38 -39                imp:p=1
52  3 6.0525e-2       7 -8 3 -4 11 -28 (-31:32:-38:39:27)        imp:p=1
53  0                 29 -30 31 -32 38 -39                imp:p=1
54  5 8.5168e-2       7 -8 3 -4 28 -12 (-31:32:-38:39:-29:30)    imp:p=1
c box around the pet detector
10  0                 51 -52 55 -56 58 -60 #1 #3 #4 #5 #6 #7 #8 #9
                        #15 #26 #28 #30 #31 #32 #33 #35 #36 #37 #38
                        #39 #40 #51 #52 #53 #54 #45 #46 #47 #48        imp:p=1
C   Cells 15, 6-9 are for the top left-hand detector
15  2 7.7838e-2       -97 96 38 -39 -15 98                imp:p=1
6   0                 -97 96 38 -39 -98 99                imp:p=1
7   3 6.0525e-2       -101 102 3 -4 -15 100 (97:-96:-38:39:-99)    imp:p=1
8   0                 -97 96 38 -39 -115 116                imp:p=1
9   5 8.5168e-2       -101 102 3 -4 -100 95 (97:-96:-38:39:115:-116)    imp:p=1
C   these cells are for the top right-hand detector
26  2 7.7838e-2       80 -79 38 -39 16 -78                imp:p=1
30  0                 80 -79 38 -39 78 -81                imp:p=1
31  3 6.0525e-2       76 -77 3 -4 16 -82 (79:-80:-38:39:81)        imp:p=1
32  0                 80 -79 38 -39 83 -84                imp:p=1
33  5 8.5168e-2       76 -77 3 -4 82 -75 (79:-80:-38:39:-83:84)    imp:p=1
c bottom right-hand detector contains the SOURCE
40  0                 -88 89 500 -501 -17 90 *fill=3 (6)        imp:p=1
c these cells are for the bottom left-hand detector
28  2 7.7838e-2       -108 109 38 -39 -14 110                imp:p=1
45  0                 -108 109 38 -39 -110 111                imp:p=1
46  3 6.0525e-2       106 -107 3 -4 -14 112 (-109:108:-38:39:-111)    imp:p=1
47  0                 -108 109 38 -39 -113 114                imp:p=1
48  5 8.5168e-2       106 -107 3 -4 -112 105 (-109:108:-38:39:113:-114)    imp:p=1
C   11 is the concrete room shell
11  6 8.8524e-2       50 -53 54 -57 59 -61 (-51:52:-55:56:-58:60)    imp:p=1
C   Cells for the Bottom Detector
35  2 7.7838e-2       -10 33 31 -32 38 -39                imp:p=1
36  0                 -33 34 31 -32 38 -39                imp:p=1
37  0                 -36 37 31 -32 38 -39                imp:p=1
38  3 6.0525e-2       7 -8 3 -4 -10 35 (-31:32:-38:39:-34)        imp:p=1
39  5 8.5168e-2       7 -8 3 -4 -35 9 (-31:32:-38:39:36:-37)        imp:p=1
C   Start with the source
c Tungsten half cylinder
201 1 6.5525e-2       -201 202 -203 -204 #203 #208 #209 #210        u=1    imp:p=1
C   Al PMT container
202 3 6.0525e-2       -210 212 215 -216 205 -208
                        (211:-217:218:-206:207)                u=1    imp:p=1
C   Cell for bottom triangle void
203 1 6.5525e-2       -219 220 215 -216 -221 #210                u=1    imp:p=1
204 1 6.5525e-2       219 -220 202 -203 204 -205 #209                u=1    imp:p=1
205 1 6.5525e-2       222 -223 202 -203 204 -205 #204 #209                u=1    imp:p=1
206 3 6.0525e-2       214 -212 215 -216 410 -208
                        (-213:-217:218:-206:207)                u=1    imp:p=1

```

```

C    LSO Filler
207 2 7.7838e-2      212 -211 217 -218 206 -207      u=1      imp:p=1
C    Photomultiplier (PMT) Cell 8
208 0                213 -212 217 -218 206 -207      u=1      imp:p=1
209 0                219 -220 224 -225 204 -205      u=1      imp:p=1
210 0                220 -219 224 -225 -221 -210      u=1      imp:p=1
211 1 6.5525e-2     -221 201 215 -216 219 -226 #202 #207      u=1      imp:p=1
212 1 6.5525e-2     -221 201 215 -216 -220 227 #202 #207      u=1      imp:p=1
C    Tungsten outer rim
213 1 6.5525e-2     212 -210 202 -203 205 -209 #207 #202      u=1      imp:p=1
214 0                214 -210 202 -203 228 -209 #201 #202
                        #203 #204 #205 #206 #207 #208 #209 #210
                        #211 #212 #213 #216      u=1      imp:p=1
215 0                -300 #(214 -210 202 -203 228 -209)      u=1      imp:p=1
216 3 6.0525e-2     229 -212 202 -203 208 -209      u=1      imp:p=1
c    base cell of lattice
300 0                314 -310 302 -303 328 -309
                        imp:p=1 u=2 lat=1 fill=0:0 -10:1 0:0
                        1 1 1 1 1 1 1 1 1 1 1      u=3      imp:p=1
301 0                314 -310 302 -330 328 -309
                        fill=2
302                like 301 but trcl=5      u=3      imp:p=1
400 3 6.0525e-2     -212 407 408 -409 410 -411 (400:-401:-202:330:-404:405)
                        #301 #302      u=3      imp:p=1
401 0                -400 401 202 -330 404 -405 #301 #302      u=3      imp:p=1
C    sphere containing source
500 0                -502 #301 #302 #400 #401      u=3      imp:p=1
C    Begin outer world
50  0                -50:53:-54:57:-59:61      imp:p=0

C    Surface Cards
1    px 1.00
2    px 199.0
3    py 0.0
4    py 50.8
5    pz -23.00
6    pz 188.0
C    Surface Cards for the Bottom Detector
7    px 85.0
8    px 115.0
9    pz -22.27
10   pz 40
31   px 85.3175
32   px 114.6825
33   pz 38.6825
34   pz 8.6825
35   pz 8.365
36   pz 8.0475
37   pz -21.9525
38   py 0.3175
39   py 50.4825
C    Surface Cards for the Top Detector
11   pz 125.15604
12   pz 187.42604
26   pz 126.47354
27   pz 156.47354
28   pz 156.79104
29   pz 157.10854
30   pz 187.10854
C    Surface Cards for the hexagon
14   1 pz 0.00
15   2 pz 0.00
16   3 pz 0.00

```

```

17 4 pz 0.00
C surfaces for slab man
18 px 70
19 px 130
20 pz 67.57802
21 pz 97.57802
C Surfaces for the Room
50 px -205.26
51 px -175.26
52 px 375.26
53 px 405.26
54 py -205.26
55 py -175.26
56 py 226.06
57 py 256.06
58 pz -55.0
59 pz -85.0
60 pz 321.2
61 pz 351.2
C Surfaces for the top-right detector
75 3 pz 62.27
76 3 px -15.0
77 3 px 15.0
78 3 pz 1.3175
79 3 px 14.6825
80 3 px -14.6825
81 3 pz 31.3175
82 3 pz 31.635
83 3 pz 31.9525
84 3 pz 61.9525
C Surfaces for the bottom-right detector
85 4 pz -62.27
86 4 px -15.0
87 4 px 15.0
88 4 px 18.65125
89 4 px -18.65125
90 4 pz -34.572
91 4 pz -31.3175
92 4 pz -31.635
93 4 pz -31.9525
94 4 pz -61.9525
C Surfaces for the Source on the top-left side
95 2 pz -62.27
96 2 px -14.6825
97 2 px 14.6825
98 2 pz -1.3175
99 2 pz -31.3175
100 2 pz -31.635
101 2 px 15.0
102 2 px -15.0
115 2 pz -31.9525
116 2 pz -61.9525
C Surfaces for the bottom-left detector
105 1 pz -62.27
106 1 px -15.0
107 1 px 15.0
108 1 px 14.6825
109 1 px -14.6825
110 1 pz -1.3175
111 1 pz -31.3175
112 1 pz -31.635
113 1 pz -31.9525
114 1 pz -61.9525

```

```

C    Start with the source
201  c/y 0 0 3.33502
202  py 0
203  py 5.08
204  pz 0
205  pz 0.3175
206  pz 0.635
207  pz 4.46532
208  pz 4.78282
209  pz 5.73532
210  px 3.65125
211  px 3.33375
212  px -3.65125
C    Surface Cards for the al for PMT
213  px -11.30021
214  px -11.61771
215  py 1.4732
216  py 3.6068
217  py 1.7907
218  py 3.2893
C    Surface Cards for the Cut Triangle
219  7 pz 0.0
220  8 pz 0.0
221  c/y 0 0 4.571
C    Surface cards for the Box on top of cylinder
222  px -3.335
223  px 3.335
C    Surface Cards #25 #25 for the gap
224  py 2.2911
225  py 2.7889
226  7 pz 0.3175
227  8 pz -0.3175
C    Surface Cards for the Universe 1 (Source)
228  pz -4.572
229  px -3.96875
c    Surfaces for lattice
300  so 50
310  px 3.65124
314  px -11.61770
302  py 0.00001
303  py 5.07999
328  pz -4.57199
309  pz 5.73531
330  py 50.79999
c    Surfaces for box containing sources (inside)
400  px -3.96875
401  px -26.03125
404  pz 0
405  pz 29.6825
c    (outside)
407  px -26.34875
408  py -0.3175
409  py 51.1175
410  pz -0.3175
411  pz 30
412  px -33.65125
C    py surfaces for source fill
500  py -0.3175
501  py 51.1175
502  so 75
C    smaller surfaces for source lattice
503  px -33.65115
504  px 3.65115

```

```

505 py -0.3174
506 py 51.1174
507 pz -4.5719
508 pz 29.9999
c surfaces for putting source in top detector box
307 px 81.349
308 px 118.651
338 py -0.3175
339 py 51.1175

SDEF POS D2 ERG=D1 PAR=2
MODE P
SI1 L 0.511 0.0294351 0.477639072 0.227 0.455 0.48341 0.57853 0.68263
      0.80583 0.93873 1.07733 1.1661 1.26102 1.74442 1.883 2.3384 2.8216
      0.00922 0.00925 0.0102 0.0104 0.00862 0.00864 0.0096
SP1 D 0.499704323 0.003084595 0.246767567 3.11264E-07 2.52376E-07
      6.89828E-07 8.83316E-05 8.16015E-07 0.000236392 4.62689E-06
      0.008412531 4.20627E-08 0.000231345 2.4817E-05 0.000386976
      2.60788E-06 1.16934E-09 0.064496069 0.128992137 0.024508506
      0.000773953 0.006631878 0.013263757 0.002387476
SI2 L 147.98 2.54 72.162 147.98 7.62 72.162 147.98 12.7 72.162
      147.98 17.78 72.162 147.98 22.86 72.162 147.98 27.94 72.162
      147.98 33.02 72.162 147.98 38.1 72.162 147.98 43.18 72.162
      147.98 48.26 72.162 132.91 2.54 46.127 132.91 7.62 46.127
      132.91 12.7 46.127 132.91 17.78 46.127 132.91 22.86 46.127
      132.91 27.94 46.127 132.91 33.02 46.127 132.91 38.1 46.127
      132.91 43.18 46.127 132.91 48.26 46.127
SP2 D 1 1 1 1 1 1 1 1 1 1 1 1 1 1 1 1 1 1 1 1 1 1 1 1 1 1 1 1 1 1 1 1
c The next 2 lines are source info for Sodium
c SI1 L 0.511 0.170373 0.011891 1.27453
c SP1 D 0.486419219 0.000151499 0.243047289 0.270381993
*TR1 63.12635 0 61.28901 120 90 30 90 0 90 30 90 120
*TR2 63.12635 0 103.86703 -120 90 150 90 0 90 -30 90 -120
*TR3 136.87365 0 103.86703 -60 90 -150 90 0 90 30 90 -60
*TR4 136.87365 0 61.28901 60 90 -30 90 0 90 150 90 60
C transformation card for use in source (302 like 301)
*TR5 -30 50.79999 0 180 90 90 90 180 90 90 0
*TR6 133.33312 0.0 46.01263 120 90 150 90 0 90 -30 90 60
C Right side line
*TR7 2.2315 0 -2.4784 48 90 138 90 0 90 -42 90 48
C Left side line
*TR8 -2.2315 0 -2.4784 132 90 -138 90 0 90 48 90 132
C Material Cardsy
C tungsten alloy
m1 74182 1.5990E-02 74183 8.5874E-03
    74184 1.8287E-02 74186 1.6785E-02
    26054 1.1038E-04 26056 1.6710E-03 26057 3.7912E-05
    26058 4.9585E-06
    28058 2.7929E-03 28060 1.0400E-03 28061 4.4466E-05
    28062 1.3950E-04 28064 3.4414E-05
C LSO
m2 67165 1.945948E-02
    8016 4.864870E-02
    14000 9.729739E-03
C Al alloy
m3 13027 6.0140E-02
    25055 3.5910E-04
    29063 1.7722E-05 29065 8.1498E-06
C Air
m4 7014 3.91294e-5
    8016 1.07456E-5
    6000 7.49170E-9
C steel 1020

```

```

m5  6000 7.8429E-04
    14000 4.1925E-04
    25055 3.8580E-04
    26054 4.93117E-03
    26056 7.66588E-02
    26057 1.75516E-03
    26058 2.34022E-04
C High Density Concrete (3.93 g/cc)
m6  1001 9.1120E-03
    8016 4.9320E-02
    11023 1.0290E-05
    12000 2.0920E-04
    13027 4.8710E-04
    14000 1.7000E-03
    15031 7.6420E-06
    16000 8.1180E-05
    19000 1.2110E-05
    20000 2.4710E-03
    22000 2.6440E-04
    25055 3.8780E-05
    26054 1.46379E-03
    26056 2.27557E-02
    26057 5.21010E-04
    26058 6.94680E-05
F015:P -174.96 33.8667 5.96 0.28209
F025:P -57.8533 33.8667 5.96 0.28209
F035:P -116.3644 167.4986 5.96 0.28209
F045:P 1.2127 51.0115 5.96 0.28209
F055:P 100 167.75 5.96 0.28209
F065:P 100 51.1 5.96 0.28209
F075:P 316.3644 167.4986 5.96 0.28209
F085:P 199.2127 51.0115 5.96 0.28209
F095:p 374.96 33.8667 5.96 0.28209
F105:P 257.8533 33.8667 5.96 0.28209
F115:P -174.96 33.8667 97.4 0.28209
F125:P -57.8533 33.8667 97.4 0.28209
F135:P -116.3644 167.4986 97.4 0.28209
F145:P 1.2127 51.0115 97.4 0.28209
F155:P 100 167.75 97.4 0.28209
F165:P 100 51.1 97.4 0.28209
F175:P 316.3644 167.4986 97.4 0.28209
F185:P 199.2127 51.0115 97.4 0.28209
F195:p 374.96 33.8667 97.4 0.28209
F205:P 257.8533 33.8667 97.4 0.28209
F066:P 4
DE015 0.01 0.015 0.02 0.03 0.04 0.05 0.06 0.08
      .1 .15 .2 .3 .4 .5 .6 .8 1.0 1.5 2.0 3.0
DF015 2.78e-6 1.11e-6 5.88e-7 2.56e-7 1.56e-7 1.20e-7
      1.11e-7 1.20e-7 1.47e-7 2.38e-7 3.45e-7 5.56e-7
      7.69e-7 9.09e-7 1.14e-6 1.47e-6 1.79e-6 2.44e-6
      3.03e-6 4.00e-6
DE025 0.01 0.015 0.02 0.03 0.04 0.05 0.06 0.08
      .1 .15 .2 .3 .4 .5 .6 .8 1.0 1.5 2.0 3.0
DF025 2.78e-6 1.11e-6 5.88e-7 2.56e-7 1.56e-7 1.20e-7
      1.11e-7 1.20e-7 1.47e-7 2.38e-7 3.45e-7 5.56e-7
      7.69e-7 9.09e-7 1.14e-6 1.47e-6 1.79e-6 2.44e-6
      3.03e-6 4.00e-6
DE035 0.01 0.015 0.02 0.03 0.04 0.05 0.06 0.08
      .1 .15 .2 .3 .4 .5 .6 .8 1.0 1.5 2.0 3.0
DF035 2.78e-6 1.11e-6 5.88e-7 2.56e-7 1.56e-7 1.20e-7
      1.11e-7 1.20e-7 1.47e-7 2.38e-7 3.45e-7 5.56e-7
      7.69e-7 9.09e-7 1.14e-6 1.47e-6 1.79e-6 2.44e-6
      3.03e-6 4.00e-6

```



```

1.11e-7 1.20e-7 1.47e-7 2.38e-7 3.45e-7 5.56e-7
7.69e-7 9.09e-7 1.14e-6 1.47e-6 1.79e-6 2.44e-6
3.03e-6 4.00e-6
DE155 0.01 0.015 0.02 0.03 0.04 0.05 0.06 0.08
      .1 .15 .2 .3 .4 .5 .6 .8 1.0 1.5 2.0 3.0
DF155 2.78e-6 1.11e-6 5.88e-7 2.56e-7 1.56e-7 1.20e-7
      1.11e-7 1.20e-7 1.47e-7 2.38e-7 3.45e-7 5.56e-7
      7.69e-7 9.09e-7 1.14e-6 1.47e-6 1.79e-6 2.44e-6
      3.03e-6 4.00e-6
DE165 0.01 0.015 0.02 0.03 0.04 0.05 0.06 0.08
      .1 .15 .2 .3 .4 .5 .6 .8 1.0 1.5 2.0 3.0
DF165 2.78e-6 1.11e-6 5.88e-7 2.56e-7 1.56e-7 1.20e-7
      1.11e-7 1.20e-7 1.47e-7 2.38e-7 3.45e-7 5.56e-7
      7.69e-7 9.09e-7 1.14e-6 1.47e-6 1.79e-6 2.44e-6
      3.03e-6 4.00e-6
DE175 0.01 0.015 0.02 0.03 0.04 0.05 0.06 0.08
      .1 .15 .2 .3 .4 .5 .6 .8 1.0 1.5 2.0 3.0
DF175 2.78e-6 1.11e-6 5.88e-7 2.56e-7 1.56e-7 1.20e-7
      1.11e-7 1.20e-7 1.47e-7 2.38e-7 3.45e-7 5.56e-7
      7.69e-7 9.09e-7 1.14e-6 1.47e-6 1.79e-6 2.44e-6
      3.03e-6 4.00e-6
DE185 0.01 0.015 0.02 0.03 0.04 0.05 0.06 0.08
      .1 .15 .2 .3 .4 .5 .6 .8 1.0 1.5 2.0 3.0
DF185 2.78e-6 1.11e-6 5.88e-7 2.56e-7 1.56e-7 1.20e-7
      1.11e-7 1.20e-7 1.47e-7 2.38e-7 3.45e-7 5.56e-7
      7.69e-7 9.09e-7 1.14e-6 1.47e-6 1.79e-6 2.44e-6
      3.03e-6 4.00e-6
DE195 0.01 0.015 0.02 0.03 0.04 0.05 0.06 0.08
      .1 .15 .2 .3 .4 .5 .6 .8 1.0 1.5 2.0 3.0
DF195 2.78e-6 1.11e-6 5.88e-7 2.56e-7 1.56e-7 1.20e-7
      1.11e-7 1.20e-7 1.47e-7 2.38e-7 3.45e-7 5.56e-7
      7.69e-7 9.09e-7 1.14e-6 1.47e-6 1.79e-6 2.44e-6
      3.03e-6 4.00e-6
DE205 0.01 0.015 0.02 0.03 0.04 0.05 0.06 0.08
      .1 .15 .2 .3 .4 .5 .6 .8 1.0 1.5 2.0 3.0
DF205 2.78e-6 1.11e-6 5.88e-7 2.56e-7 1.56e-7 1.20e-7
      1.11e-7 1.20e-7 1.47e-7 2.38e-7 3.45e-7 5.56e-7
      7.69e-7 9.09e-7 1.14e-6 1.47e-6 1.79e-6 2.44e-6
      3.03e-6 4.00e-6
ctme 1440

```

Appendix B.1: MCNP Output Data – Slab Man Included

Case	Source position	S/E	Shielding material	Source type	Tally 1	Tally 2	Tally 3	Tally 4	Tally 5	Tally 6	Tally 66	Tally 7	Tally 8	Tally 9	Tally 10	Tally 11	Tally 12	Tally 13	Tally 14	Tally 15	Tally 16	Tally 17	Tally 18	Tally 19	Tally 20
bx4d6	top	Exposed	Tungsten	Germanium	1.1E-03	5.1E-03	7.9E-04	4.0E-03	1.9E-03	3.0E-02	4.1E+03	7.8E-04	4.0E-03	2.2E-03	6.7E-04	1.1E-03	1.9E-02	6.6E-04	1.2E-02	1.7E-03	1.5E-02	6.6E-04	1.2E-02	2.2E-03	6.7E-04
bx4d7	upper right	Exposed	Tungsten	Germanium	1.6E-02	3.0E-02	1.5E-02	2.0E-02	1.6E-01	2.0E-01	4.5E+04	4.8E-02	1.3E+00	3.0E-01	1.7E-02	1.3E-02	3.1E-02	2.1E-02	2.6E-02	3.3E-01	3.9E-01	6.1E-02	3.9E-01	1.8E-01	1.5E-02
bx4d8	top	Shielded	Tungsten	Germanium	3.1E-04	8.6E-04	2.6E-04	6.2E-04	2.4E-03	4.4E-04	4.7E+01	2.7E-04	6.5E-04	6.4E-04	2.0E-04	3.6E-04	6.2E-03	2.4E-04	1.9E-03	4.3E-03	3.2E-03	2.5E-04	2.1E-03	7.9E-04	2.3E-04
bx4d9	upper right	Shielded	Tungsten	Germanium	5.7E-03	8.4E-03	2.1E-02	8.6E-03	1.8E-01	1.9E-01	4.3E+04	4.8E-02	1.3E+00	2.8E-01	1.4E-02	9.8E-03	2.8E-02	2.7E-02	2.4E-02	3.3E-01	3.8E-01	6.3E-02	4.0E-01	1.8E-01	1.4E-02
bx4d10	lower right	Exposed	Tungsten	Germanium	7.6E-03	2.3E-02	1.4E-03	1.3E-02	2.0E-03	2.3E-01	4.3E+03	6.1E-04	9.1E-03	5.0E-03	1.0E-03	1.1E-02	2.3E-03	1.4E-03	1.5E-03	1.9E-03	1.5E-02	7.1E-04	2.3E-03	7.4E-03	3.2E-03
bx4d11	lower right	Shielded	Tungsten	Germanium	1.0E-04	3.0E-04	2.2E-04	3.0E-04	3.3E-03	7.5E-03	7.6E+01	3.5E-04	1.1E-03	1.1E-03	2.8E-04	1.0E-04	6.5E-05	1.9E-04	7.4E-05	1.2E-03	9.5E-04	2.9E-04	6.0E-04	2.0E-03	5.7E-04
bx4d12	bottom	Exposed	Tungsten	Germanium	1.0E-03	3.5E-03	7.2E-04	2.9E-03	1.8E-03	7.6E-02	4.3E+03	7.1E-04	3.6E-03	1.7E-03	6.7E-04	1.2E-03	4.0E-02	8.7E-04	1.3E-02	1.9E-03	2.5E-03	8.9E-04	1.1E-02	2.1E-03	7.6E-04
bx4d13	bottom	Shielded	Tungsten	Germanium	3.6E-04	1.5E-03	2.9E-04	1.0E-03	4.0E-03	7.3E-03	5.1E+01	2.7E-04	1.1E-03	6.5E-04	2.4E-04	2.9E-04	3.3E-04	2.5E-04	3.0E-04	9.8E-04	1.2E-04	2.3E-04	3.3E-04	4.6E-04	2.5E-04
bx4d18	top	Exposed	Tungsten	Sodium	8.8E-03	3.0E-02	6.1E-03	2.5E-02	9.6E-03	9.0E-02	9.2E+03	6.0E-03	2.6E-02	1.8E-02	5.7E-03	7.9E-03	1.3E-01	4.6E-03	9.4E-02	1.1E-02	1.6E-01	4.6E-03	9.4E-02	1.9E-02	5.1E-03
bx4d19	top	Shielded	Tungsten	Sodium	7.1E-03	2.2E-02	5.6E-03	1.9E-02	1.8E-02	1.9E-02	1.7E+03	5.7E-03	2.0E-02	1.5E-02	4.9E-03	5.4E-03	7.1E-02	4.5E-03	3.5E-02	2.3E-02	4.7E-02	4.4E-03	3.1E-02	1.1E-02	3.8E-03
bx4d20	upper right	Exposed	Tungsten	Sodium	3.8E-02	7.2E-02	2.8E-02	5.0E-02	2.2E-01	4.4E-01	7.3E+04	5.6E-02	1.5E+00	3.7E-01	2.6E-02	3.2E-02	7.1E-02	4.0E-02	5.9E-02	3.8E-01	7.3E-01	8.7E-02	6.3E-01	2.9E-01	2.4E-02
bx4d21	upper right	Shielded	Tungsten	Sodium	1.2E-02	2.4E-02	3.2E-02	2.4E-02	2.4E-01	4.2E-01	6.9E+04	5.6E-02	1.4E+00	3.4E-01	1.9E-02	2.2E-02	6.6E-02	4.4E-02	5.6E-02	3.9E-01	7.2E-01	9.1E-02	6.2E-01	2.8E-01	1.9E-02
bx4d22	lower right	Exposed	Tungsten	Sodium	2.4E-02	7.0E-02	9.0E-03	4.1E-02	1.2E-02	6.7E-01	1.0E+04	4.0E-03	1.0E-01	5.4E-02	1.4E-02	2.7E-02	1.2E-02	8.3E-03	7.6E-03	1.1E-02	7.4E-02	5.4E-03	2.9E-02	6.2E-02	2.5E-02
bx4d23	lower right	Shielded	Tungsten	Sodium	2.8E-03	9.8E-03	5.1E-03	8.8E-03	2.1E-02	2.1E-01	2.2E+03	4.3E-03	2.2E-02	1.9E-02	4.2E-03	2.6E-03	2.0E-03	4.5E-03	1.9E-03	1.3E-02	2.6E-02	5.3E-03	1.7E-02	2.7E-02	7.1E-03
bx4d24	bottom	Exposed	Tungsten	Sodium	8.3E-03	4.5E-02	5.4E-03	3.5E-02	1.1E-02	4.6E-01	9.4E+03	5.3E-03	3.4E-02	1.6E-02	5.0E-03	9.2E-03	8.7E-02	6.3E-03	3.4E-02	9.2E-03	1.4E-02	6.2E-03	3.3E-02	1.5E-02	6.9E-03
bx4d25	bottom	Shielded	Tungsten	Sodium	6.4E-03	3.7E-02	5.2E-03	2.9E-02	2.2E-02	2.2E-01	1.7E+03	5.4E-03	3.0E-02	1.4E-02	3.7E-03	7.1E-03	9.6E-03	5.6E-03	9.5E-03	1.1E-02	3.8E-03	5.3E-03	9.1E-03	1.2E-02	5.4E-03
bx4d30	top	Exposed	Lead	Germanium	1.8E-03	7.4E-03	1.4E-03	6.0E-03	2.9E-03	3.0E-02	4.5E+03	1.3E-03	6.0E-03	3.8E-03	2.6E-03	1.8E-03	3.3E-02	1.1E-03	2.3E-02	2.9E-03	2.3E-02	1.1E-03	2.3E-02	4.1E-03	1.1E-03
bx4d31	top	Shielded	Lead	Germanium	9.5E-04	2.6E-03	8.7E-04	2.5E-03	4.9E-03	1.9E-03	2.2E+02	8.8E-04	2.5E-03	2.1E-03	7.0E-04	8.8E-04	1.4E-02	7.2E-04	5.0E-03	8.5E-03	7.4E-03	7.8E-04	5.0E-03	2.0E-03	6.7E-04
bx4d32	upper right	Exposed	Lead	Germanium	1.6E-02	3.0E-02	1.5E-02	2.1E-02	1.6E-01	2.0E-01	4.6E+04	4.8E-02	1.3E+00	3.0E-01	1.6E-02	1.3E-02	3.1E-02	2.2E-02	2.6E-02	3.3E-01	3.8E-01	6.4E-02	3.9E-01	1.8E-01	1.4E-02
bx4d33	upper right	Shielded	Lead	Germanium	5.9E-03	9.0E-03	2.1E-02	9.3E-03	1.9E-01	1.9E-01	4.4E+04	4.8E-02	1.3E+00	2.8E-01	1.5E-02	1.0E-02	2.8E-02	2.7E-02	2.4E-02	3.3E-01	3.8E-01	6.6E-02	4.0E-01	1.8E-01	1.4E-02
bx4d34	lower right	Exposed	Lead	Germanium	8.3E-03	2.3E-02	2.3E-03	1.3E-02	3.4E-03	2.9E-01	4.8E+03	1.0E-03	1.7E-02	8.5E-03	2.0E-03	1.2E-02	2.6E-03	2.2E-03	1.7E-03	3.0E-03	2.0E-02	1.2E-03	5.3E-03	1.4E-02	5.2E-03
bx4d35	lower right	Shielded	Lead	Germanium	3.6E-04	1.0E-03	8.6E-04	9.5E-04	7.8E-03	3.0E-02	3.3E+02	9.5E-04	3.3E-03	2.7E-03	5.8E-04	3.8E-04	2.3E-04	7.0E-04	2.5E-04	3.5E-03	3.4E-03	9.5E-04	2.3E-03	5.4E-03	1.5E-03
bx4d36	bottom	Exposed	Lead	Germanium	1.8E-03	9.8E-03	1.2E-03	6.0E-03	3.1E-03	1.2E-01	4.7E+03	1.2E-03	5.9E-03	3.4E-03	1.1E-03	2.0E-03	4.1E-02	1.4E-03	1.4E-02	2.7E-03	3.3E-03	1.4E-03	1.3E-02	3.5E-03	1.3E-03
bx4d37	bottom	Shielded	Lead	Germanium	9.8E-04	5.6E-03	9.4E-04	3.6E-03	8.4E-03	3.0E-02	2.7E+02	8.8E-04	4.2E-03	2.0E-03	6.3E-04	1.0E-03	1.2E-03	8.5E-04	1.1E-03	2.5E-03	4.5E-04	8.4E-04	1.3E-03	1.8E-03	7.3E-04
bx4d42	top	Exposed	Lead	Sodium	2.0E-02	6.5E-02	1.5E-02	5.6E-02	2.2E-02	1.2E-01	1.3E+04	1.5E-02	5.8E-02	4.2E-02	1.4E-02	1.6E-02	2.0E-01	1.1E-02	1.6E-01	2.0E-02	3.0E-01	1.1E-02	1.5E-01	3.7E-02	1.2E-02
bx4d43	top	Shielded	Lead	Sodium	1.8E-02	5.8E-02	1.6E-02	5.1E-02	3.0E-02	5.4E-02	4.9E+03	1.6E-02	5.3E-02	3.9E-02	1.3E-02	1.3E-02	1.3E-01	1.1E-02	8.4E-02	3.7E-02	1.5E-01	1.2E-02	8.0E-02	2.6E-02	8.9E-03
bx4d44	upper right	Exposed	Lead	Sodium	4.0E-02	8.3E-02	3.5E-02	5.9E-02	2.2E-01	4.5E-01	7.6E+04	6.1E-02	1.5E+00	4.0E-01	3.5E-02	3.4E-02	7.5E-02	4.4E-02	6.5E-02	3.8E-01	9.4E-01	9.3E-02	6.7E-01	3.0E-01	2.8E-02
bx4d45	upper right	Shielded	Lead	Sodium	1.6E-02	3.4E-02	3.7E-02	3.4E-02	2.5E-01	4.4E-01	7.1E+04	6.1E-02	1.5E+00	3.7E-01	2.6E-02	2.4E-02	7.1E-02	4.7E-02	6.0E-02	3.9E-01	8.9E-01	9.8E-02	6.4E-01	2.9E-01	2.4E-02
bx4d46	lower right	Exposed	Lead	Sodium	2.8E-02	8.0E-02	1.8E-02	5.4E-02	2.3E-02	1.0E+00	1.4E+04	9.5E-03	2.0E-01	8.2E-02	2.4E-02	2.9E-02	1.5E-02	1.6E-02	1.0E-02	2.4E-02	1.2E-01	1.3E-02	6.4E-02	1.0E-01	3.7E-02
bx4d47	lower right	Shielded	Lead	Sodium	7.0E-03	2.4E-02	1.3E-02	2.2E-02	3.5E-02	5.4E-01	5.9E+03	1.0E-02	8.9E-02	4.2E-02	1.0E-02	6.5E-03	5.1E-03	1.1E-02	4.9E-03	2.9E-02	6.8E-02	1.4E-02	4.5E-02	6.0E-02	1.6E-02
bx4d48	bottom	Exposed	Lead	Sodium	1.8E-02	1.0E-01	1.4E-02	8.8E-02	2.1E-02	9.2E-01	1.3E+04	1.3E-02	8.8E-02	4.0E-02	1.1E-02	2.0E-02	1.0E-01	1.5E-02	4.9E-02	2.0E-02	2.3E-02	1.5E-02	4.9E-02	3.5E-02	1.5E-02
bx4d49	bottom	Shielded	Lead	Sodium	1.6E-02	1.0E-01	1.4E-02	7.9E-02	3.6E-02	6.4E-01	4.9E+03	1.4E-02	7.6E-02	3.7E-02	1.2E-02	1.9E-02	2.6E-02	1.4E-02	2.4E-02	2.5E-02	1.1E-02	1.5E-02	2.6E-02	3.2E-02	1.4E-02

Appendix B.2: MCNP Output Data – Slab Man Not Included

Name	Source position	S/E	Shielding material	Source type	Tally 1	Tally 2	Tally 3	Tally 4	Tally 5	Tally 6	Tally 66	Tally 7	Tally 8	Tally 9	Tally 10	Tally 11	Tally 12	Tally 13	Tally 14	Tally 15	Tally 16	Tally 17	Tally 18	Tally 19	Tally 20
voidd6	top	Exposed	Tungsten	Germanium	5.8E-03	1.3E-02	3.7E-03	8.2E-02	6.3E-03	5.6E-02	3.2E+04	3.6E-03	7.3E-02	3.6E-03	1.3E-02	3.5E-03	8.8E-03	3.4E-03	1.6E-02	5.8E-03	3.2E-01	3.3E-03	1.5E-02	5.0E-03	8.6E-03
voidd7	upper right	Exposed	Tungsten	Germanium	2.9E-01	2.9E-01	5.0E-01	1.9E-01	1.5E+00	6.1E-01	7.4E+05	7.7E-01	1.0E+00	7.2E-01	1.9E+00	1.7E-01	3.4E-01	5.4E-01	5.6E-01	2.0E+00	2.2E+01	2.6E-01	3.3E-01	7.0E-02	1.7E-01
voidd8	top	Shielded	Tungsten	Germanium	1.1E-03	2.2E-03	1.3E-03	2.1E-03	4.8E-03	2.8E-03	4.3E+02	1.3E-03	2.0E-03	1.1E-03	2.2E-03	1.2E-03	3.4E-03	1.5E-03	6.2E-03	2.2E-02	3.2E-02	1.5E-03	6.4E-03	1.5E-03	3.5E-03
voidd9	upper right	Shielded	Tungsten	Germanium	1.2E-01	2.2E-01	5.0E-01	1.5E-01	1.5E+00	5.6E-01	7.2E+05	7.7E-01	9.8E-01	7.9E-01	1.9E+00	1.3E-01	2.8E-01	5.4E-01	4.8E-01	2.1E+00	2.2E+01	2.6E-01	2.9E-01	7.5E-02	1.6E-01
voidd10	lower right	Exposed	Tungsten	Germanium	9.7E-02	1.9E-02	7.4E-03	2.8E-02	5.9E-03	2.0E-02	6.9E+04	2.2E-03	2.1E-02	5.5E-03	1.8E-02	3.2E-01	5.2E-01	1.0E-02	8.0E-01	7.7E-03	2.5E+00	2.7E-03	9.8E-02	1.1E-02	5.4E-02
voidd11	lower right	Shielded	Tungsten	Germanium	7.2E-04	1.2E-03	1.3E-03	3.7E-03	1.4E-02	8.7E-03	7.3E+02	1.6E-03	3.9E-03	7.7E-04	2.6E-03	1.3E-03	2.8E-03	1.6E-03	8.0E-03	1.6E-02	2.9E-02	1.9E-03	1.2E-02	5.2E-03	1.1E-02
voidd12	bottom	Exposed	Tungsten	Germanium	4.7E-03	1.6E-02	3.4E-03	9.3E-02	5.1E-03	5.0E-02	3.3E+04	3.3E-03	9.3E-02	5.0E-03	1.6E-02	3.7E-03	1.0E-02	3.7E-03	1.6E-02	5.4E-03	1.2E+00	3.7E-03	1.6E-02	3.7E-03	9.5E-03
voidd13	bottom	Shielded	Tungsten	Germanium	1.5E-03	4.4E-03	1.6E-03	1.4E-02	2.3E-02	1.1E-02	4.5E+02	1.6E-03	1.4E-02	1.9E-03	5.0E-03	1.3E-03	3.6E-03	1.7E-03	5.3E-03	1.4E-02	1.7E-02	1.7E-03	5.3E-03	1.4E-03	3.5E-03
voidd18	top	Exposed	Tungsten	Sodium	3.2E-02	7.4E-02	3.1E-02	2.3E-01	4.2E-02	2.4E-01	6.6E+04	3.2E-02	2.1E-01	3.3E-02	7.4E-02	2.7E-02	9.1E-02	3.0E-02	1.9E-01	5.0E-02	2.2E+00	2.9E-02	1.9E-01	2.7E-02	9.1E-02
voidd19	top	Shielded	Tungsten	Sodium	2.7E-02	5.4E-02	2.8E-02	6.1E-02	5.1E-02	6.4E-02	1.2E+04	2.8E-02	6.0E-02	2.8E-02	5.6E-02	2.2E-02	7.8E-02	2.9E-02	1.6E-01	1.2E-01	9.5E-01	2.9E-02	1.6E-01	2.3E-02	7.9E-02
voidd20	upper right	Exposed	Tungsten	Sodium	4.7E-01	5.5E-01	6.1E-01	3.3E-01	1.7E+00	1.6E+00	8.1E+05	8.4E-01	1.7E+00	8.6E-01	2.2E+00	3.1E-01	6.6E-01	6.5E-01	1.1E+00	2.3E+00	2.7E+01	2.9E-01	6.8E-01	1.2E-01	3.5E-01
voidd21	upper right	Shielded	Tungsten	Sodium	2.1E-01	4.0E-01	5.9E-01	2.4E-01	1.7E+00	1.2E+00	7.7E+05	8.5E-01	1.6E+00	8.6E-01	2.1E+00	2.2E-01	5.1E-01	6.4E-01	9.6E-01	2.3E+00	2.7E+01	2.9E-01	4.1E-01	9.1E-02	2.2E-01
voidd22	lower right	Exposed	Tungsten	Sodium	2.2E-01	9.2E-02	5.1E-02	1.9E-01	4.9E-02	4.0E-01	1.1E+05	1.8E-02	3.0E-01	7.5E-02	2.3E-01	6.7E-01	8.3E-01	6.7E-02	1.2E+00	5.4E-02	3.9E+00	2.3E-02	9.0E-01	1.1E-01	4.5E-01
voidd23	lower right	Shielded	Tungsten	Sodium	2.4E-02	3.1E-02	3.0E-02	9.4E-02	9.3E-02	3.3E-01	1.8E+04	2.1E-02	6.6E-02	1.5E-02	5.3E-02	3.1E-02	6.8E-02	3.8E-02	1.9E-01	1.0E-01	7.4E-01	2.6E-02	2.5E-01	2.7E-02	1.3E-01
voidd24	bottom	Exposed	Tungsten	Sodium	3.3E-02	1.3E-01	2.6E-02	6.8E-01	4.9E-02	6.7E-01	6.8E+04	2.6E-02	6.8E-01	3.2E-02	1.3E-01	3.4E-02	9.7E-02	3.4E-02	1.7E-01	4.5E-02	2.3E+00	3.4E-02	1.6E-01	3.5E-02	9.8E-02
voidd25	bottom	Shielded	Tungsten	Sodium	2.1E-02	5.7E-02	2.5E-02	1.9E-01	1.2E-01	2.0E-01	1.2E+04	2.5E-02	1.9E-01	2.1E-02	5.7E-02	2.9E-02	8.4E-02	3.3E-02	1.4E-01	9.2E-02	4.7E-01	3.3E-02	1.5E-01	2.9E-02	8.4E-02
voidd30	top	Exposed	Lead	Germanium	6.9E-03	1.9E-02	7.0E-03	9.4E-02	9.9E-03	6.5E-02	3.5E+04	6.6E-03	1.0E-01	6.7E-03	1.9E-02	6.3E-03	1.7E-02	6.2E-03	3.3E-02	1.3E-02	5.8E-01	6.1E-03	3.1E-02	5.9E-03	1.7E-02
voidd31	top	Shielded	Lead	Germanium	3.8E-03	7.6E-03	4.4E-03	7.8E-03	1.3E-02	6.5E-03	1.8E+03	4.6E-03	7.6E-03	4.2E-03	7.7E-03	3.6E-03	1.1E-02	4.9E-03	2.1E-02	4.3E-02	1.4E-01	5.0E-03	2.2E-02	3.5E-03	1.1E-02
voidd32	upper right	Exposed	Lead	Germanium	3.3E-01	3.0E-01	5.0E-01	1.9E-01	1.5E+00	6.3E-01	7.4E+05	7.7E-01	1.1E+00	7.1E-01	1.9E+00	1.6E-01	3.4E-01	5.4E-01	5.6E-01	2.0E+00	2.2E+01	2.6E-01	3.6E-01	7.2E-02	1.8E-01
voidd33	upper right	Shielded	Lead	Germanium	1.2E-01	2.3E-01	5.0E-01	1.6E-01	1.5E+00	5.6E-01	7.2E+05	7.7E-01	9.8E-01	7.6E-01	1.9E+00	1.3E-01	2.8E-01	5.4E-01	4.8E-01	2.1E+00	2.2E+01	2.7E-01	3.0E-01	7.1E-02	1.6E-01
voidd34	lower right	Exposed	Lead	Germanium	1.0E-01	2.7E-02	1.3E-02	5.0E-02	1.2E-02	5.8E-02	7.3E+04	4.0E-03	4.3E-02	1.1E-02	3.3E-02	3.3E-01	5.4E-01	1.8E-02	8.2E-01	1.5E-02	2.6E+00	5.1E-03	1.9E-01	1.8E-02	8.6E-02
voidd35	lower right	Shielded	Lead	Germanium	2.6E-03	4.6E-03	4.8E-03	1.4E-02	3.2E-02	3.4E-02	2.9E+03	4.6E-03	1.0E-02	2.5E-03	8.0E-03	5.0E-03	1.1E-02	6.0E-03	3.0E-02	3.5E-02	1.2E-01	5.5E-03	3.9E-02	1.5E-02	2.5E-02
voidd36	bottom	Exposed	Lead	Germanium	8.4E-03	3.0E-02	6.0E-03	1.7E-01	1.1E-02	9.4E-02	3.6E+04	5.9E-03	1.7E-01	1.0E-02	3.0E-02	6.7E-03	1.9E-02	7.2E-03	3.1E-02	1.1E-02	1.2E+00	7.1E-03	3.1E-02	7.1E-03	1.9E-02
voidd37	bottom	Shielded	Lead	Germanium	3.6E-03	1.1E-02	4.7E-03	3.4E-02	4.5E-02	3.1E-02	1.8E+03	4.7E-03	3.6E-02	3.8E-03	1.1E-02	4.5E-03	1.2E-02	5.4E-03	2.0E-02	3.2E-02	6.7E-02	5.5E-03	2.0E-02	4.6E-03	1.2E-02
voidd42	top	Exposed	Lead	Sodium	7.5E-02	1.6E-01	7.8E-02	3.3E-01	1.0E-01	3.7E-01	9.0E+04	7.8E-02	3.2E-01	7.6E-02	1.6E-01	6.4E-02	2.1E-01	7.7E-02	4.6E-01	1.0E-01	4.3E+00	7.8E-02	4.6E-01	6.8E-02	2.1E-01
voidd43	top	Shielded	Lead	Sodium	7.2E-02	1.4E-01	7.8E-02	1.6E-01	1.2E-01	2.2E-01	3.4E+04	7.8E-02	1.6E-01	7.0E-02	1.4E-01	5.9E-02	2.0E-01	8.0E-02	4.2E-01	1.9E-01	2.8E+00	8.0E-02	4.2E-01	5.9E-02	2.0E-01
voidd44	upper right	Exposed	Lead	Sodium	5.0E-01	5.8E-01	6.3E-01	3.6E-01	1.7E+00	1.4E+00	8.2E+05	8.6E-01	1.7E+00	9.1E-01	2.2E+00	3.2E-01	6.9E-01	6.8E-01	1.2E+00	2.3E+00	2.8E+01	3.0E-01	9.3E-01	1.4E-01	4.1E-01
voidd45	upper right	Shielded	Lead	Sodium	2.4E-01	4.3E-01	6.2E-01	2.8E-01	1.8E+00	1.3E+00	7.8E+05	8.7E-01	1.6E+00	8.7E-01	2.1E+00	2.4E-01	5.4E-01	6.6E-01	1.0E+00	2.4E+00	2.7E+01	3.1E-01	6.1E-01	1.0E-01	2.9E-01
voidd46	lower right	Exposed	Lead	Sodium	2.3E-01	1.5E-01	1.0E-01	3.6E-01	1.2E-01	8.5E-01	1.4E+05	4.6E-02	5.8E-01	1.1E-01	3.6E-01	5.3E-01	9.0E-01	1.3E-01	1.4E+00	1.2E-01	4.9E+00	5.9E-02	1.6E+00	1.5E-01	6.2E-01
voidd47	lower right	Shielded	Lead	Sodium	5.0E-02	7.8E-02	7.6E-02	2.3E-01	1.7E-01	8.2E-01	4.8E+04	5.3E-02	2.3E-01	4.4E-02	1.5E-01	7.9E-02	1.7E-01	9.6E-02	4.4E-01	1.7E-01	1.9E+00	6.8E-02	7.9E-01	6.3E-02	3.0E-01
voidd48	bottom	Exposed	Lead	Sodium	6.5E-02	2.3E-01	6.1E-02	1.1E+00	1.0E-01	1.4E+00	9.1E+04	6.1E-02	1.1E+00	6.2E-02	2.2E-01	7.6E-02	2.3E-01	8.6E-02	4.1E-01	1.0E-01	3.2E+00	8.7E-02	3.9E-01	7.9E-02	2.3E-01
voidd49	bottom	Shielded	Lead	Sodium	5.4E-02	1.5E-01	6.5E-02	5.3E-01	1.9E-01	6.2E-01	3.4E+04	6.4E-02	5.1E-01	4.7E-02	1.3E-01	7.1E-02	2.1E-01	9.0E-02	3.9E-01	1.6E-01	1.3E+00	8.9E-02	4.2E-01	7.3E-02	2.2E-01

Appendix B.3: MCNP Output Standard Deviation Data – Slab Man Not Included

Name	Source position	S/E	Shielding material	Source type	SD 1	SD 2	SD 3	SD 4	SD 5	SD 6	SD 66	SD 7	SD 8	SD 9	SD 10	SD 11	SD 12	SD 13	SD 14	SD 15	SD 16	SD 17	SD 18	SD 19	SD 20
voidd6	top	Exposed	Tungsten	Germanium	3.0E-01	6.1E-03	6.0E-03	9.5E-03	2.3E-02	4.0E-02	2.5E-03	7.3E-03	9.7E-03	1.3E-02	8.0E-03	3.7E-02	1.5E-02	5.4E-03	2.4E-02	8.1E-03	1.1E-02	1.1E-02	9.4E-03	2.4E-01	1.6E-02
voidd7	upper right	Exposed	Tungsten	Germanium	2.3E-02	4.6E-03	1.2E-03	9.7E-03	1.0E-03	6.2E-02	2.1E-03	1.1E-03	2.6E-03	8.2E-03	9.0E-04	4.6E-02	1.0E-02	1.1E-03	7.5E-03	9.0E-04	9.0E-04	2.2E-03	5.8E-03	8.6E-03	3.2E-03
voidd8	top	Shielded	Tungsten	Germanium	2.1E-02	4.3E-02	5.0E-02	2.4E-02	8.8E-03	2.1E-01	2.7E-02	1.4E-02	2.3E-02	1.7E-02	1.5E-02	8.7E-02	2.2E-02	1.3E-02	2.9E-02	9.4E-03	2.4E-02	1.7E-02	2.4E-02	2.8E-01	4.1E-02
voidd9	upper right	Shielded	Tungsten	Germanium	4.8E-02	3.1E-03	7.0E-04	4.1E-03	5.0E-04	2.9E-02	1.2E-03	6.0E-04	3.4E-03	3.9E-02	5.0E-04	2.6E-02	4.5E-03	6.0E-04	8.9E-03	5.0E-04	5.0E-04	1.2E-03	3.0E-03	3.6E-02	3.6E-03
voidd10	lower right	Exposed	Tungsten	Germanium	7.2E-02	7.2E-03	6.4E-03	1.2E-02	1.4E-02	4.3E-02	2.9E-03	8.9E-03	1.6E-02	2.0E-02	1.3E-02	1.0E-02	1.0E-03	4.7E-03	8.0E-04	6.4E-03	6.3E-03	6.4E-03	8.2E-03	9.7E-03	5.9E-03
voidd11	lower right	Shielded	Tungsten	Germanium	2.1E-02	1.5E-02	1.3E-02	1.9E-02	1.1E-02	8.7E-02	2.3E-02	2.4E-02	1.6E-01	2.8E-02	2.5E-02	3.6E-02	1.5E-02	1.1E-02	1.2E-02	1.1E-02	1.3E-02	1.9E-02	1.6E-02	6.0E-01	1.9E-02
voidd12	bottom	Exposed	Tungsten	Germanium	1.8E-02	8.8E-03	7.7E-03	5.9E-03	1.9E-02	3.4E-02	2.3E-03	6.8E-03	6.3E-03	4.1E-02	6.6E-03	2.8E-02	8.7E-03	5.7E-03	8.7E-03	6.4E-03	1.3E-03	7.8E-03	1.6E-02	4.5E-02	5.5E-03
voidd13	bottom	Shielded	Tungsten	Germanium	2.5E-02	1.1E-02	1.5E-02	9.9E-03	1.1E-02	2.1E-02	2.4E-02	1.4E-02	8.2E-03	1.6E-01	6.2E-02	1.9E-02	1.5E-02	1.7E-02	2.0E-02	8.9E-03	4.2E-02	1.0E-02	1.3E-02	8.3E-02	8.8E-03
voidd18	top	Exposed	Tungsten	Sodium	9.7E-03	6.3E-03	9.1E-03	5.2E-03	1.6E-02	4.6E-02	3.1E-03	1.2E-02	6.0E-03	3.0E-02	9.8E-03	1.2E-02	1.3E-02	1.7E-02	6.8E-03	1.0E-02	1.5E-02	7.2E-03	7.9E-03	1.4E-02	1.3E-02
voidd19	top	Shielded	Tungsten	Sodium	2.4E-02	9.4E-03	6.8E-03	1.0E-02	6.9E-03	4.3E-02	7.1E-03	1.2E-02	7.8E-03	3.0E-02	3.6E-02	1.2E-02	7.3E-03	8.3E-03	1.2E-02	4.4E-03	2.4E-02	6.3E-03	7.8E-03	1.3E-02	1.2E-02
voidd20	upper right	Exposed	Tungsten	Sodium	1.4E-02	6.2E-03	1.5E-03	8.5E-03	7.0E-04	1.2E-01	1.7E-03	8.0E-04	3.1E-03	1.8E-02	2.0E-03	2.3E-02	4.5E-03	2.9E-03	3.6E-03	7.0E-04	8.0E-04	1.9E-03	4.0E-03	7.5E-02	1.5E-02
voidd21	upper right	Shielded	Tungsten	Sodium	1.7E-02	2.6E-03	8.0E-04	6.3E-03	6.0E-04	3.5E-02	1.3E-03	6.0E-04	2.2E-03	5.3E-02	6.0E-04	2.9E-02	2.3E-03	1.1E-03	2.2E-02	7.0E-04	7.0E-04	1.4E-03	4.7E-03	4.1E-02	4.3E-03
voidd22	lower right	Exposed	Tungsten	Sodium	3.9E-02	6.2E-03	5.8E-03	3.4E-03	6.3E-03	5.7E-02	2.5E-03	4.8E-03	1.9E-02	3.2E-02	8.3E-03	2.0E-01	1.5E-03	6.4E-03	2.3E-03	1.6E-02	1.2E-03	5.0E-03	7.3E-03	7.2E-03	4.6E-03
voidd23	lower right	Shielded	Tungsten	Sodium	1.7E-01	5.3E-03	7.9E-03	7.2E-03	3.2E-03	9.7E-02	5.7E-03	9.9E-03	1.3E-02	2.6E-02	7.3E-03	1.0E-02	4.9E-03	5.0E-03	9.2E-03	7.4E-03	5.9E-03	5.6E-03	1.8E-02	7.7E-02	5.7E-03
voidd24	bottom	Exposed	Tungsten	Sodium	3.5E-02	4.6E-03	1.0E-02	3.0E-03	6.1E-03	2.2E-02	2.5E-03	1.1E-02	4.2E-03	2.8E-02	4.6E-03	2.0E-02	5.6E-03	8.6E-03	5.5E-03	7.7E-03	1.5E-03	5.4E-03	8.8E-03	2.7E-02	9.2E-03
voidd25	bottom	Shielded	Tungsten	Sodium	4.4E-02	6.1E-03	9.8E-03	7.6E-03	3.7E-03	5.0E-02	5.6E-03	8.1E-03	5.7E-03	5.5E-02	7.3E-03	2.9E-02	6.6E-03	1.1E-02	4.9E-03	3.7E-03	6.4E-03	8.7E-03	3.0E-02	2.7E-02	1.1E-02
voidd30	top	Exposed	Lead	Germanium	4.6E-02	1.2E-02	3.8E-02	1.1E-02	9.7E-03	7.1E-02	5.9E-03	1.2E-02	1.3E-01	4.1E-02	1.1E-02	5.8E-02	1.2E-02	1.0E-02	1.7E-02	5.9E-02	1.1E-02	1.2E-02	1.7E-02	3.2E-02	1.2E-02
voidd31	top	Shielded	Lead	Germanium	1.9E-02	1.8E-02	8.7E-03	1.9E-02	9.2E-03	2.2E-02	1.5E-02	3.0E-02	1.3E-02	8.4E-02	1.1E-02	5.3E-02	9.6E-03	8.4E-03	1.3E-02	7.6E-03	2.5E-02	1.2E-02	1.5E-02	2.1E-02	1.0E-02
voidd32	upper right	Exposed	Lead	Germanium	5.8E-02	8.5E-03	1.5E-03	8.5E-03	1.2E-03	6.1E-02	2.6E-03	1.5E-03	3.8E-03	5.4E-03	1.1E-03	2.1E-02	1.3E-02	1.4E-03	7.0E-03	1.1E-03	1.1E-03	2.6E-03	1.0E-02	6.7E-03	3.9E-03
voidd33	upper right	Shielded	Lead	Germanium	9.8E-03	3.3E-03	7.0E-04	4.1E-03	5.0E-04	3.1E-02	1.2E-03	6.0E-04	6.8E-03	3.6E-02	5.0E-04	1.7E-02	4.1E-03	6.0E-04	7.9E-03	5.0E-04	5.0E-04	1.2E-03	5.3E-03	1.2E-02	2.1E-03
voidd34	lower right	Exposed	Lead	Germanium	4.4E-02	8.0E-03	1.1E-02	5.6E-03	1.7E-02	4.1E-02	2.7E-03	6.9E-03	1.7E-02	7.7E-02	9.1E-03	2.1E-02	1.1E-03	4.7E-03	8.0E-04	1.0E-02	5.5E-03	8.2E-03	6.2E-03	2.2E-02	5.5E-03
voidd35	lower right	Shielded	Lead	Germanium	2.0E-02	1.7E-02	8.6E-03	2.2E-02	2.5E-02	8.2E-02	1.2E-02	1.4E-02	1.7E-02	5.7E-02	4.4E-02	3.4E-02	1.9E-02	6.9E-03	1.4E-02	1.3E-02	2.6E-02	1.6E-02	2.2E-02	6.9E-01	9.5E-03
voidd36	bottom	Exposed	Lead	Germanium	6.1E-02	5.7E-03	5.3E-03	6.3E-03	7.0E-03	3.6E-02	2.4E-03	5.9E-03	5.0E-03	1.4E-01	5.4E-03	9.6E-03	6.4E-03	8.1E-03	7.9E-03	1.9E-02	1.6E-03	1.2E-02	8.5E-03	4.1E-02	9.5E-03
voidd37	bottom	Shielded	Lead	Germanium	1.5E-02	1.2E-02	2.2E-02	1.0E-02	1.1E-02	2.7E-02	1.4E-02	1.5E-02	1.4E-02	2.7E-02	9.2E-03	5.9E-02	8.2E-03	7.2E-03	1.8E-02	9.8E-03	9.9E-03	7.9E-03	9.8E-03	6.8E-02	9.2E-03
voidd42	top	Exposed	Lead	Sodium	2.2E-02	4.7E-03	3.7E-03	4.8E-03	1.4E-02	5.1E-02	2.4E-03	8.4E-03	9.4E-03	1.8E-02	3.8E-03	1.2E-02	7.3E-03	5.9E-03	5.2E-03	9.8E-03	5.3E-03	7.5E-03	4.1E-03	4.7E-02	5.8E-03
voidd43	top	Shielded	Lead	Sodium	2.1E-02	4.6E-03	6.6E-03	7.5E-03	6.3E-03	1.7E-01	3.9E-03	6.7E-03	6.5E-03	1.3E-02	8.1E-03	1.1E-02	7.5E-03	7.5E-03	6.2E-03	3.1E-03	1.0E-02	6.6E-03	6.8E-03	1.1E-02	5.6E-03
voidd44	upper right	Exposed	Lead	Sodium	2.8E-02	4.2E-03	1.0E-03	8.7E-03	6.0E-04	3.7E-02	1.1E-03	6.0E-04	1.9E-03	3.3E-02	5.0E-04	1.5E-02	4.0E-03	7.0E-04	3.3E-03	5.0E-04	6.0E-04	1.2E-03	6.0E-03	8.3E-02	3.9E-03
voidd45	upper right	Shielded	Lead	Sodium	1.2E-02	2.3E-03	1.3E-03	4.5E-03	5.0E-04	6.5E-02	1.1E-03	9.0E-04	3.6E-03	3.7E-02	5.0E-04	3.4E-02	3.8E-03	7.0E-04	2.6E-03	7.0E-04	9.0E-04	1.5E-03	6.8E-03	2.5E-02	3.1E-03
voidd46	lower right	Exposed	Lead	Sodium	6.0E-03	6.4E-03	4.0E-03	7.9E-03	9.2E-03	1.6E-02	2.3E-03	6.5E-03	1.4E-02	1.5E-02	5.3E-03	4.4E-02	9.0E-04	4.2E-03	2.6E-03	4.6E-03	2.8E-03	9.0E-03	4.4E-03	2.1E-02	3.3E-03
voidd47	lower right	Shielded	Lead	Sodium	2.0E-02	6.9E-03	4.9E-03	8.1E-03	4.8E-03	5.7E-02	3.7E-03	1.9E-02	8.2E-03	2.2E-02	7.7E-03	2.4E-02	4.7E-03	5.8E-03	5.4E-03	1.4E-02	4.5E-03	7.4E-03	1.5E-02	3.1E-02	6.8E-03
voidd48	bottom	Exposed	Lead	Sodium	8.8E-02	5.9E-03	6.4E-03	3.4E-03	1.0E-02	3.2E-02	2.8E-03	5.4E-03	5.1E-03	3.0E-02	6.6E-03	1.4E-02	6.3E-03	3.6E-03	1.5E-02	5.4E-03	4.4E-03	7.7E-03	4.6E-03	3.7E-02	7.6E-03
voidd49	bottom	Shielded	Lead	Sodium	1.4E-01	1.4E-01	9.5E-03	1.8E-02	5.3E-03	2.2E-02	7.0E-03	6.3E-03	4.9E-03	1.8E-02	1.4E-02	1.4E-02	5.8E-03	9.0E-03	1.5E-02	1.2E-02	5.2E-03	5.7E-03	8.1E-02	3.4E-02	1.1E-02

Appendix B.4: MCNP Output Standard Deviation Data – Slab Man Included

Case	Source position	S/E	Shielding material	Source type	SD 1	SD 2	SD 3	SD 4	SD 5	SD 6	SD 66	SD 7	SD 8	SD 9	SD 10	SD 11	SD 12	SD 13	SD 14	SD 15	SD 16	SD 17	SD 18	SD 19	SD 20
bx4d6	top	Exposed	Tungsten	Germanium	1.3E-02	3.6E-02	2.6E-02	1.7E-02	7.7E-02	2.7E-02	9.0E-03	1.8E-02	2.1E-02	2.5E-02	3.9E-02	1.6E-02	1.9E-02	1.6E-02	2.3E-02	1.9E-02	4.6E-02	1.6E-02	1.5E-02	2.5E-02	1.9E-02
bx4d7	upper right	Exposed	Tungsten	Germanium	6.2E-03	4.0E-03	3.2E-03	6.1E-03	1.6E-03	7.2E-03	2.4E-03	2.3E-03	1.0E-03	1.3E-03	1.1E-01	6.9E-03	1.1E-02	2.2E-03	1.2E-02	1.0E-03	4.5E-02	1.7E-03	1.3E-03	2.4E-03	7.1E-02
bx4d8	top	Shielded	Tungsten	Germanium	5.5E-02	1.8E-01	3.6E-02	4.9E-02	3.1E-02	1.2E-01	9.8E-02	5.7E-02	3.3E-02	7.9E-02	2.8E-02	2.5E-02	2.1E-02	2.9E-02	2.4E-02	4.2E-02	6.9E-02	4.3E-02	2.8E-02	2.8E-02	2.3E-02
bx4d9	upper right	Shielded	Tungsten	Germanium	4.9E-03	9.2E-03	2.7E-03	8.5E-03	1.7E-03	7.0E-03	2.4E-03	2.5E-03	1.0E-03	1.4E-03	2.7E-02	9.9E-03	1.1E-02	2.5E-03	9.4E-03	1.1E-03	5.4E-02	1.9E-03	1.3E-03	1.2E-03	5.9E-02
bx4d10	lower right	Exposed	Tungsten	Germanium	7.2E-03	1.7E-02	2.7E-02	1.7E-02	1.2E-02	6.2E-03	9.3E-03	1.4E-02	1.4E-02	3.1E-02	3.9E-02	3.0E-03	2.0E-02	1.5E-02	3.6E-02	1.2E-02	2.2E-02	1.5E-02	3.5E-02	2.6E-02	2.3E-02
bx4d11	lower right	Shielded	Tungsten	Germanium	4.3E-02	9.8E-02	3.1E-02	1.0E-01	1.5E-02	3.1E-02	8.0E-02	9.1E-02	5.9E-02	3.1E-02	2.7E-01	4.5E-02	5.5E-02	3.3E-02	5.3E-02	1.5E-02	6.3E-02	4.5E-02	5.4E-02	5.0E-02	4.1E-02
bx4d12	bottom	Exposed	Tungsten	Germanium	1.3E-02	2.3E-02	2.0E-02	3.5E-02	1.7E-02	2.0E-02	8.8E-03	1.4E-02	1.7E-01	2.2E-02	2.2E-02	1.3E-02	2.0E-02	2.3E-02	1.6E-02	1.3E-02	4.5E-02	4.7E-02	1.8E-02	1.7E-02	1.9E-02
bx4d13	bottom	Shielded	Tungsten	Germanium	3.8E-02	5.8E-02	3.9E-02	4.4E-02	3.0E-02	5.4E-02	1.0E-01	2.4E-02	5.2E-02	3.1E-02	5.2E-02	2.4E-02	8.6E-02	3.6E-02	5.0E-02	2.6E-02	6.0E-02	2.6E-02	8.4E-02	2.4E-02	1.0E-01
bx4d18	top	Exposed	Tungsten	Sodium	2.0E-02	1.1E-02	1.2E-02	1.3E-02	1.3E-02	2.5E-02	9.4E-03	1.0E-02	1.7E-02	1.6E-02	1.3E-02	1.1E-02	7.4E-03	1.0E-02	4.1E-02	3.7E-02	3.1E-02	1.1E-02	2.1E-02	1.6E-02	3.3E-02
bx4d19	top	Shielded	Tungsten	Sodium	1.3E-02	1.1E-02	9.2E-03	1.4E-02	9.3E-02	5.0E-02	2.1E-02	1.6E-02	2.8E-02	1.4E-02	2.1E-02	1.4E-02	1.2E-01	2.1E-02	1.4E-01	9.5E-03	5.6E-02	1.6E-02	4.5E-02	3.3E-02	7.6E-02
bx4d20	upper right	Exposed	Tungsten	Sodium	4.0E-03	7.4E-03	2.8E-03	1.0E-02	1.6E-03	7.4E-03	2.7E-03	3.5E-03	9.0E-04	2.2E-03	2.1E-02	5.8E-03	1.1E-02	2.4E-03	1.5E-02	1.0E-03	1.6E-02	1.5E-03	1.4E-03	2.2E-03	3.7E-02
bx4d21	upper right	Shielded	Tungsten	Sodium	5.2E-03	8.4E-03	5.9E-03	7.7E-03	1.6E-03	7.2E-03	2.8E-03	2.8E-03	2.1E-03	2.3E-03	1.4E-02	6.2E-03	1.0E-02	2.4E-03	9.6E-03	9.0E-04	1.5E-02	5.4E-03	2.1E-03	2.3E-03	2.3E-02
bx4d22	lower right	Exposed	Tungsten	Sodium	4.0E-03	1.5E-02	2.0E-02	1.2E-02	2.1E-02	6.2E-03	8.8E-03	1.4E-02	8.7E-03	4.7E-03	9.9E-02	4.8E-03	1.7E-02	1.0E-02	4.7E-02	1.7E-02	5.1E-02	2.3E-02	2.6E-02	1.2E-02	3.2E-02
bx4d23	lower right	Shielded	Tungsten	Sodium	2.4E-02	4.8E-02	1.2E-02	2.6E-02	1.2E-02	3.4E-02	2.0E-02	1.0E-02	1.7E-02	5.0E-02	4.8E-02	1.3E-02	2.9E-02	2.3E-02	2.2E-02	1.3E-02	2.1E-02	5.0E-02	3.4E-02	1.0E-02	2.1E-02
bx4d24	bottom	Exposed	Tungsten	Sodium	2.0E-02	3.2E-02	1.0E-02	1.3E-02	2.2E-02	4.8E-02	8.7E-03	1.1E-02	1.2E-02	1.1E-02	6.2E-02	9.4E-03	1.0E-02	1.7E-02	1.2E-02	1.3E-02	2.6E-02	1.2E-02	1.7E-02	1.1E-02	9.3E-02
bx4d25	bottom	Shielded	Tungsten	Sodium	9.4E-03	1.5E-02	1.3E-02	1.8E-02	8.8E-03	1.7E-02	2.2E-02	2.2E-02	2.4E-02	2.1E-02	1.7E-02	8.7E-03	2.6E-02	4.9E-02	3.2E-02	1.3E-02	4.2E-02	1.6E-02	2.5E-02	1.5E-02	6.8E-02
bx4d30	top	Exposed	Lead	Germanium	1.4E-02	2.8E-02	6.4E-02	1.9E-02	6.1E-02	3.0E-02	9.1E-03	1.6E-02	2.1E-02	1.3E-02	5.5E-01	1.9E-02	1.0E-02	1.4E-02	1.3E-02	3.6E-02	2.4E-02	4.7E-02	1.5E-02	2.0E-02	2.1E-02
bx4d31	top	Shielded	Lead	Germanium	2.0E-02	2.4E-02	3.0E-02	1.2E-01	1.2E-02	8.2E-02	4.8E-02	2.0E-02	3.2E-02	2.3E-02	3.6E-02	2.0E-02	2.1E-02	1.6E-02	3.3E-02	4.3E-02	3.8E-02	3.0E-02	2.0E-02	2.0E-02	5.9E-02
bx4d32	upper right	Exposed	Lead	Germanium	8.2E-03	4.0E-03	3.9E-03	4.7E-03	1.7E-03	7.3E-03	2.4E-03	2.4E-03	1.0E-03	2.9E-03	2.8E-02	5.8E-03	1.2E-02	3.9E-03	9.2E-03	1.0E-03	2.7E-02	1.9E-03	1.5E-03	1.4E-03	3.4E-02
bx4d33	upper right	Shielded	Lead	Germanium	5.2E-03	9.9E-03	2.7E-03	1.0E-02	1.6E-03	7.7E-03	2.5E-03	2.6E-03	1.0E-03	1.4E-03	2.8E-02	1.1E-02	1.2E-02	2.2E-03	1.0E-02	1.1E-03	4.6E-02	1.8E-03	3.2E-03	1.2E-03	6.3E-02
bx4d34	lower right	Exposed	Lead	Germanium	1.6E-02	2.1E-02	1.3E-02	1.4E-02	2.3E-02	8.2E-03	9.2E-03	1.7E-02	2.6E-02	2.6E-02	8.7E-02	2.6E-03	3.1E-02	1.1E-02	2.8E-02	1.7E-02	2.5E-02	1.9E-02	3.1E-02	3.0E-02	5.7E-02
bx4d35	lower right	Shielded	Lead	Germanium	6.7E-02	4.6E-02	3.6E-02	4.4E-02	5.0E-02	2.0E-02	4.0E-02	1.8E-02	3.3E-02	2.3E-02	1.9E-02	4.8E-02	4.4E-02	2.4E-02	3.6E-02	2.5E-02	2.8E-02	3.2E-02	3.5E-02	2.9E-02	1.1E-01
bx4d36	bottom	Exposed	Lead	Germanium	1.5E-02	2.6E-01	1.2E-02	2.2E-02	1.5E-02	1.5E-02	9.0E-03	1.2E-02	1.7E-02	5.0E-02	2.8E-02	1.1E-02	8.9E-03	1.2E-02	1.6E-02	1.3E-02	4.2E-02	1.1E-02	1.5E-02	3.3E-02	2.1E-02
bx4d37	bottom	Shielded	Lead	Germanium	1.6E-02	1.4E-01	4.1E-02	2.8E-02	3.2E-02	2.6E-02	4.5E-02	2.1E-02	7.3E-02	2.0E-02	3.2E-02	1.9E-02	4.5E-02	2.2E-02	5.0E-02	1.5E-02	9.0E-02	1.9E-02	6.2E-02	2.9E-02	3.2E-02
bx4d42	top	Exposed	Lead	Sodium	5.9E-03	1.1E-02	5.7E-03	1.0E-02	2.0E-02	2.0E-02	7.8E-03	7.6E-03	1.2E-02	9.3E-03	1.9E-02	1.0E-02	6.7E-03	8.2E-03	1.0E-02	1.6E-02	3.1E-02	1.4E-02	8.3E-03	2.1E-02	9.6E-02
bx4d43	top	Shielded	Lead	Sodium	7.6E-03	6.8E-03	9.7E-03	8.3E-03	1.0E-02	4.0E-02	1.3E-02	1.6E-02	2.1E-02	1.3E-02	1.9E-02	8.8E-03	1.2E-02	7.7E-03	3.9E-02	6.0E-03	3.3E-02	1.4E-02	4.7E-02	1.0E-02	2.4E-02
bx4d44	upper right	Exposed	Lead	Sodium	4.8E-03	3.8E-02	1.4E-02	1.2E-02	3.0E-03	1.4E-02	5.4E-03	6.6E-03	2.4E-03	6.8E-03	1.4E-01	1.2E-02	2.2E-02	4.6E-03	2.8E-02	2.7E-03	8.6E-02	2.9E-03	4.1E-03	2.6E-03	1.1E-02
bx4d45	upper right	Shielded	Lead	Sodium	1.0E-02	9.9E-03	4.1E-03	7.5E-03	1.5E-03	7.4E-03	2.8E-03	2.6E-03	1.1E-03	1.3E-03	4.8E-02	5.9E-03	1.1E-02	2.6E-03	9.9E-03	1.0E-03	4.1E-02	2.2E-03	2.4E-03	1.7E-03	3.8E-02
bx4d46	lower right	Exposed	Lead	Sodium	7.8E-03	9.4E-03	9.9E-03	1.2E-02	1.6E-02	1.5E-02	7.9E-03	1.4E-02	6.7E-02	1.1E-02	1.3E-01	2.7E-03	2.4E-02	7.8E-03	2.5E-02	3.0E-02	5.7E-02	1.1E-02	1.7E-02	8.5E-03	6.7E-02
bx4d47	lower right	Shielded	Lead	Sodium	1.2E-02	2.2E-02	6.2E-03	1.9E-02	6.6E-03	1.3E-02	1.3E-02	9.0E-03	1.4E-01	1.3E-02	4.3E-02	2.4E-02	2.3E-02	2.2E-02	2.9E-02	8.6E-03	2.5E-02	1.4E-02	1.8E-02	5.3E-03	1.2E-02
bx4d48	bottom	Exposed	Lead	Sodium	7.9E-03	1.0E-02	1.9E-02	1.4E-02	9.2E-03	5.9E-03	7.8E-03	9.9E-03	1.3E-02	6.0E-02	6.0E-02	1.0E-02	9.1E-03	9.4E-03	1.5E-02	6.8E-03	1.0E-01	1.5E-02	1.7E-02	1.2E-02	4.4E-02
bx4d49	bottom	Shielded	Lead	Sodium	7.3E-03	2.1E-02	6.4E-03	1.8E-02	5.9E-03	8.0E-03	1.3E-02	1.9E-02	1.3E-02	2.5E-02	2.1E-01	8.0E-03	2.3E-02	6.4E-03	1.6E-02	1.8E-02	3.0E-02	1.4E-02	2.6E-02	7.5E-03	7.2E-02

Appendix C: Positron's Range

Range and Radiative Stopping Power of Important PET Scanner Design Project Materials

ENERGY = 2921.1 KEV

Ge rho = 5.323 g/cc
 R * rho 2.151772 g/cm²
 SPr / rho 0.124908 MeV cm² / g
 R 0.40424 cm
 SPr 0.664883 MeV / cm

Systematics of Range (same particle in 2 different materials)

$$(R * \rho)_a / (Z / A)_a = (R * \rho)_b / (Z / A)_b$$

Systematics of Radiative Stopping Power (same particle in 2 different materials)

$$(SPr / \rho)_a / (Z^2 / A)_a = (SPr / \rho)_b / (Z^2 / A)_b$$

Ga rho = 5.91 g/cc
 R * rho 2.129902 g/cm²
 SPr / rho 0.122247 MeV cm² / g
 R 0.36039 cm
 SPr 0.722478 MeV / cm

To find SPr for a mixture

$$(SPr / \rho)_{mix} = \sum_j e_j (SPr / \rho)_j$$

where e_j is the weight fraction of the j th element in the mixture

W rho = 19.3 g/cc
 R * rho 2.505633 g/cm²
 SPr / rho 0.190625 MeV cm² / g
 R 0.129826 cm
 SPr 3.679071 MeV / cm

ENERGY = 821.8 KEV

W rho = 19.3 g/cc
 R * rho 0.642603 g/cm²
 SPr / rho 0.045807 MeV cm² / g
 R 0.033295 cm
 SPr 0.884071 MeV / cm

ENERGY = 1820 KEV

W rho = 19.3 g/cc
 R * rho 1.575267 g/cm²
 SPr / rho 0.108155 MeV cm² / g
 R 0.08162 cm
 SPr 2.087393 MeV / cm

Pb rho = 11.35 g/cc
 R * rho 2.543829 g/cm²
 SPr / rho 0.208062 MeV cm² / g
 R 0.224126 cm
 SPr 2.361503 MeV / cm

Pb rho = 11.35 g/cc
 R * rho 0.652399 g/cm²
 SPr / rho 0.049997 MeV cm² / g
 R 0.05748 cm
 SPr 0.567463 MeV / cm

Pb rho = 11.35 g/cc
 R * rho 1.59928 g/cm²
 SPr / rho 0.118048 MeV cm² / g
 R 0.140906 cm
 SPr 1.339845 MeV / cm

Air rho = 1.21E-03 g/cc
 R * rho 1.644238 g/cm²
 SPr / rho 0.040998 MeV cm² / g
 R 1364.513 cm
 SPr 4.94E-05 MeV / cm

ENERGY = 545.4 KEV

W rho = 19.3 g/cc
 R * rho 0.379482 g/cm²
 SPr / rho 0.031336 MeV cm² / g
 R 0.019662 cm
 SPr 0.604789 MeV / cm

Water rho = 1.00E+00 g/cc
 R * rho 1.501763 g/cm²
 SPr / rho 0.041331 MeV cm² / g
 R 1.501763 cm
 SPr 0.041331 MeV / cm

Pb rho = 11.35 g/cc
 R * rho 0.385267 g/cm²
 SPr / rho 0.034203 MeV cm² / g
 R 0.033944 cm
 SPr 0.388199 MeV / cm

Appendix D: Hand Calculations

Nuclear Engineering 472

Senior Design

Hand Calculations for Verification of MCNP/MMT/TORT Calculations

Na-Ne Series

Phantom Distance from Assembly (cm): 127.7

Thickness of Attenuator (cm): 3.81

Source Strength (Bq): 37000000

Unattenuated Calc

$$D^*(r) = \frac{S_p R(E_p)}{4\pi r^2}$$

Gamma Energy (MeV)	Gamma Ray Data		Distance of Respective Source from Phantom (cm)											
	Relative Intensity (fraction of Na decay)	Response Function (rem cm ²)	127.7244691	127.920053	128.3103269	128.8935219	129.6670351	140.4222561	140.6001778	140.9553475	141.4864304	142.1914554		
0.511	0.486419219	9.34E-07	8.20336E-05	8.1783E-05	8.12862E-05	8.05523E-05	7.95941E-05	6.78685E-05	6.76968E-05	6.73561E-05	6.68514E-05	6.61901E-05		
0.170373	0.000151499	2.82E-07	7.6999E-09	7.6764E-09	7.62975E-09	7.56086E-09	7.47093E-09	6.37033E-09	6.35421E-09	6.32223E-09	6.27486E-09	6.21279E-09		
0.011891	0.243047289	2.15E-06	9.43133E-05	9.4025E-05	9.3454E-05	9.26102E-05	9.15086E-05	7.80278E-05	7.78304E-05	7.74387E-05	7.68584E-05	7.60962E-05		
1.27453	0.270381993	2.15E-06	0.000104774	0.00010445	0.000103819	0.000102682	0.000101658	8.66822E-05	8.64629E-05	8.60277E-05	8.53831E-05	8.45385E-05		

Total Dose (mRem hr⁻¹): 5.08025659

Tungsten Attenuated Calc

$$D^*(r) = \frac{S_p R(E_p)}{4\pi r^2} e^{-\mu x}$$

Gamma Energy (MeV)	Gamma Ray Data		Tungsten Data		Distance of Respective Source from Phantom (cm)											
	Relative Intensity (fraction of Na decay)	Response Function (rem cm ²)	Mass Attenuation Factor	Density	Attenuation Factor	127.7244691	127.9200532	128.3103269	128.8935219	129.6670351	140.4222561	140.6001778	140.9553475	141.4864304	142.191455	
0.511	0.486419219	9.34E-07	0.125473	19.25	2.41535525	8.2679E-09	8.24264E-09	8.19257E-09	8.1166E-09	8.02203E-09	6.84025E-09	6.82294E-09	6.7686E-09	6.73774E-09	6.6711E-09	
0.170373	0.000151499	2.82E-07	1.18272	19.25	22.76736	1.63757E-46	1.63257E-46	1.62266E-46	1.609E-46	1.58887E-46	1.35481E-46	1.35138E-46	1.34458E-46	1.3345E-46	1.3213E-46	
0.011891	0.243047289	2.15E-06	21.54	19.25	414.645	0	0	0	0	0	0	0	0	0	0	
1.27453	0.270381993	2.15E-06	0.053651	19.25	1.03278175	2.04809E-06	2.04183E-06	2.02943E-06	2.01111E-06	1.98718E-06	1.69444E-06	1.69015E-06	1.68164E-06	1.66634E-06	1.6525E-06	

Total Dose (mRem hr⁻¹): 0.037160288

Lead Attenuated Calc

$$D^*(r) = \frac{S_p R(E_p)}{4\pi r^2} e^{-\mu x}$$

Gamma Energy (MeV)	Gamma Ray Data		Lead Data		Distance of Respective Source from Phantom (cm)											
	Relative Intensity (fraction of Na decay)	Response Function (rem cm ²)	Mass Attenuation Factor	Density	Attenuation Factor	127.7244691	127.9200532	128.3103269	128.8935219	129.6670351	140.4222561	140.6001778	140.9553475	141.4864304	142.191455	
0.511	0.486419219	9.34E-07	0.146248	11.35	1.6599148	1.47026E-07	1.46577E-07	1.45686E-07	1.44371E-07	1.42654E-07	1.21638E-07	1.21331E-07	1.2072E-07	1.19815E-07	1.1863E-07	
0.170373	0.000151499	2.82E-07	1.51309	11.35	17.1735715	2.95141E-37	2.94239E-37	2.92452E-37	2.89812E-37	2.86364E-37	2.44178E-37	2.4356E-37	2.42334E-37	2.40518E-37	2.3814E-37	
0.011891	0.243047289	2.15E-06	119.11	11.35	1351.8965	0	0	0	0	0	0	0	0	0	0	
1.27453	0.270381993	2.15E-06	0.056245	11.35	0.63838075	9.20342E-06	9.1753E-06	9.11966E-06	9.03723E-06	8.92973E-06	7.61422E-06	7.59496E-06	7.55674E-06	7.50011E-06	7.4259E-06	

Total Dose (mRem hr⁻¹): 0.168971253

Appendix E: Lutetium-Holmium Comparison

Leakage from Hf block with Ge source (1.3175 cm from point source)

Upper Energy (MeV)	Leakage (per nps)	Percent Error
0	7.00E-06	0.378
1.00E-02	7.00E-06	0.378
1.00E-02	6.49E-04	0.0394
1.00E-01	6.49E-04	0.0394
1.00E-01	3.42E-04	0.0541
2.00E-01	3.42E-04	0.0541
2.00E-01	1.32E-02	0.0087
4.00E-01	1.32E-02	0.0087
4.00E-01	6.06E-02	0.0039
1.00E+00	6.06E-02	0.0039
1.00E+00	1.36E-03	0.0271
1.50E+00	1.36E-03	0.0271
1.50E+00	9.50E-05	0.1026
2.00E+00	9.50E-05	0.1026
2.00E+00	1.00E-06	1
2.50E+00	1.00E-06	1

Leakage from Ho block with Ge source (1.3175 cm from point source)

Upper Energy (MeV)	Leakage (per nps)	Percent Error
0	3.00E-06	0.5773
1.00E-02	3.00E-06	0.5773
1.00E-02	5.73E-04	0.0421
1.00E-01	5.73E-04	0.0421
1.00E-01	6.19E-04	0.0402

Leakage from Hf block with Na source (1.3175 cm from point source)

Upper Energy (MeV)	Leakage (per nps)	Percent Error
0	7.00E-06	0.378
1.00E-02	7.00E-06	0.378
1.00E-02	7.00E-04	0.038
1.00E-01	7.00E-04	0.038
1.00E-01	3.97E-04	0.0504
2.00E-01	3.97E-04	0.0504
2.00E-01	1.23E-02	0.009
4.00E-01	1.23E-02	0.009
4.00E-01	5.82E-02	0.004
1.00E+00	5.82E-02	0.004
1.00E+00	4.95E-02	0.0044
1.50E+00	4.95E-02	0.0044

Leakage from Ho block with Na source (1.3175 cm from point source)

Upper Energy (MeV)	Leakage (per nps)	Percent Error
0	5.00E-06	0.4472
1.00E-02	5.00E-06	0.4472
1.00E-02	6.34E-04	0.0404
1.00E-01	6.34E-04	0.0404
1.00E-01	6.68E-04	0.0389
2.00E-01	6.68E-04	0.0389
2.00E-01	1.67E-02	0.0077
4.00E-01	1.67E-02	0.0077
4.00E-01	6.85E-02	0.0037

2.00E-01	6.19E-04	0.0402	1.00E+00	6.85E-02	0.0037
2.00E-01	1.84E-02	0.0073	1.00E+00	5.28E-02	0.0042
4.00E-01	1.84E-02	0.0073	1.50E+00	5.28E-02	0.0042
4.00E-01	7.42E-02	0.0035			
1.00E+00	7.42E-02	0.0035			
1.00E+00	1.46E-03	0.0262			
1.50E+00	1.46E-03	0.0262			
1.50E+00	9.90E-05	0.1005			
2.00E+00	9.90E-05	0.1005			
2.00E+00	1.00E-06	1			
2.50E+00	1.00E-06	1			

Leakage from Hf and Ho block with Na source (1.3175 cm from point source)

Upper Energy (MeV)	Leakage (per nps)	Percent Error
--------------------	-------------------	---------------

0	1.00E-06	1
1.00E-02	1.00E-06	1
1.00E-02	5.59E-04	0.0429
1.00E-01	5.59E-04	0.0429
1.00E-01	6.10E-04	0.0405
2.00E-01	6.10E-04	0.0405

Leakage from Hf and Ho block with Ge source (1.3175 cm from point source)

Upper Energy (MeV)	Leakage (per nps)	Percent Error
--------------------	-------------------	---------------

0	1.00E-06	1
1.00E-02	1.00E-06	1
1.00E-02	5.66E-04	0.0425
1.00E-01	5.66E-04	0.0425
1.00E-01	5.46E-04	0.0429
2.00E-01	5.46E-04	0.0429
2.00E-01	1.74E-02	0.0075
4.00E-01	1.74E-02	0.0075
4.00E-01	7.18E-02	0.0036
1.00E+00	7.18E-02	0.0036
1.00E+00	1.44E-03	0.0263
1.50E+00	1.44E-03	0.0263
1.50E+00	9.90E-05	0.1005
2.00E+00	9.90E-05	0.1005

2.00E-01	1.59E-02	0.0079
4.00E-01	1.59E-02	0.0079
4.00E-01	6.67E-02	0.0037
1.00E+00	6.67E-02	0.0037
1.00E+00	5.23E-02	0.0043
1.50E+00	5.23E-02	0.0043

2.00E+00
2.50E+00

1.00E-06
1.00E-06

1
1

Gamma Leakage vs. Energy with the Germanium Source

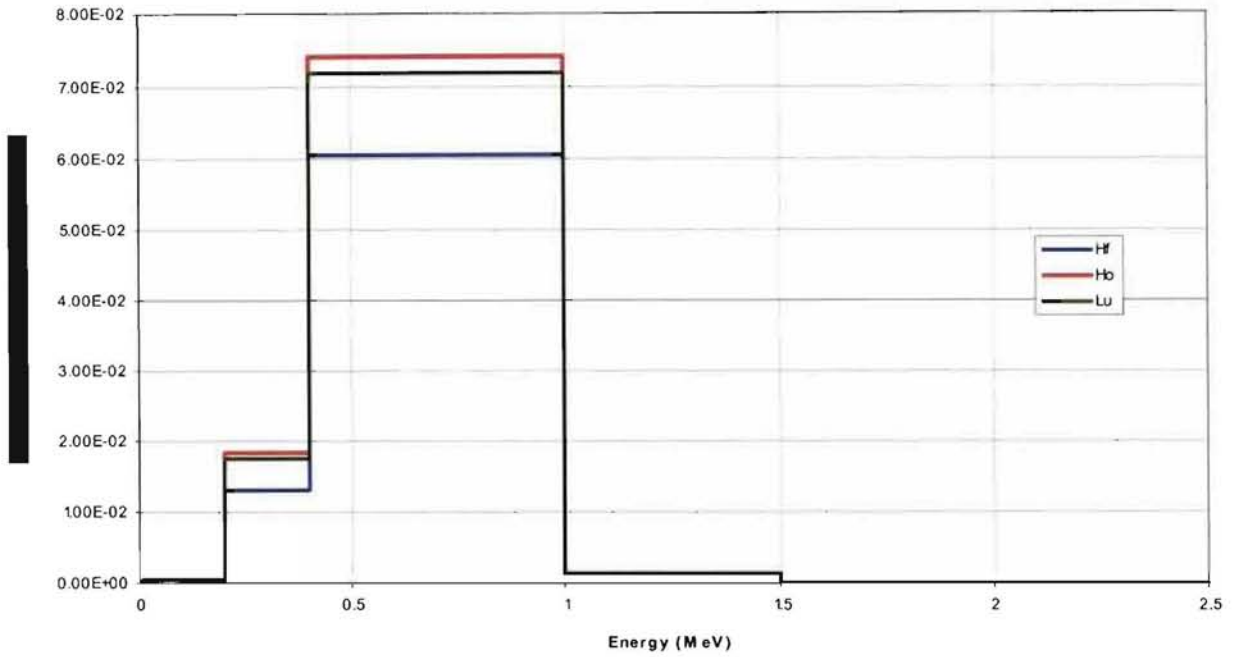

Gamma Leakage vs. Energy with the Sodium Source

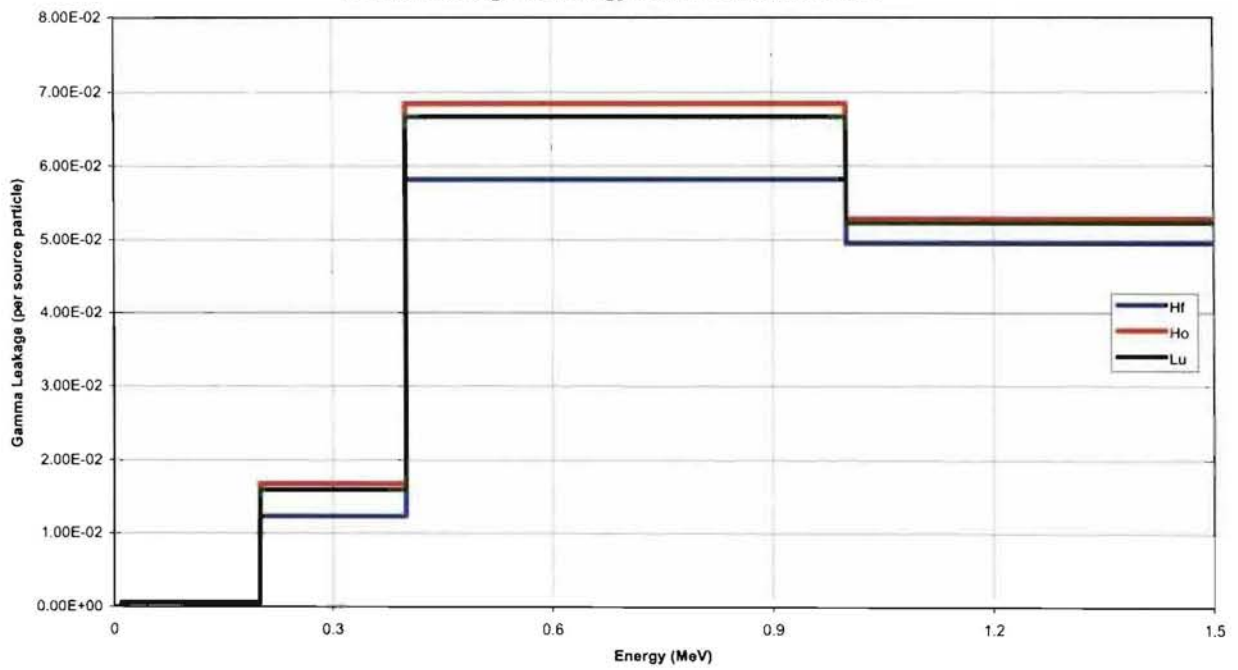

Appendix F: C Program to Strip Output from MCNP

```
/*
Written by: Thomas M. Miller, Allan Wollaber, and Martin Williamson
Title: mcnpread.c
This will prepare read mcnp output for graphing in MATLAB
*/

#include<stdio.h>
#include<string.h>
FILE *fp, *fq;

main(int argc, char *argv[]){

    char item[10], nps[10];
    int tester, i, j, k;
    float mean, std, con;

    /* This is an error message that is printed if the code input and output files
names are
not provided correctly. */

    if(argc != 3){
        system("clear");
        printf("Directions:\n"
            "    (1) To compile type: gcc mcnpread.c\n"
            "    (2) To run type: a.out file_name.in file_name.out\n"
            "\nNote that file_name.in is the name of the file\n"
            "that you want the program to work on.\n"
            "The file_name.out is the name of the file\n"
            "that the program will write output to.\n");
        exit(1);
    }

    fp = fopen(argv[1], "r");
    fq = fopen(argv[2], "w");

    /* The user is now prompted as to where the source is a Ge or Na source. */

    printf("\nPlease enter 1 if source is Ge\n");
    printf("\nPlease enter 2 if source is Na\n");
    scanf("%d",&k);
    if(k==1) {
        con = 1.31946E+08;
    }
    if(k==2) {
        con = 1.3677E+08;
    }

    /* First the code searches for nps. This advances the prompt pass the input file.
*/

    tester = 9;
    while(fscanf(fp, "%s", &item) != EOF){
        tester = strcmp(item, "nps");
        if(tester == 0) {
```

```

        break;
    }
}

/* Next the code advances further into the file looking for the actual value of
nps. */

for(i=0;i<3;i++) {
    tester = 9;
    while((fscanf(fp,"%s", &item) != EOF)&&(tester!=0)){
        tester = strcmp(item, "source");
        if(tester == 0) {
            }
        }
    }
}
tester = 9;
while((fscanf(fp,"%s", &item) != EOF)&&(tester!=0)){
    tester = strcmp(item, "ltally");
    if(tester == 0) {
        }
    }
}
for(i=0;i<2;i++) {
    fscanf(fp,"%s", &item);
}
fscanf(fp, " %s",&nps);

/* After the value of nps is found the prompt is advanced to the point at which
the actual mean and standard deviation of the tallies can be read. */

for(i=0;i<20;i++) {
    while(fscanf(fp,"%s", &item) != EOF){
        tester = strcmp(item, "ltally");
        if(tester == 0) {
            break;
        }
    }
}
}
tester = 9;
while((fscanf(fp,"%s", &item) != EOF)&&(tester!=0)){
    tester = strcmp(item, "ltally");
    if(tester == 0) {
        }
    }
}

/* Now the value of the tallies are read and the units are converted to mrem/hr.
The tallies are then printed to the given output file.
Remember that tally 7 is actually tally 66, which is the absorbed dose to slab
man.
Tally 7 or tally 66 should not be included in the matlab plot. */

fprintf(fq,"This MCNP tally data has been manipulated and is ready for
plotting.\n");
fprintf(fq,"The units of these tallies are mrem/hr.\n");
fprintf(fq,"Tally 7 is the absorbed dose to slab man. DO NOT PLOT TALLY
7!!\n\n");
/* fprintf(fq,"The MCNP output file which was used as input to this code is:
%s\n\n",*argv[1]); */
for(i=0;i<7;i++) {
    tester = 9;

```

```

while((fscanf(fp, " %s", &item) != EOF)&&(tester!=0)){
    tester = strcmp(item, nps);
    if(tester==0) {
        for(k=0;k<3;k++) {
            for(j=0;j<5;j++) {
                if(j==0) {
                    fscanf(fp,"%f", &mean);
                    mean = mean*con*1000;
                    fprintf(fq,"%d %G ",((i*3)+(k+1)), mean);
                }
                if(j==1) {
                    fscanf(fp,"%f", &std);
                    fprintf(fq,"%f \n", std);
                }
                if(j>1) {
                    fscanf(fp,"%f",&mean);
                }
            }
        }
    }
}

fclose(fq);
fclose(fp);

}

```

Appendix G: CTI Drawings

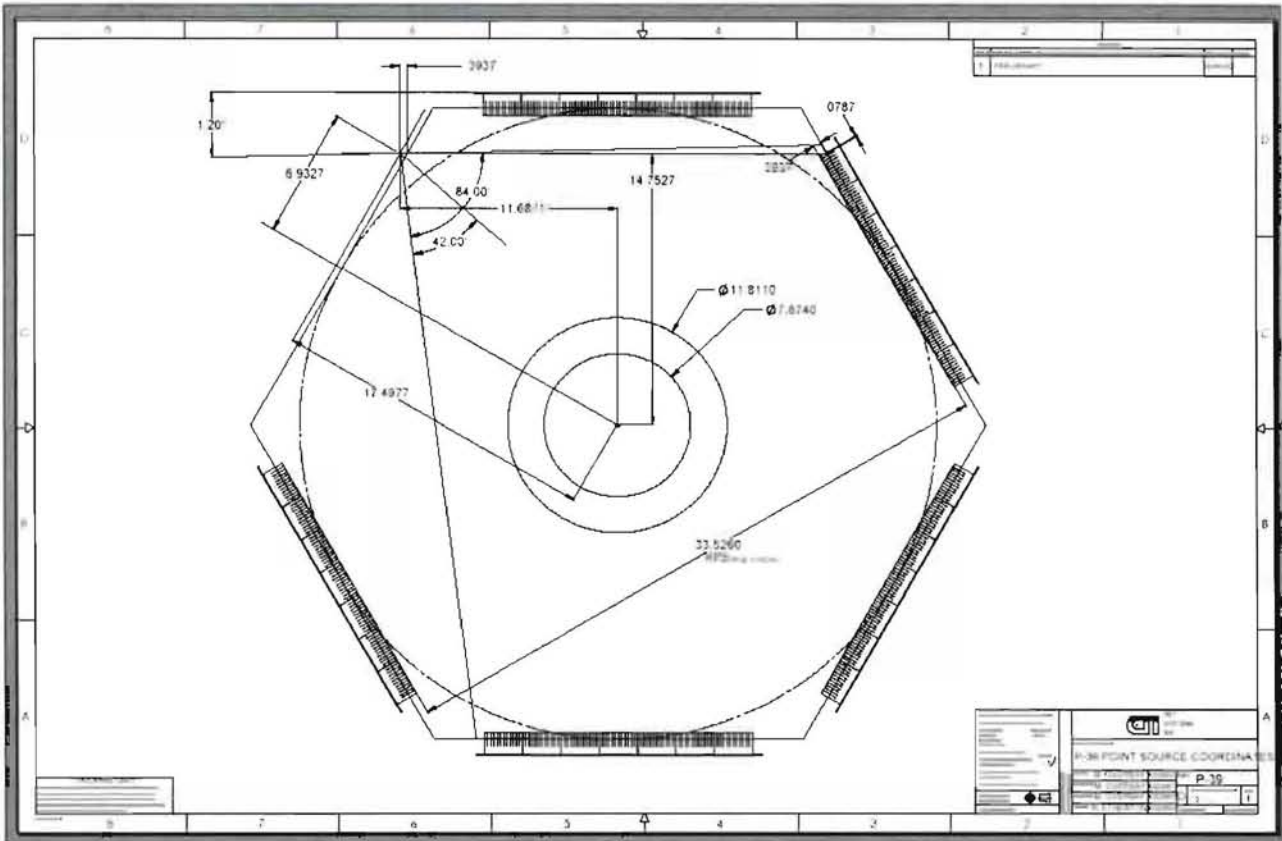

P-39 LSO Sensor Array – Point Source Coordinates

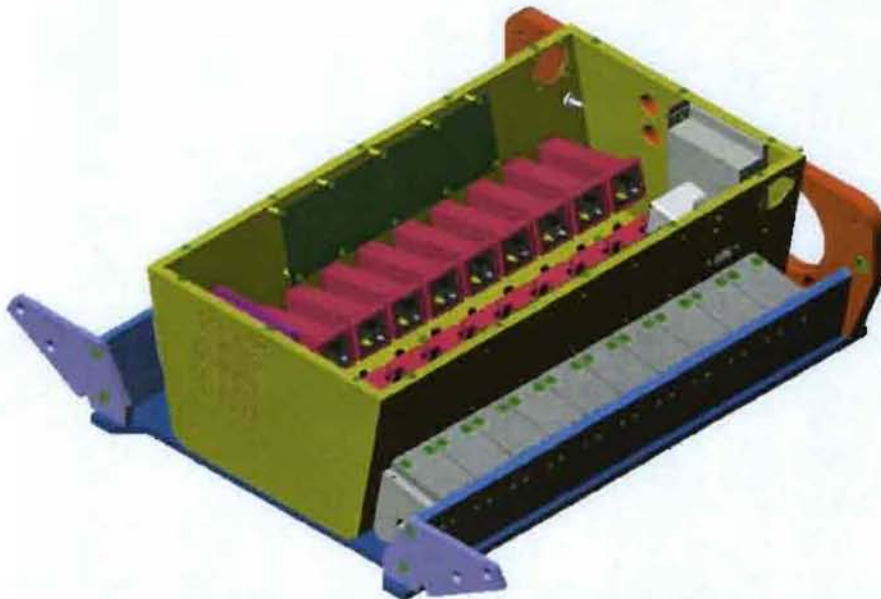

P-39 Point Source 2

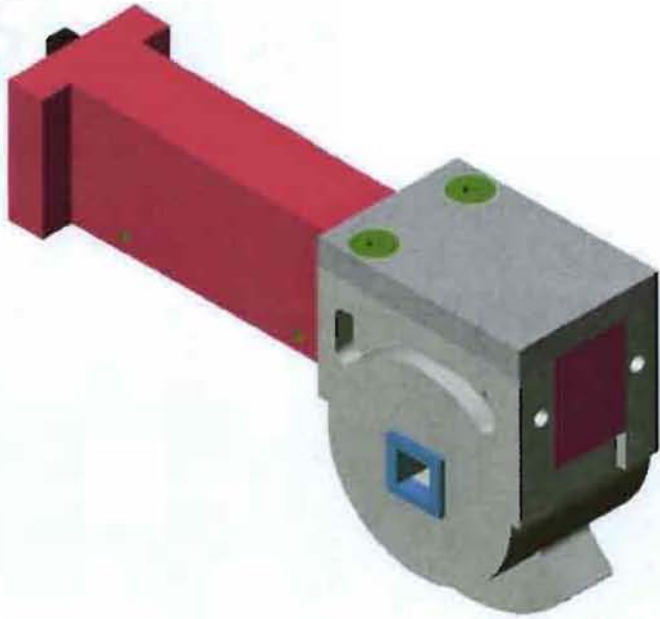

P-39 Point Source – Single Module

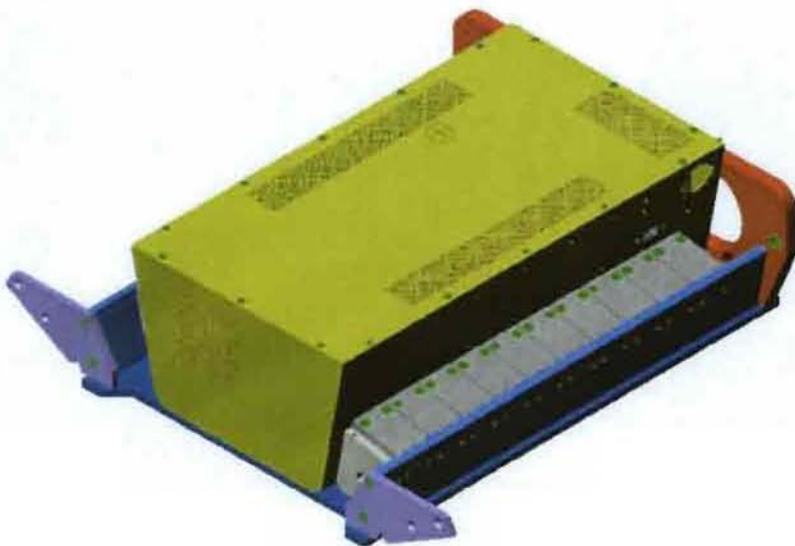

P-39 Point Source

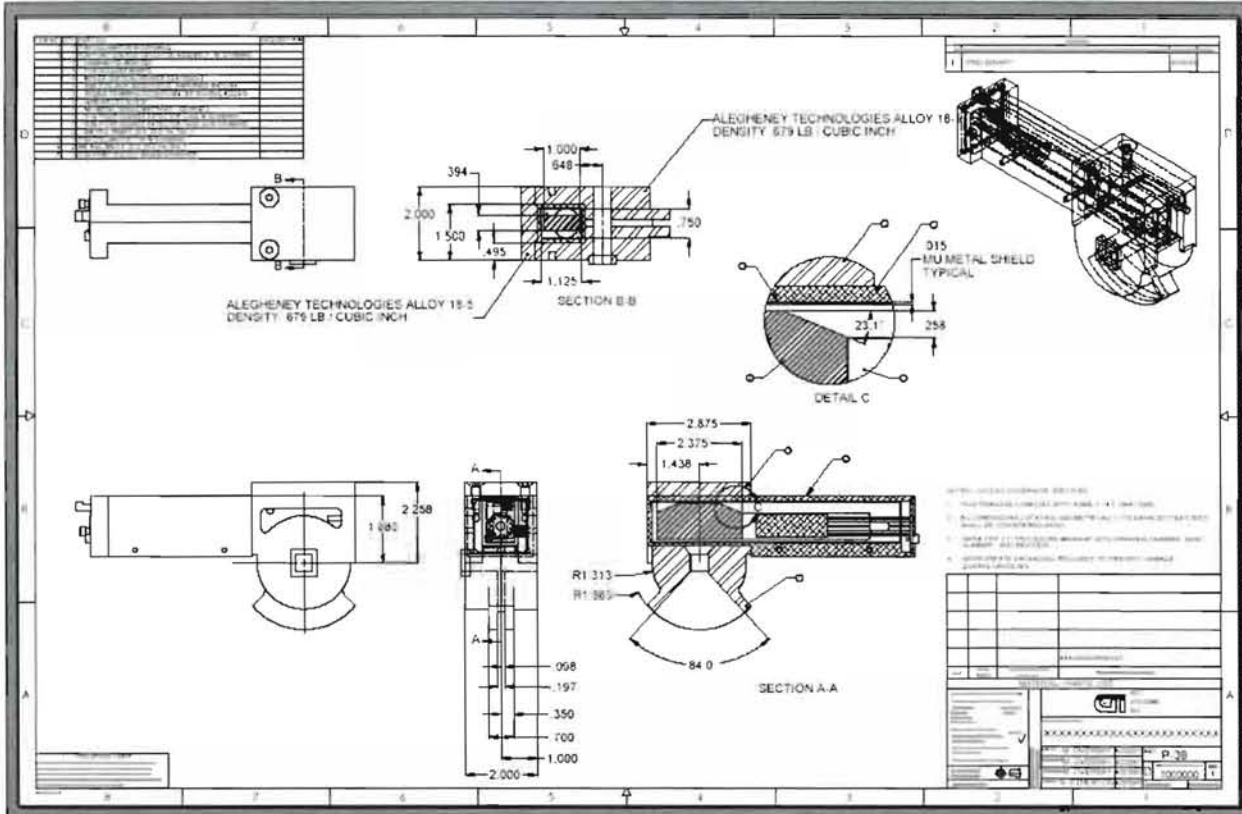

P-39 Point Source Flat Drawings

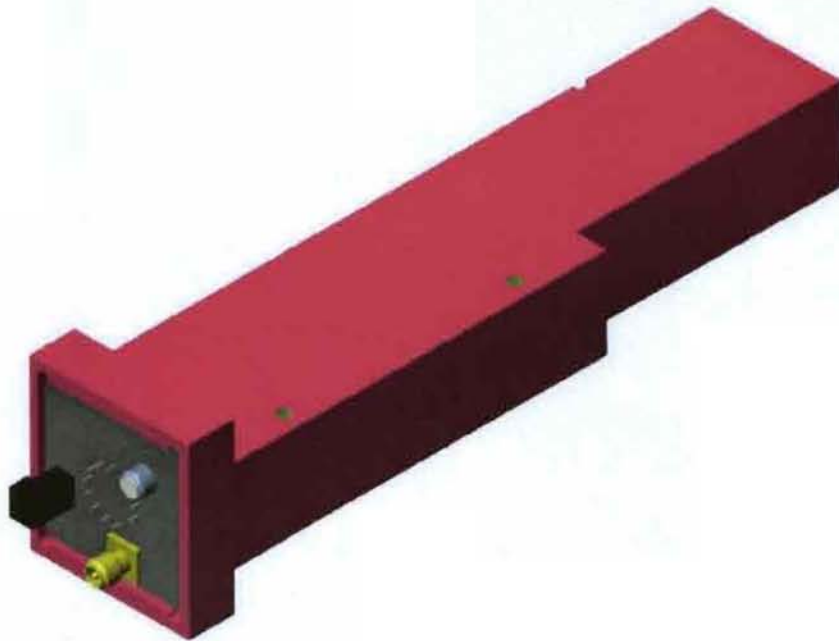

P-39 Point Source Detector

Appendix H: Materials Information

LSO			Number Density	
		Wt%	[atoms/(p ³ cm)]	% ND
Li/Hf	2	76.40%	1.92E-02	25.00%
Si	1	6.13%	9.62E-03	12.50%
O	5	17.47%	4.81E-02	62.50%
TOTAL			7.70E-02	

Tungsten Alloy:			Number Density	
	Abundance	Wt%	[atoms/(p ³ cm)]	% ND
W	1	97.00%	5.97E-02	91.05%
Fe	1	0.90%	1.82E-03	2.78%
Ni	1	2.10%	4.05E-03	6.17%
			6.56E-02	

Steel 1020 number densities
(from previous MCNP input)

Carbon	7.84E-04
Silicon	4.19E-04
Manganese	3.86E-04
Iron	8.36E-02

Tungsten Alloy: (by isotope)			Number Density	
	Abundance	Wt%	[atoms/(p ³ cm)]	% ND
¹⁸² W	0.12%	97%	7.32E-05	0.11%
¹⁸³ W	26.50%	97%	1.60E-02	24.38%
¹⁸⁴ W	14.31%	97%	8.59E-03	13.09%
¹⁸⁵ W	30.64%	97%	1.83E-02	27.88%
¹⁸⁶ W	28.43%	97%	1.68E-02	25.59%
⁵⁴ Fe	5.85%	0.90%	1.10E-04	0.17%
⁵⁶ Fe	91.75%	0.90%	1.67E-03	2.55%
⁵⁷ Fe	2.12%	0.90%	3.79E-05	0.05%
⁵⁸ Fe	0.28%	0.90%	4.96E-06	0.01%
⁵⁸ Ni	68.08%	2.10%	2.79E-03	4.26%
⁶⁰ Ni	26.22%	2.10%	1.04E-03	1.59%
⁶¹ Ni	1.14%	2.10%	4.45E-05	0.07%
⁶² Ni	3.63%	2.10%	1.39E-04	0.21%
⁶⁴ Ni	0.93%	2.10%	3.44E-05	0.05%
			6.56E-02	

Aluminum Alloy: (3003)			Number Density	
		Wt%	[atoms/(p ³ cm)]	% ND
Al	1	98.70%	6.01E-02	99.36%
Cu	1	0.10%	2.59E-05	0.04%
Mn	1	1.20%	3.59E-04	0.59%
			6.05E-02	

High Density Concrete number densities [atoms/(p³cm)]
(from previous MCNP input)

Hydrogen	9.11E-03
Oxygen	4.93E-02
Sodium	1.03E-05
Magnesium	2.09E-04
Aluminum	4.87E-04
Silicon	1.70E-03
Phosphorus	7.64E-06
Sulfur	8.12E-05
Potassium	1.21E-05
Calcium	2.47E-03
Titanium	2.64E-04
Manganese	3.88E-05
Iron	2.48E-02

Water			Number Density	
		Wt%	[atoms/(p ³ cm)]	% ND
H	2	11.19%	6.69E-02	66.67%
O	1	88.81%	3.34E-02	33.33%
TOTAL			1.00E-01	

Lead			Number Density	
isotope	Abundance	[atoms/(p ³ cm)]	% ND	
²⁰⁶ Pb	1.40%	4.69E-04	1.42%	
²⁰⁷ Pb	24.10%	7.99E-03	24.24%	
²⁰⁸ Pb	22.10%	7.29E-03	22.13%	
²⁰⁹ Pb	52.40%	1.72E-02	52.21%	
			3.30E-02	