



8-2007

## Evaluation, Comparison, and Design of Two Experimental Bridges in Tennessee

Kyle Parker Scoble  
*University of Tennessee - Knoxville*

Follow this and additional works at: [https://trace.tennessee.edu/utk\\_gradthes](https://trace.tennessee.edu/utk_gradthes)



Part of the [Civil Engineering Commons](#), and the [Construction Engineering and Management Commons](#)

---

### Recommended Citation

Scoble, Kyle Parker, "Evaluation, Comparison, and Design of Two Experimental Bridges in Tennessee. " Master's Thesis, University of Tennessee, 2007.  
[https://trace.tennessee.edu/utk\\_gradthes/213](https://trace.tennessee.edu/utk_gradthes/213)

This Thesis is brought to you for free and open access by the Graduate School at TRACE: Tennessee Research and Creative Exchange. It has been accepted for inclusion in Masters Theses by an authorized administrator of TRACE: Tennessee Research and Creative Exchange. For more information, please contact [trace@utk.edu](mailto:trace@utk.edu).

To the Graduate Council:

I am submitting herewith a thesis written by Kyle Parker Scoble entitled "Evaluation, Comparison, and Design of Two Experimental Bridges in Tennessee." I have examined the final electronic copy of this thesis for form and content and recommend that it be accepted in partial fulfillment of the requirements for the degree of Master of Science, with a major in Civil Engineering.

J. Harold Deatherage, Major Professor

We have read this thesis and recommend its acceptance:

Edwin G. Burdette, David W. Goodpasture

Accepted for the Council:

Carolyn R. Hodges

Vice Provost and Dean of the Graduate School

(Original signatures are on file with official student records.)

To the Graduate Council:

I am submitting herewith a thesis written by Kyle Parker Scoble entitled "Evaluation, Comparison, and Design of Two Experimental Bridges in Tennessee." I have examined the final electronic copy of this thesis for form and content and recommend that it be accepted in partial fulfillment of the requirements for the degree Master of Science, with a major in Civil Engineering.

J. Harold Deatherage  
Major Professor

We have read this thesis  
and recommend its acceptance:

Edwin G. Burdette

David W. Goodpasture

Accepted for the Council:

Carolyn R. Hodges  
Vice Provost and Dean of the  
Graduate School

Original signatures are on file with official student records

EVALUATION, COMPARISON, AND DESIGN OF TWO EXPERIMENTAL  
BRIDGES IN TENNESSEE

A Thesis  
Presented for the  
Master of Science  
Degree  
The University of Tennessee, Knoxville

Kyle Parker Scoble  
August 2007

Copyright © 2007 by Kyle Scoble  
All rights reserved.

## **DEDICATION**

This thesis is dedicated to my parents, Kevin Scoble and Suzanne Scoble, for their wisdom, guidance and support in helping me reach my goals in life. Words alone can not express my gratitude.

## ABSTRACT

This thesis describes the design and evaluates the adequacy of the moment connection of an experimental two-span highway bridge designed by the Tennessee Department of Transportation. The Massman Drive bridge is an experimental design that unifies the construction economy of simple span bridges and the structural economy of continuous span bridges. The experimental connection, consisting of cover plates and kicker wedge plates, is used to connect the two adjoining girders over the center pier. As a result, the bridge is designed to function as a continuous bridge during the deck pour and behave compositely with the reinforced concrete deck under the live load. After completing a moment comparison analysis, it is concluded that the Massman Drive bridge indeed acts as continuous over the pier as it was designed.

This thesis also compares the measured lateral wheel load distribution factors for two experimental two-span highway bridges designed by the Tennessee Department of Transportation. The measured load distribution factors were then compared to distribution factors from several methods commonly in use such as AASHTO 1996, AASHTO 2001 LRFD, and Henry's Method. Results from American Association of State Highway and Transportation Officials (AASHTO) 1996 produced load distribution factors that were deemed to be conservative. Interior girder load distribution factors from both the DuPont Access and Massman Drive bridges compared well to the AASHTO 2001 Load and Resistance Factor Design (LRFD) specifications. Exterior girder distribution factors compared well with Henry's Method, while the values from AASHTO were consistently high. Also, the factors were consistent between the Massman Drive and DuPont Access bridges.

## TABLE OF CONTENTS

INTRODUCTION .....	1
PART ONE .....	2
ABSTRACT.....	3
1. INTRODUCTION .....	4
1.1 Background.....	4
1.2 Scope.....	4
2. DESIGN PROCESS.....	5
3. RESEARCH METHODOLOGY.....	7
3.1 Bridge Geometry.....	7
3.2 Connection Details.....	7
3.3 Girder Designation and Strain Gage Location.....	8
3.4 Gages, Data Equipment, Software, and Other Equipment.....	9
3.5 Dead Load Test.....	9
3.6 Data.....	9
4. RESULTS .....	10
5. DISCUSSION OF RESULTS .....	11
6. CONCLUSION.....	12
7. ACKNOWLEDGEMENT .....	12
8. NOTATION.....	12
REFERENCES .....	13
APPENDIX.....	15
PART TWO .....	25
ABSTRACT.....	26
1. INTRODUCTION .....	27
1.1 Background.....	27
1.2 Scope.....	27
2. LITERATURE REVIEW .....	28
3. RESEARCH METHODOLOGY.....	30
3.1 Bridge Geometry.....	30
3.2 Girder Designation and Strain Gage Location.....	30
3.3 Gages, Data Equipment, Software, and Other Equipment.....	31
3.4 Controlled Load Test .....	32
4. CURRENT LATERAL LOAD DISTRIBUTION METHODS .....	33
4.1 AASHTO 1996 .....	33
4.2 AASHTO 2001 LRFD .....	33
4.3 AASHTO 2001 LRFD for Exterior Girders (Lever Rule).....	35
4.4 Henry's Method .....	35
5. RESULTS .....	36
6. DISCUSSION OF RESULTS .....	36
7. CONCLUSION.....	37
7. ACKNOWLEDGEMENT .....	38
8. NOTATION.....	38
REFERENCES .....	39



APPENDIX.....	41
VITA.....	58

## LIST OF TABLES

Table 2.1: Controlled Load Test Summary for Massman Drive Bridge.....	42
Table 2.2: Controlled Load Test Summary for DuPont Access Bridge .....	43
Table 2.4: Load Distribution Factors for Massman Drive Bridge .....	44
Table 2.4: Load Distribution Factors for DuPont Access Bridge.....	45

## LIST OF FIGURES

Figure 1.1: Photograph of Massman Drive Bridge Elevation Looking West.....	16
Figure 1.2: Elevation of Massman Drive Bridge.....	16
Figure 1.3: Cross Section of Massman Drive Bridge.....	17
Figure 1.4: Details of Top Cover Plate.....	17
Figure 1.5: Picture of Top Cover Plate.....	18
Figure 1.6: Details of Concrete Diaphragm.....	18
Figure 1.7: Details of Bottom Cover Plates.....	19
Figure 1.8: Picture of Bottom Cover Plate.....	19
Figure 1.9: Details of Wedge Plate.....	20
Figure 1.10: Details of Wedge Plates Inserted Between Girders.....	20
Figure 1.11: Picture of Wedge Plates.....	21
Figure 1.12: Longitudinal Gage Position of Massman Drive Girder with Cross Sections.....	21
Figure 1.13: Cross Section of Massman Drive Girder with Gage Position at Midspan.....	22
Figure 1.14: Deck Pour Sequence.....	22
Figure 1.15: Interior Girder Moment Comparison (Girder 3).....	23
Figure 1.16: Exterior Girder Moment Comparison (Girder 5).....	24
Figure 2.1: Photograph of Massman Drive Bridge Elevation Looking West.....	46
Figure 2.2: Photograph of DuPont Access Bridge Elevation Looking East.....	46
Figure 2.3: Elevation of Massman Drive Bridge.....	47
Figure 2.4: Elevation of DuPont Access Bridge.....	47
Figure 2.5: Cross Section of Massman Drive Bridge.....	48
Figure 2.6: Cross Section of DuPont Access Bridge.....	48
Figure 2.7: Longitudinal Gage Position of Massman Drive Girder with Cross Sections.....	49
Figure 2.8: Cross Section of Massman Drive Girder with Gage Position at Midspan.....	49
Figure 2.9: Longitudinal Gage Position of DuPont Access Girder.....	50
Figure 2.10: Cross Section of DuPont Access Girder with Gage Position.....	50
Figure 2.11: Massman Drive Load Distribution Factors for Load Between Girders 1 and 2 (Positive Moment).....	51
Figure 2.12: Massman Drive Load Distribution Factors for Load Over Girder 2 (Positive Moment).....	51
Figure 2.13: Massman Drive Load Distribution Factors for Load Between Girders 2 and 3 (Positive Moment).....	52
Figure 2.14: Massman Drive Load Distribution Factors for Load Over Girder 3 (Positive Moment).....	52
Figure 2.15: DuPont Access Load Distribution Factors for Load Between Girders E and F (Positive Moment).....	53
Figure 2.16: DuPont Access Load Distribution Factors for Load Over Girder F (Positive Moment).....	53
Figure 2.17: DuPont Access Load Distribution Factors for Load Between Girders F and G (Positive Moment).....	54

Figure 2.18: DuPont Access Load Distribution Factors for Load Over Girder G (Positive Moment).....	54
Figure 2.19: DuPont Access Load Distribution Factors for Load Between Girders G and H (Positive Moment).....	55
Figure 2.20: Comparison of GDF's for Massman Drive Bridge .....	56
Figure 2.21: Comparison of GDF's for DuPont Access Bridge .....	57

## **INTRODUCTION**

The University of Tennessee (UT) entered into research contracts with the Tennessee Department of Transportation (TDOT) in March of 2002. The research involved the instrumentation, testing, and analysis of two experimental bridges. The DuPont Access bridge is located in Humphreys County, Tennessee, and the Massman Drive bridge is located in Nashville, Tennessee.

These two bridges are experimental in that their design unifies the construction economy of simple span bridges and the structural economy of continuous span bridges. The bridge girders were erected as simple spans but were designed to act as continuous beams under the dead load of the concrete deck and as continuous composite girders under the live load.

The purpose of this thesis is to describe and evaluate the design of the moment connection at the pier for the experimental bridges and to present the results of full scale field tests performed to assess the load distribution factors and compare the measured distributions to analytical methods of determining load distribution.

## **PART ONE**

## Design and Evaluation of Experimental Bridges in Tennessee

By Kyle P. Scoble,<sup>1</sup> David P. Chapman,<sup>2</sup> J. Harold Deatherage,<sup>3</sup> P.E., Member, ASCE, Edwin G. Burdette,<sup>4</sup> P.E., Fellow, ASCE, and David W. Goodpasture,<sup>5</sup> P.E., Member, ASCE

This paper was submitted for publication in the ASCE Journal for Performance of Constructed Facilities

### ABSTRACT

This paper describes the design and evaluates the adequacy of the moment connection of an experimental two-span highway bridge designed by the Tennessee Department of Transportation. The Massman Drive bridge is an experimental design that unifies the construction economy of simple span bridges and the structural economy of continuous span bridges. The experimental connection, consisting of cover plates and kicker wedge plates, is used to connect the two adjoining girders over the center pier. As a result, the bridge is designed to function as a continuous bridge during the deck pour and behave compositely with the reinforced concrete deck under the live load. After completing a moment comparison analysis, it is concluded that the Massman Drive bridge indeed acts as continuous over the pier as it was designed.

---

<sup>1</sup> Graduate Research Assistant, Dept. of Civil and Environmental Engineering, Univ. of Tennessee, Knoxville, TN, 37996. (865)-974-4384, Email: kscoble@utk.edu

<sup>2</sup> Graduate Research Assistant, Dept. of Civil and Environmental Engineering, Univ. of Tennessee, Knoxville, TN, 37996. (865)-974-4384, Email: dchapman@utk.edu

<sup>3</sup> Professor, Dept. of Civil and Environmental Engineering, Univ. of Tennessee, Knoxville, TN, 37996. (865)-974-0724, Email: hdeath@utk.edu

<sup>4</sup> Professor, Dept. of Civil and Environmental Engineering, Univ. of Tennessee, Knoxville, TN, 37996. (865)-974-7704, Email: eburdett@utk.edu.

<sup>5</sup> Professor Emeritus, Dept. of Civil and Environmental Engineering, Univ. of Tennessee, Knoxville, TN, 37996. (865)-974-7703, Email: dwg@utk.edu

## **1. INTRODUCTION**

### **1.1 Background**

The University of Tennessee (UT) entered into a research contract with the Tennessee Department of Transportation (TDOT) in March of 2002. The research involved the instrumentation, testing, and analysis of the two-span experimental Massman Drive bridge located in Nashville, Tennessee. The Massman Drive bridge spans over Interstate 40 between Briley Parkway and Spence Lane.

Conventional highway bridges across the state of Tennessee generally fall under two main categories. These include simple span or continuous bridges constructed of steel or reinforced concrete girders. During construction, simple span steel girders need only be placed on the foundation supports; continuous girders require bolting and/or welding of field splices to complete the connections. On two span bridges, there are typically three girder segments that require two field splices. Once constructed, continuous span bridges have advantages over simple span bridges since they are able to distribute moments to every span; simple span bridges must resist the loads in the particular span of load application.

### **1.2 Scope**

The Massman Drive bridge, along with three other bridges in Tennessee, is an experimental design that unifies the construction economy of simple span bridges and the structural economy of continuous span bridges. The bridge girders were erected as simple spans but were designed to act as continuous beams under the dead load of the concrete deck and as continuous composite girders under the live load. The purpose of this paper



is to describe and evaluate the design of the moment connection at the pier for the experimental bridges.

## **2. DESIGN PROCESS**

The Massman Drive bridge was designed by the Structures Division of the Tennessee Department of Transportation (TDOT). Typically, TDOT steel bridge design calls for welded plate girders with a web of constant depth and thickness with flanges of varying thicknesses and widths. Due to the ability to vary the area of the flange, cover plates are rarely used. Instead, splices are placed in the general vicinity of the dead load point of inflection and the beam is usually a continuous cross section over the pier. In the case of the Massman Drive bridge, a committee of section managers and senior engineers agreed on the idea to use a constant girder cross section throughout the bridge. The girders were designed for their self weight in a simple span condition during erection and as continuous under the weight of the fluid concrete during the deck pour. The connection at the pier, which utilizes a cover plate in tension connecting the top flanges, and wedge plates in compression connecting the bottom flanges, makes the structure continuous for all loads except the self weight of the girders and allows the girders to develop negative moment capacity at the pier. The moment at the pier is the maximum moment. The moment connection and plates were designed in accordance with the AASHTO Standard Specifications for Highway Bridges.

Normally, a steel section would not act as simply supported for self weight. They are typically continuous for all loadings and a splice would not be located at the pier. This new design method would require the design of three sections: maximum positive

moment, the section over the pier, and the location where the section over the pier needs a cover plate added for maximum negative moments. The cover plate should start where the non-composite capacity of the girder will no longer carry the negative moment.

For the Massman Drive bridge, the self weight is applied to the simple span girder. If the girder were continuous across the pier, the negative moment would be larger and would require more section over the pier. There is no web over the pier. The cover plate and wedge plates are designed to create a larger moment of inertia to support the large negative moment. The increase of moment of inertia at the pier is approximately 21% larger than that of the normal girder cross section. This method allows for easier fabrication. In the case of the Massman Drive bridge, the slab load is applied to the continuous girder only. Ideally, the plate girder (or rolled section) is designed to support its own weight as a simply supported beam plus the weight of the concrete deck as a continuous beam. However, in the case of the Massman Drive bridge, the girder size had to be increased somewhat to support the live load moment.

The cover plate at the pier accomplishes both the splicing of the girders and supporting the negative moment. The top cover plate is bolted using 72 A325 bolts on both sides of the pier. Welding was not chosen because this would have resulted in a category E fatigue detail. Welding of the bottom plates was not a concern because they are in compression over the pier. The bolts and welds were designed to develop the strength of the cover plate and bottom plates respectively. The cover plate transfers tension to the top plate to provide adequate flexural capacity to the girders. The length may be controlled by the number of bolts required to transfer the load, or it may be controlled by the need to increase the capacity of the non-composite section. Additional

bolts, beyond the number required to develop the necessary strength, may be necessary to meet the stitching/sealing requirements of AASHTO.

### **3. RESEARCH METHODOLOGY**

#### **3.1 Bridge Geometry**

The superstructure of the Massman Drive bridge consists of five steel girders and a concrete deck. The girders, made of 50 ksi weathering steel, are spaced 2.97 m (9 ft 9 in) on center. The north span of the Massman Drive bridge is 42.67 m (140 ft), and the south span is 44.81 m (147 ft). Views of the bridges are shown in Figures 1.1 through 1.3. (All figures appear in the appendices to each part.)

#### **3.2 Connection Details**

The north and south spans of each girder are connected at the pier with a cover plate, two bottom plates, and two wedge plates. All of these connecting parts are made of A790 Grade 50W Steel.

The top flanges are connected using a 5.08 cm x 0.458 m x 3.2 m (2 in. x 1 ft 6 in x 10 ft 6 in) cover plate. A 0.305 m (1 ft) concrete diaphragm separates the two girder ends. Four rows of eighteen 2.54 cm (1 in) diameter A490 Grade 50W bolts, spaced 7.62 cm (3 in) apart in the long direction, are located on each span of the girder. A325 Grade 50 bolts were used in the design process in order to develop the strength in the plate. All bolts are torqued to AASHTO specifications. One and one sixteenth inch holes were drilled in order to meet sealing requirements.

Two 5.08 cm x 0.495 m x 1.448 m (2 in x 1 ft. 7 ½ in x 4 ft. 9 in) bottom cover plates are located on the bottom of each girder on the end closest to the pier. The bottom plates are connected using a 0.794 cm (5/16 in) fillet weld.

Two wedge plates connect the bottom flanges of each girder. The wedge plates measured 5.08 cm thick and 0.597 m long (2 in thick and 1 ft. 11 ½ in long). The top side of the plate measures 13.97 cm (5 ½ in) long and the bottom measures 16.51 cm (6 ½ in). The wedge plates extend 5.08 cm (2 in) longer than the width of the bottom flanges once installed. The wedge plates are connected using a 0.635 cm (¼ in) bevel weld. The details for the connection parts can be seen in Figures 1.4 through 1.11.

### **3.3 Girder Designation and Strain Gage Location**

Eighty - four gages were placed at several different cross-sections along three of the five girders (5, 4, and 3 in Figure 3) in the south span of the Massman Drive bridge. The girders in the Massman Drive bridge are numbered 1-5, with 1 being the easternmost girder. A numbering system was devised such that each gage had a unique three digit number. The first number was the girder number. Girder number 5 was the westernmost girder in the south span, and girder 1 was the easternmost girder in the south span. The next number in the gage title was the cross-section number. There were eight cross sections where gages were placed. Cross section 1 was at the center of the connection between the girders, and cross section 8 was approximately 0.31 m (1 ft) from the face of the abutment. The final number in the gage title was the gage number. Gage number 1 was located on the top of the upper flange, and gage 6 was located on the top of the bottom flange. For example, gage number 586 is located on the top of the bottom flange

of girder 5 about 0.31 m (1 ft) from the face of the abutment. Views of the gage locations for each bridge are shown in Figures 1.12 and 1.13.

### **3.4 Gages, Data Equipment, Software, and Other Equipment**

An Optim Megadac was used to collect data. The wires connecting the gages to the Megadac were contained in a conduit that ran from in front of the abutment to the inside of a mobile data collection laboratory. Data were stored in the Megadac and later downloaded to a computer. The software used to administer a test is called TCS (version 3.4.0); TCS defines the test parameters, runs the test, and formats the data.

### **3.5 Dead Load Test**

The dead load test objective was to determine if there is continuity through the connection over the bridge pier. The dead load test involved a uniform load application, but the researchers had little control over the rate at which the load was applied.

The data acquisition system was programmed to sample at a rate of 0.2 scans/second (i.e. 1 sample per 5 seconds). The strain gages were balanced before the beginning of concrete placement and data were acquired continuously during the two day concrete placement operation. The bridge deck concrete placement was partitioned into five phases. The positive moment area of the south span was poured first. The pouring sequence is shown in Figure 1.14.

### **3.6 Data**

A total of eighty-four weldable strain gages were installed on the three girders. The majority of the strain gages were concentrated around the girder connection. The

gages used for moment comparison were gages 63 through 66 and 73 through 76 for each of the three girders. The 63-66 gages were located .152 m (6 in) away from the end of the cover plate on the south span in the negative moment region, and the 73-66 gages were located near midspan, approximately 21.34 m (70 ft) from the south abutment. Strain values were collected and averaged for the last two minutes of phase 1 of the deck pour and then converted to moments. These values were used because the load applied at this time was known, and there had been insufficient time for the concrete to set and create any composite action. These moments were then compared to the theoretical moment values obtained from computer analysis.

The theoretical behavior of the bridge girders was modeled using Visual Analysis 5.5, developed by Integrated Engineering Software, Inc. (IES, Inc.). Visual Analysis is a finite element structural analysis program that lends itself to low complexity models of materials in the elastic range with small rotations and deflections.

#### **4. RESULTS**

Strain values were averaged for a two minute period following the pouring of the positive moment region of the deck and before pouring for the second phase commenced. This time period was chosen because the load during those time periods was known. Strain values at the top of the bottom flange and at the bottom of the top flange were averaged. This average value was then converted to a moment using the equation  $M = (\epsilon EI)/c$  (Equation 1) where  $\epsilon E$  is substituted for stress ( $\sigma$ ). Due to the use of weldable strain gages, an “effective” modulus of elasticity of 220.6 GPa (32,000 ksi) was applied to the calculation of stress from strain measurements in the steel girders, based on tensile

tests performed in the laboratory. Moments were found on girders 3, 4, and 5 at the 63-66 and 73-76 gages.

The calculated moment values from Visual Analysis were compared to the moments measured in the field to determine if continuity over the pier is achieved. While strain values for all three girders indicated significant negative moment at the pier, consistent with continuous behavior, the measured strains for girder 4 were deemed unreliable and are not included herein. The moment diagrams in Figures 1.15 and 1.16 show a comparison of measured and computed bending moments at the pier and near mid-span for interior girder 3 and exterior girder 5. Calculated moment diagrams for assumptions of both simple and continuous spans are shown in the same figure. The dashed line represents the moment diagram for an assumed simple span; that is, a hinge was assumed to exist at the interior support. The dashed horizontal line for the left span reflects the moment values in a simple span with no load.

## **5. DISCUSSION OF RESULTS**

As shown in Figures 1.15 and 1.16, all of the measured moments are lower than those calculated. While the values plotted in both figures clearly indicate continuous behavior, the results for the exterior girder are questionable; both positive and negative measured moments are much lower than calculated. On the other hand, the measured results for the interior girder 3 shown in Figure 1.15 compare favorably to the theoretical values. Thus, the conclusion was drawn that the bridge was not acting as two simple spans; instead its behavior was clearly consistent with that of a continuous, two span bridge under the dead load of the concrete deck.

## **6. CONCLUSION**

The purpose of this paper was to describe the design and evaluate the adequacy of the moment connection of an experimental two-span highway bridge. The Massman Drive bridge was designed by the Tennessee Department of Transportation to act as continuous over the pier under the dead load of the bridge. The principal conclusion drawn from the research on the Massman Drive bridge was that the method works; continuity over the pier under the dead load of the concrete deck was provided. The design of the new moment connection is reasonable and adequate to create a continuous bridge under the weight of the deck.

## **7. ACKNOWLEDGEMENT**

The work was sponsored by the Tennessee Department of Transportation and the Federal Highway Administration to whom appreciation is extended. The conclusions stated herein are those of the authors and are not necessarily those of the sponsoring agencies.

## **8. NOTATION**

The following symbols are used in this paper:

$M$  = moment of a beam;

$I$  = moment of inertia of a beam;

$c$  = distance from gage to neutral axis;

$\epsilon$  = strain in beam;

$\sigma$  = stress in beam;



## REFERENCES

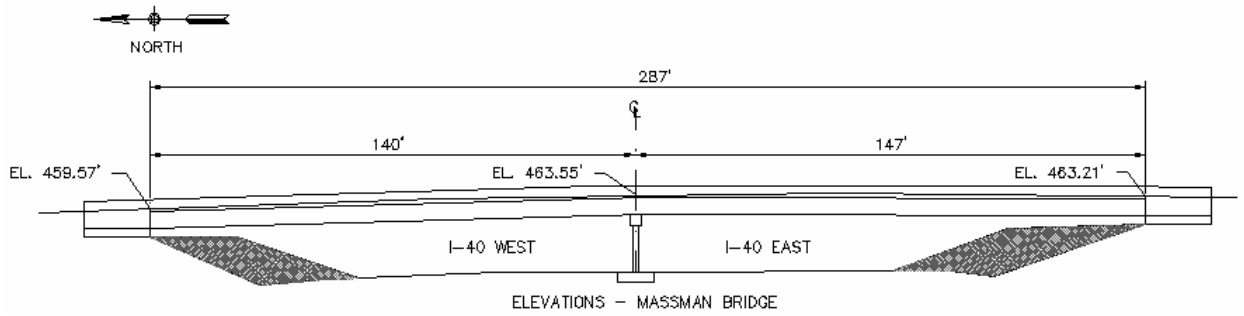
## REFERENCES

- Burdette, E. G., Deatherage, J. H., Goodpasture, D. W. and Ingram, E. E. (2004).  
“Evaluation of Experimental Bridge: DuPont Access Bridge in Humphreys  
County, Final Report.” University of Tennessee at Knoxville, Knoxville,  
Tennessee
- Burdette, E. G., Deatherage, J. H. and Goodpasture, D. W. (2005). “Evaluation of  
Experimental Bridge: Massman Drive Drive Bridge in Davidson County, Final  
Report.” University of Tennessee at Knoxville, Knoxville, Tennessee
- Hastings, J. S., (2007). Quarterly Meeting. Tennessee Department of Transportation.  
Nashville, Tennessee.
- Johnson, T. (2007). Research Meeting. Tennessee Department of Transportation.  
Nashville, Tennessee.

## **APPENDIX**



**Figure 1.1: Photograph of Massman Drive Bridge Elevation Looking West**



**Figure 1.2: Elevation of Massman Drive Bridge**

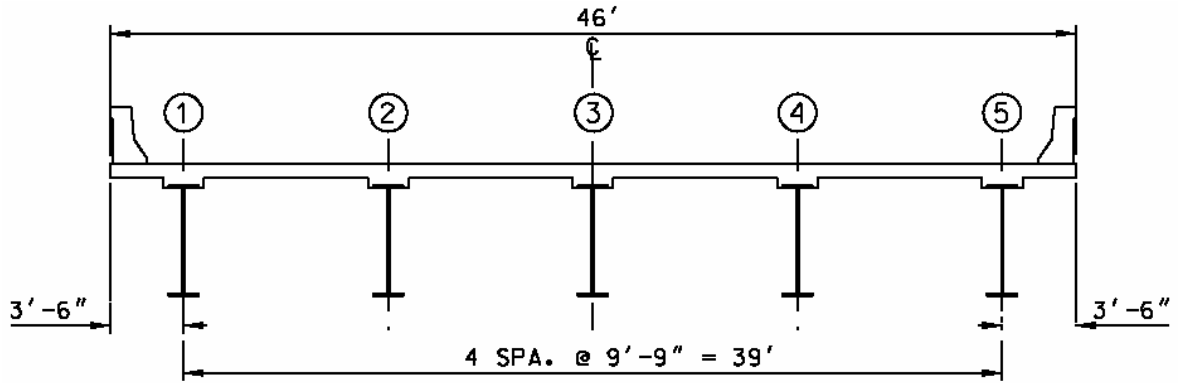


Figure 1.3: Cross Section of Massman Drive Bridge

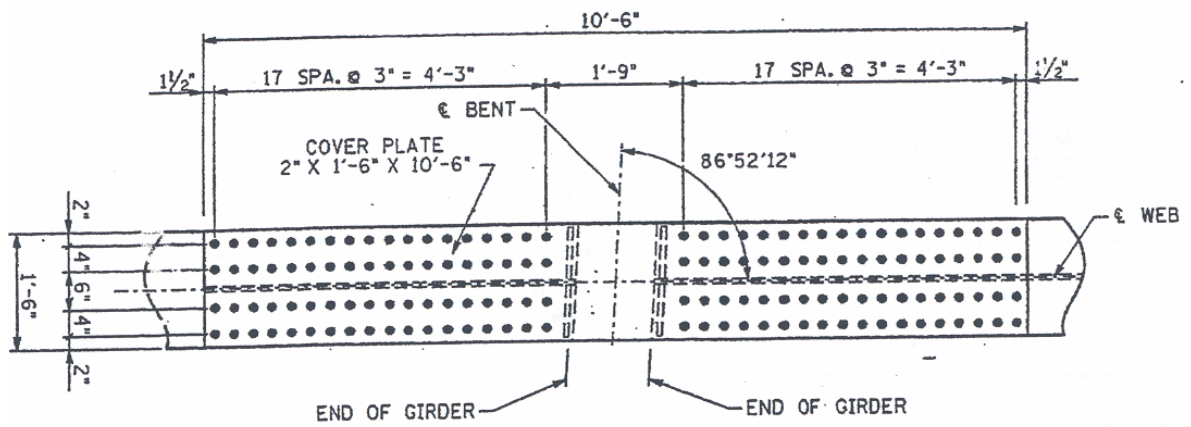
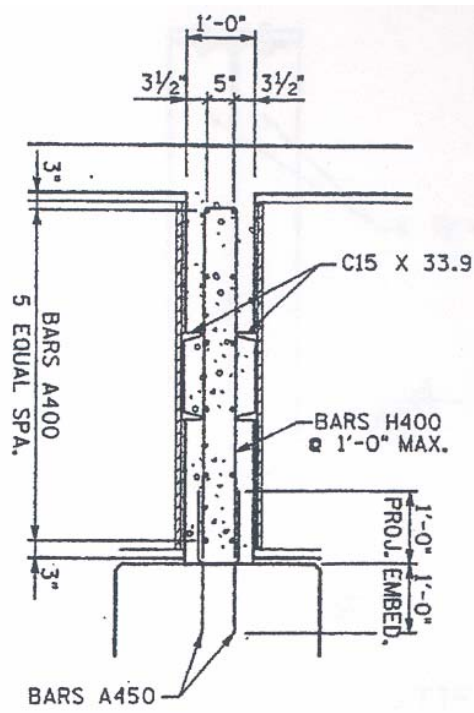


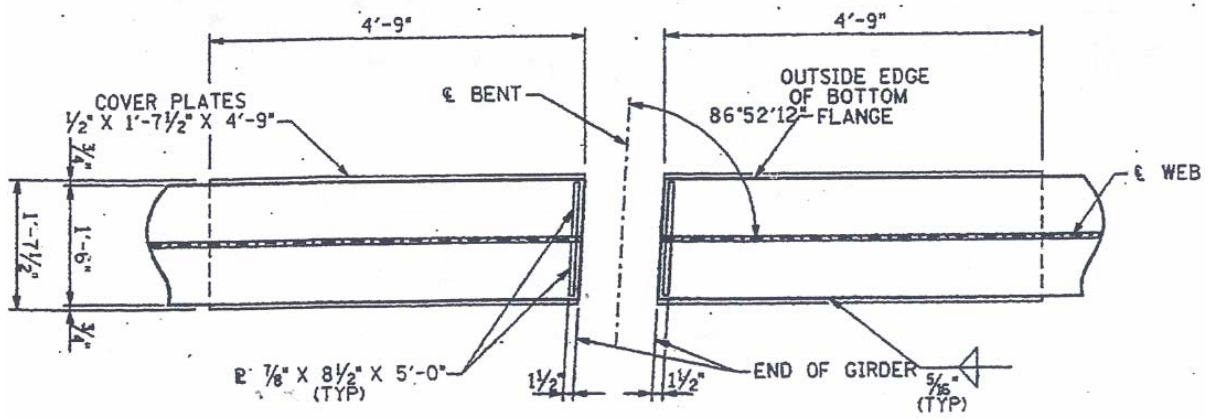
Figure 1.4: Details of Top Cover Plate



**Figure 1.5: Picture of Top Cover Plate**



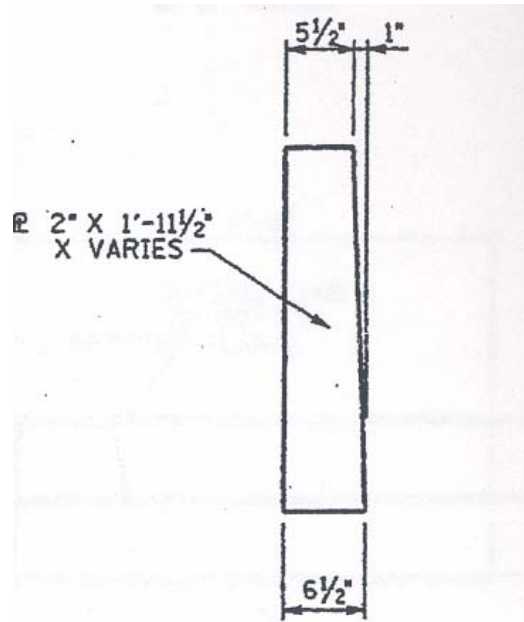
**Figure 1.6: Details of Concrete Diaphragm**



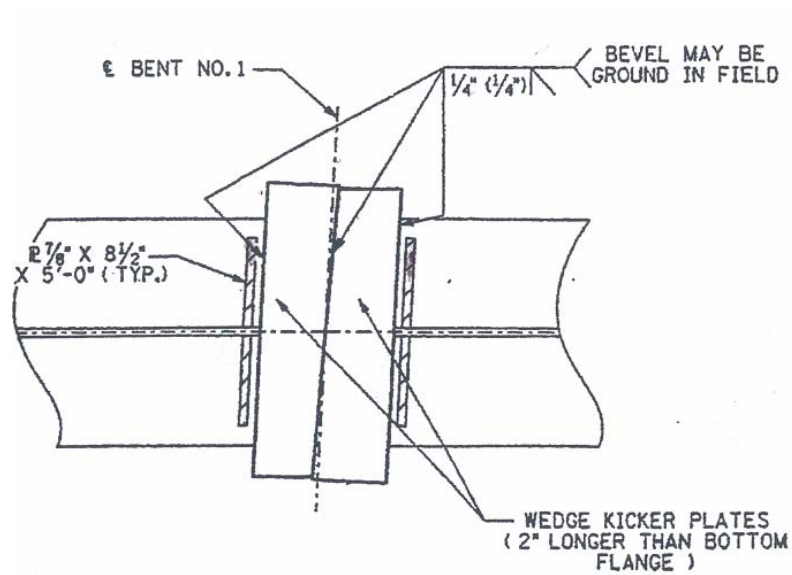
**Figure 1.7: Details of Bottom Cover Plates**



**Figure 1.8: Picture of Bottom Cover Plate**



**Figure 1.9: Details of Wedge Plate**

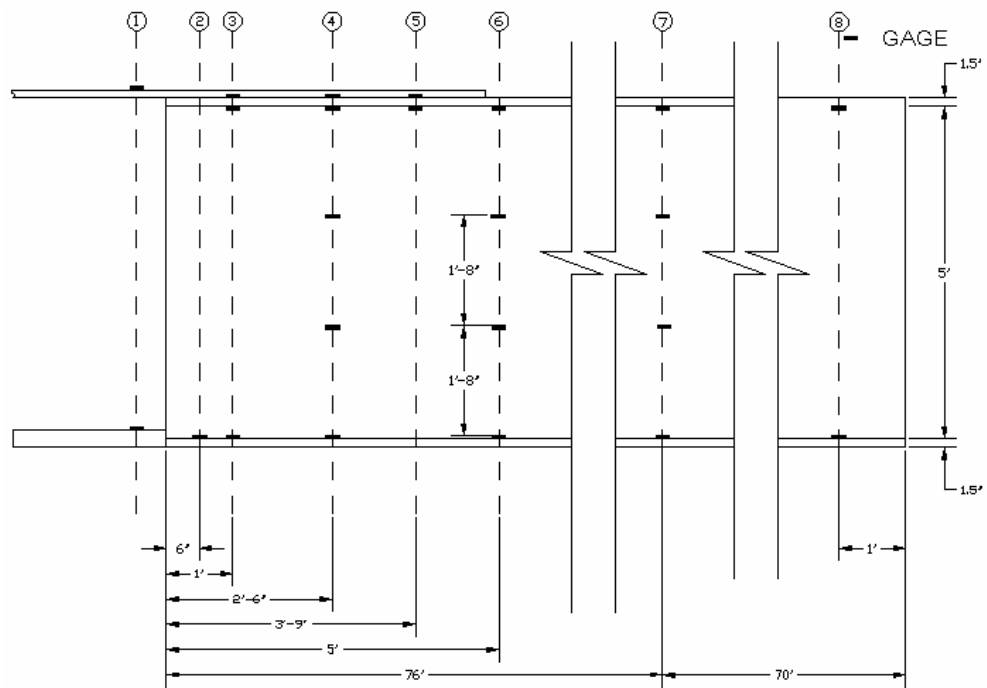


**Figure 1.10: Details of Wedge Plates Inserted Between Girders**

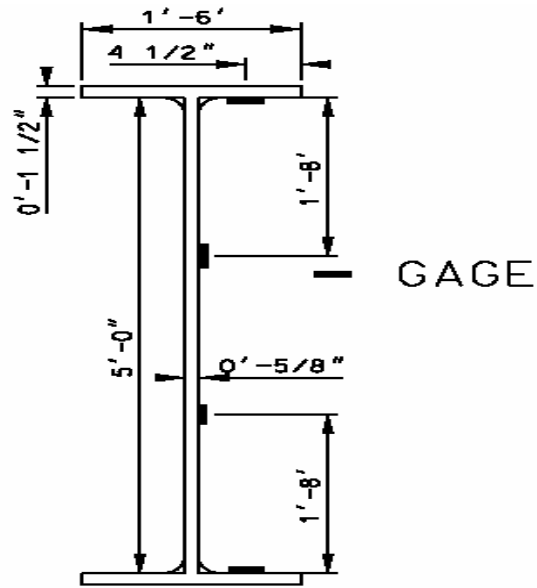




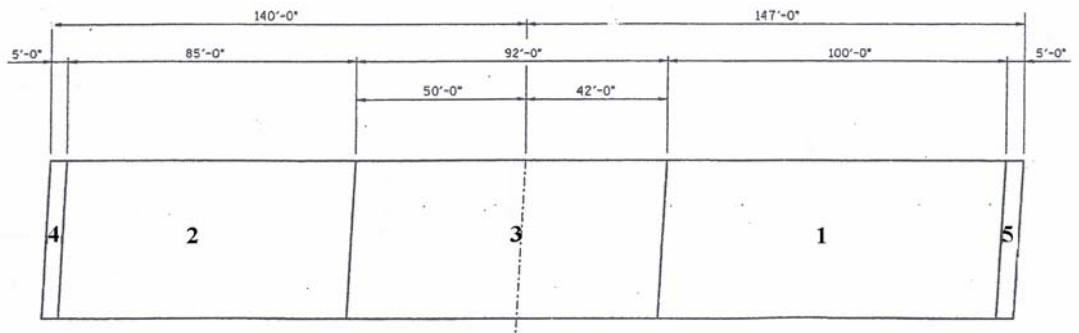
**Figure 1.11: Picture of Wedge Plates**



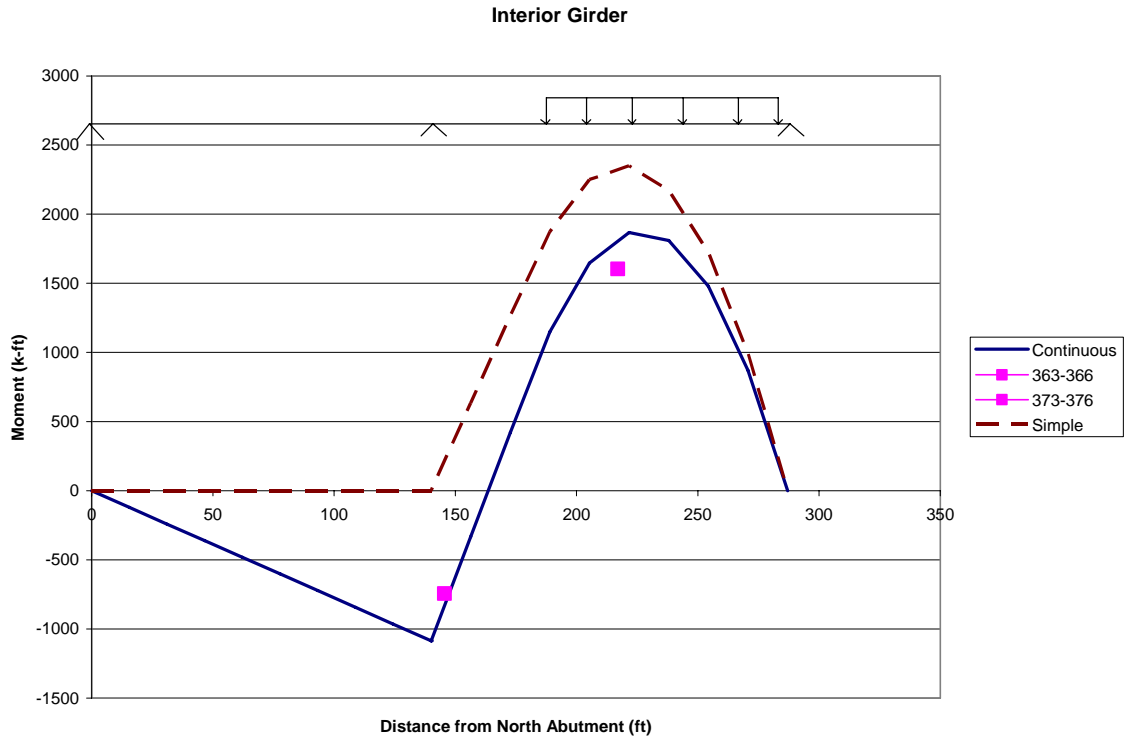
**Figure 1.12: Longitudinal Gage Position of Massman Drive Girder with Cross Sections**



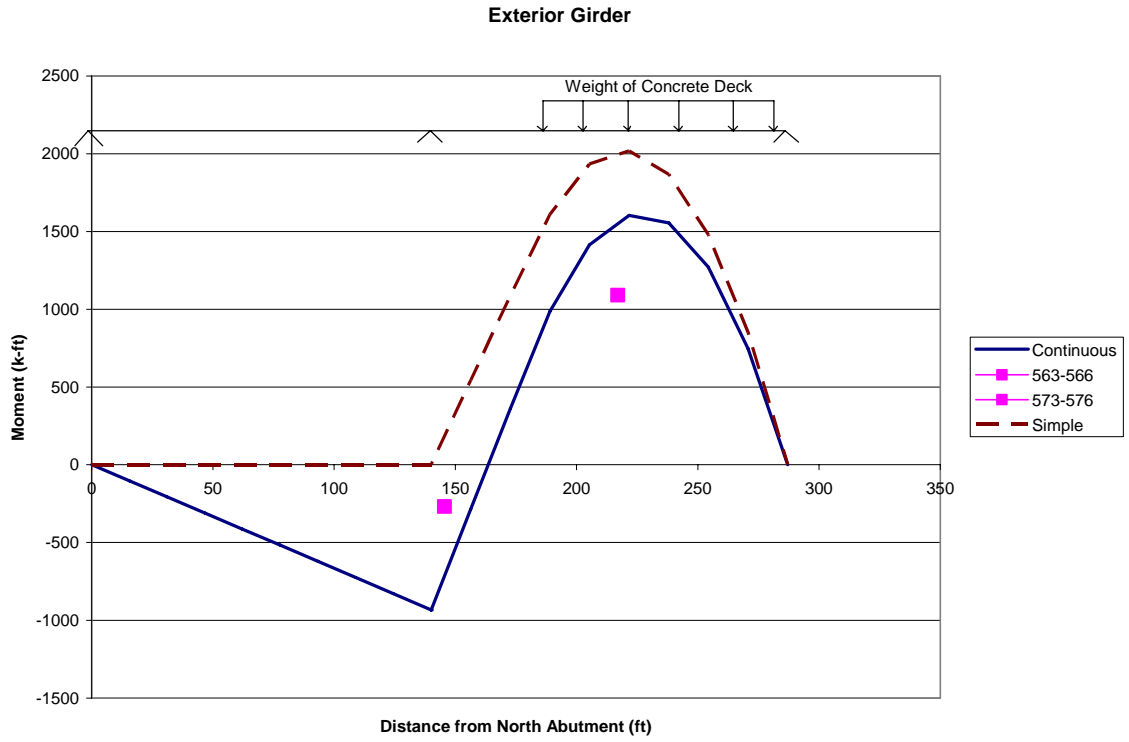
**Figure 1.13: Cross Section of Massman Drive Girder with Gage Position at Midspan**



**Figure 1.14: Deck Pour Sequence**



**Figure 1.15: Interior Girder Moment Comparison (Girder 3)**



**Figure 1.16: Exterior Girder Moment Comparison (Girder 5)**

## **PART TWO**

## Comparison of Lateral Load Distributions of Two Experimental Bridges

By Kyle P. Scoble,<sup>1</sup> David P. Chapman,<sup>2</sup> J. Harold Deatherage,<sup>3</sup> P.E., Member, ASCE, Edwin G. Burdette,<sup>4</sup> P.E., Fellow, ASCE, and David W. Goodpasture,<sup>5</sup> P.E., Member, ASCE

**This paper was submitted for publication in the ASCE Bridge Journal**

### ABSTRACT

This paper compares the measured lateral wheel load distribution factors for two experimental two-span highway bridges designed by the Tennessee Department of Transportation. The measured load distribution factors were then compared to distribution factors from several methods commonly in use such as AASHTO 1996, AASHTO 2001 LRFD, and Henry's Method. Results from American Association of State Highway and Transportation Officials (AASHTO) 1996 produced load distribution factors that were deemed to be conservative. Interior girder load distribution factors from both the DuPont Access and Massman Drive bridges compared well to the AASHTO 2001 Load and Resistance Factor Design (LRFD) specifications. Exterior girder distribution factors compared well with Henry's Method, while the values from AASHTO were consistently high. Also, the factors were consistent between the Massman Drive and DuPont Access bridges.

---

<sup>1</sup> Graduate Research Assistant, Dept. of Civil and Environmental Engineering, Univ. of Tennessee, Knoxville, TN, 37996. (865)-974-4384, Email: kscoble@utk.edu

<sup>2</sup> Graduate Research Assistant, Dept. of Civil and Environmental Engineering, Univ. of Tennessee, Knoxville, TN, 37996. (865)-974-4384, Email: dchapman@utk.edu

<sup>3</sup> Professor, Dept. of Civil and Environmental Engineering, Univ. of Tennessee, Knoxville, TN, 37996. (865)-974-0724, Email: hdeath@utk.edu

<sup>4</sup> Professor, Dept. of Civil and Environmental Engineering, Univ. of Tennessee, Knoxville, TN, 37996. (865)-974-7704, Email: eburdett@utk.edu

<sup>5</sup> Professor Emeritus, Dept. of Civil and Environmental Engineering, Univ. of Tennessee, Knoxville, TN, 37996. (865)-974-7703, Email: dwg@utk.edu

## **1. INTRODUCTION**

### **1.1 Background**

The University of Tennessee (UT) entered into research contracts with the Tennessee Department of Transportation (TDOT) in March of 2002. The research involved the instrumentation, testing, and analysis of two experimental bridges. The DuPont Access bridge is located in Humphreys County, Tennessee, and the Massman Drive bridge is located in Nashville, Tennessee.

The knowledge of girder load distribution factors is important for the design and evaluation of bridges. The overall bridge construction cost is a function of the loads supported by the girders; lower distribution factors indicate a beam is subjected to smaller loads. Smaller loads result in smaller beams which lead to lower costs. Load distribution is affected by the position of the applied load on the superstructure of the bridge. There are several methods for evaluating load distribution, the current method being the 2001 AASHTO-LRFD Specifications. In addition to this code, Henry's Method and the old AASHTO 1996 code were used to compute distribution factors for comparison. Experimental data are needed to assess the accuracy of any method used to predict lateral distribution of wheel loads on highway bridges. The work reported in this paper provides that data for two experimental bridges.

### **1.2 Scope**

The two bridges which were instrumented are experimental in that the girders were erected as simple spans but were designed to act as continuous beams under the dead load of the concrete deck and continuous composite girders under the live load. The

girders are made continuous at the pier by using a cover plate in tension and wedge plates in compression. The purpose of this paper is to present the results of full scale field tests performed to assess the load distribution factors and compare the measured distributions to analytical methods of determining load distribution.

## **2. LITERATURE REVIEW**

Lateral load distribution is a widely studied subject. It is vitally important because it has a direct effect on the strength, economy, and serviceability of highway bridges. Many researchers have studied load distribution factors through full-scale testing and/or finite element analysis. Full-scale testing is a true evaluation of behavior because it includes all the parameters that affect the behavior of a particular bridge. Finite element models must be created carefully in order to model the bridge parameters accurately. Finite element analysis frequently produce unreliable results unless the finite element models are accurately calibrated.

Researchers have been studying load distribution factors and their effects for years. NCHRP (National Cooperative Highway Research Program) Project 12-26 reported an extensive study on “Distribution of Wheel Loads on Highway Bridges.” The study began in the mid 1980’s and suggested that the specifications regarding load distribution should be updated to allow for more accurate calculation of loading effects on highway bridges. The study occurred in two phases with three levels of analysis for each bridge type. Level one of analysis consists of using simple formulas. Level two uses simple computer methods, and level three uses detailed finite element models. The study



provides guidelines and formulas for different methods of calculating load distribution factors.

Several studies have been conducted to determine appropriate load distribution factors. The AASHTO code (1996) determined girder distribution factors based solely on girder spacing and bridge type, while the new AASHTO code takes into account more bridge parameters such as slab thickness, span length, and stiffness. Zokaie (2000) describes the development of the new code and discusses its accuracy. Zokaie found that the newly developed formulas generally produced results that were within five percent of the results produced from finite element analysis.

Fu, Elhelbaway, Sahin, and Schelling (1996) conducted a study using field data to determine the effect of live load distribution for slab-and-beam bridges under the effect of real moving truck loadings by using strain data to get moment fractions. They found the distribution factors for four different bridges to be within the limits set forth by other methods and codes. Kim and Nowak (1997) discuss the procedure and results of field tests that were performed on steel I-girder bridges to determine distribution factors. They too used strain data and concluded that their results were within the limits established by AASHTO values. The methodologies used in previous experimental work are comparable to the techniques used for analyzing the DuPont Access and Massman Drive bridges for the Tennessee Department of Transportation.

### **3. RESEARCH METHODOLOGY**

#### **3.1 Bridge Geometry**

The DuPont Access bridge is a two span bridge supported by integral abutments and a pier located between the east and west bound lanes of U.S. Highway 70. The north span of the bridge is 23.16 m (76 ft) in length while the south span is 26.52 m (87 ft). The bridge consists of six steel I-girders and a concrete deck. The girders are spaced 2.26 m (7 ft - 4 13/16 in) on center. The concrete deck is 209.6 mm (8 ¼ in) thick and acts compositely with the girders under live loads.

The superstructure of the Massman Drive bridge consists of five steel girders and a concrete deck. The girders are spaced 2.97 m (9 ft 9 in) on center. The north span of the Massman Drive bridge is 42.67 m (140 ft) and the south span is 44.81 m (147 ft). Views of the bridges are shown in Figures 2.1 through 2.6.

#### **3.2 Girder Designation and Strain Gage Location**

Each of the six girders in the south span of the DuPont Access Bridge was designated with a letter. The girders are labeled from west to east, starting with the letter “E” for exterior. The second girder is labeled “F,” the third “G,” and so on. Girders E, F, and G have multiple strain gages located at several cross sections along their length. There are 15 gages on each of the three girders for a total of 42. Each gage is identified by a number, and each number corresponds with a specific location on a beam. Gages 0 are the gages that are located just north of the pier on the bottom flange of each girder. Gage E0 is the gage at position zero on girder E. This system of letters and numbers was used to identify all gages in the DuPont Access Bridge.

Eighty - four gages were placed at several different cross-sections along three of the five girders (5, 4, and 3 in Figure 3) in the south span of the Massman Drive bridge. The girders in the Massman Drive bridge are numbered 1-5, with 1 being the easternmost girder. A numbering system was devised such that each gage had a unique three digit number. The first number was the girder number. Girder number 5 was the westernmost girder in the south span, and girder 1 was the easternmost girder in the south span. The next number in the gage title was the cross-section number. There were eight cross sections where gages were placed. Cross section 1 was at the center of the connection between the girders, and cross section 8 was approximately 0.31 m (1 ft) from the face of the abutment. The final number in the gage title was the gage number. Gage number 1 was located on the top of the upper flange, and gage 6 was located on the top of the bottom flange. For example, gage number 586 is located on the top of the bottom flange of girder 5 about 0.31 m (1 ft) from the face of the abutment. Views of the gage locations for each bridge are shown in Figures 2.7 through 2.10.

### **3.3 Gages, Data Equipment, Software, and Other Equipment**

An Optim Megadac was used to collect data. The wires connecting the gages to the Megadac were contained in a conduit that ran from in front of the abutment to the inside of a mobile data collection laboratory. Data were stored in the Megadac and later downloaded to a computer. The software used to administer a test is called TCS (version 3.4.0). TCS defines the test parameters, runs the test, and formats the data.

### **3.4 Controlled Load Test**

Controlled load tests were conducted primarily to determine the lateral load distribution in the girders. The controlled load tests for the DuPont Access Bridge included 14 individual tests, each with the truck in a different lateral position. The truck used in each test was a four axle tandem dump truck provided by TDOT. The truck was loaded with aggregate and weighed 327.08 kN (73.5 kips). In order to concentrate the loads, the movable axle was raised, making the truck illegal for normal road operations. Thus, the load was supported on three axles. The front axle of the truck is 4.82 m (15.83 ft) in front of the second axle. The second and third axles are spaced 1.35 m (4.42 ft) apart. The first individual test, Test 1, was conducted to determine the locations on the bridge where the truck would be located to provide the maximum moments at the midspan gage locations and at the pier strain gage locations. These points were located by moving the truck slowly across the bridge from north to south and monitoring the strain readings at several gages. When a maximum reading occurred, the truck was stopped and the point was marked on the deck with chalk. Point D was where the front axle of the truck was located on the bridge to produce a maximum strain at the midspan, a point located approximately 5.28 m (17.33 ft) from the south abutment. The truck was traveling in the southward direction when this point was marked. The remaining 13 individual tests were conducted to determine the moments on the bridge with the truck in the various lateral positions.

The controlled load testing of the Massman Drive bridge consisted of two phases: tests conducted before the parapet was poured and tests conducted after the parapet was poured. This paper reports the results of the tests conducted after the parapet was poured.

The effects of the parapet on load distribution will be reported at a later date. A tandem dump truck weighing 324.85 kN (73 kips) was used for the controlled loading in a similar fashion as the DuPont Access bridge. The maximum strain at the midspan of the south span occurred when the location of the front axle was located at a point labeled, D, approximately 12.19 m (40 ft) from the south abutment. The truck was driving in the southward direction when this marking was made.

A summary of all the controlled tests along with their speed and position is presented in Tables 2.1 and 2.2.

#### **4. CURRENT LATERAL LOAD DISTRIBUTION METHODS**

The following methods are or have been used to determine lateral load distribution on highway bridges.

##### **4.1 AASHTO 1996**

For one design lane loaded, the distribution of moments on interior girders is the product of axle load moment and the factor  $S/7$  (Equation 1), where  $S$  is the spacing between girders in feet. The value obtained from this formula must be divided by two to apply to an axle load rather than a wheel load. For exterior girders, the lever rule (explained later) applies.

##### **4.2 AASHTO 2001 LRFD**

More accurate results for girder distribution factors can be achieved by using formulae which take into account bridge parameters such as span length and stiffness properties. For concrete decks on steel beams, the lateral load distribution factor for

interior girders with one design lane loaded can be determined using the following equation for interior girders:

$$g_{\text{int}} = 0.06 + \left(\frac{S}{14}\right)^{0.4} \left(\frac{S}{L}\right)^{0.3} \left(\frac{K_g}{12.Lt_s^3}\right)^{0.1} \quad (\text{Equation 2})$$

Where:

$g_{\text{int}}$  = distribution factor for interior beams

$S$  = spacing of beams (ft)

$L$  = span length of deck (ft)

$t_s$  = depth of concrete slab (in)

$K_g$  = longitudinal stiffness parameter (in<sup>4</sup>)

$$K_g = n(I + Ae_g^2) \quad (\text{Equation 3})$$

$$n = \frac{E_B}{E_D} \quad (\text{Equation 4})$$

$E_B$  = modulus of elasticity of beam material (ksi)

$E_D$  = modulus of elasticity of deck material (ksi)

$I$  = moment of inertia of beam (in<sup>4</sup>)

$A$  = area of beam (in<sup>2</sup>)

$e_g$  = distance between the centers of the basic beam and deck (in)

### **4.3 AASHTO 2001 LRFD for Exterior Girders (Lever Rule)**

For one design lane loaded, the girder distribution factor for an exterior girder is computed with the lever rule. The lever rule is a method that sums moments about the first interior girder to get the reaction at the exterior girder, assuming there is a rotational hinge in the bridge deck directly above the first interior girder. Field tests were carried out according to the guidelines set forth by AASHTO. The outer most wheel of the truck was placed directly above the exterior girder and the moment was taken about the first interior girder. The wheels were 1.83 m (6 ft) apart.

### **4.4 Henry's Method**

Henry's Method was developed in 1963 by Director of Structures for the Tennessee Department of Transportation, Henry Derthick. It was created to calculate lateral load distribution of live load moment in longitudinal girders and it assumes equal distribution to all girders. The calculation of live load moment distribution factors for prestressed I-beams and steel beams is as follows.

(a) A 3.05 m (10 ft) traffic lane width is assumed, and the fractional number of design traffic lanes is obtained by dividing the roadway width by 10.

(b) The Live Load Resistance Factor (LLRF) expressed as a percentage is obtained by linearly interpolating the number of traffic lanes obtained in step (a) from the scale below:

2 lanes = 100%

3 lanes = 90%

4 lanes = 75%

(c) Multiply the LLRF by the number of traffic lanes obtained in (a) and divide the product by the number of beams.

(d) Multiply (c) by 2 for number of rows of wheels per beam.

(e) Multiply (d) by the ratio 6/5.5 to get the Live Load Moment Distribution Factor for girders.

## **5. RESULTS**

The lateral load distributions of moment in the girders at different locations for the Massman Drive bridge are shown in Figures 2.11 through 2.14, and those for DuPont Access Bridge are located in Figures 2.15 through 2.19.

The calculated and measured load distribution factors are tabulated in Tables 2.3 and 2.4. Figures that show the comparison of girder distribution factors can be seen in Figures 2.20 and 2.21.

## **6. DISCUSSION OF RESULTS**

Girder distribution factors calculated using AASHTO 1996, the Lever Rule, and Henry's Method are higher in the Massman Drive bridge than in the DuPont Access Bridge due to fewer girders and larger spacing in the Massman Drive bridge. The AASHTO LRFD values for interior girders, while slightly higher for Massman, compare similarly between the two bridges with values of 0.457 for Massman and 0.418 for DuPont. The load distribution factors from field measurements for DuPont Access and Massman Drive were consistently below the values set forth by AASHTO 1996 for both the interior and exterior cases. The field measurements for interior girders are closer to the standard AASHTO LRFD value than are those for the exterior girder cases. The



cantilever method for distributing loads to exterior girders is used in AASHTO 1996 and AASHTO LRFD. Based on the test results reported herein, this method is ultra-conservative. This conservatism results from the assumption in the cantilever method that the slab is pinned at the first interior girder. As illustrated in Figures 20 and 21, the result is a distribution factor to exterior girders that is unrealistically large. Both bridges experience a girder distribution factor between 0.4 and 0.5 for the load case nearest the exterior girder. Load factors decrease in value as the truck is moved closer to the centerline of each bridge. This was expected because as the truck moves toward the center of the bridge, the load is dispersed through more girders.

## **7. CONCLUSION**

The purpose of this paper was to compare the load distribution factors for two experimental two-span highway steel girder bridges. The girder distribution factors from field measurements were consistently less than those obtained by any of the design methods. The AASHTO LRFD values were closer than those obtained by any other method when comparing interior girders. On the other hand, exterior girder distribution factors were closer to the values produced from Henry's Method. The AASHTO LRFD values for exterior girders obtained by the lever rule are consistently higher than those obtained from Henry's Method and significantly higher than those measured. The long-used cantilever method is extremely conservative. AASHTO 1996 distribution factors were shown to be conservative across the board when compared with field measurements. The girder distribution factors obtained for the two bridges were reasonably consistent.

## 7. ACKNOWLEDGEMENT

The work was sponsored by the Tennessee Department of Transportation and the Federal Highway Administration to whom appreciation is extended. The conclusions stated herein are those of the authors and are not necessarily those of the sponsoring agencies.

## 8. NOTATION

The following symbols are used in this paper:

$A$  = area of beam;

$E_B$  = modulus of elasticity of beam material;

$E_D$  = modulus of elasticity of deck material;

$e_g$  = distance between the centers of the basic beam and deck;

$g_{int}$  = distribution factor for interior beams;

$I$  = moment of inertia of beam;

$K_g$  = longitudinal stiffness parameter;

$L$  = span length of deck;

$n$  = ratio of beam modulus of elasticity to deck modulus of elasticity;

$S$  = spacing of beams; and

$t_s$  = depth of concrete slab.

## REFERENCES

## REFERENCES

- Burdette, E. G., Deatherage, J. H., Goodpasture, D. W. and Ingram, E. E. (2004).  
“Evaluation of Experimental Bridge: DuPont Access Bridge in Humphreys  
County, Final Report.” University of Tennessee at Knoxville, Knoxville,  
Tennessee
- Burdette, E. G., Deatherage, J. H. and Goodpasture, D. W. (2005). “Evaluation of  
Experimental Bridge: Massman Drive Drive Bridge in Davidson County, Final  
Report.” University of Tennessee at Knoxville, Knoxville, Tennessee
- Fu, Chung, Elhelbawey, M, Sahin, M. A., Schelling, D. R. (1996). “Lateral Distribution  
Factor from Bridge Field Testing”, *Journal of Structural Engineering, ASCE*,  
*September 1996*.
- Kim, Sangjin, Nowak, A. S. (1997). “Load Distribution and Impact Factors for I-Girder  
Bridges”, *Journal of Bridge Engineering, ASCE, August 1997*.
- Wang, N., (2005). “Modeling and Analysis of the DuPont Access Bridge.” University of  
Tennessee at Knoxville, Knoxville, Tennessee
- Zokaie, Toorak, (2000). “AASHTO – LRFD Live Load Distribution Specification”,  
*Journal of Bridge Engineering, ASCE, May 2000*.
- Zokaie, Toorak, (1992). “Distribution of Wheel Loads on Highway Bridges”, *NCHRP  
Research Results Digest, Project 12-26, May 1992*.

## **APPENDIX**

**Table 2.1: Controlled Load Test Summary for Massman Drive Bridge**

Test	Location of Truck					Speed of Travel
	5	4	3	2	1	
1	x					Static
2	x	x				Static
3		x				Static
4		x	x			Static
5			x			Static
6			x	x		Static
7				x		Static
8				x	x	Static
9					x	Static
10	x	x				Rolling
11			x			Rolling
12				x	x	Rolling
13				x	x	Traffic
14	x	x				Traffic
15		x				Rolling
16				x		Rolling
17			x			Rolling

**Table 2.2: Controlled Load Test Summary for DuPont Access Bridge**

Test	Location of Truck						Speed of Travel	
	E	F	G	Centerline	H	I		J
1		x	x					Static
2	x	x						Static
3		x						Static
4			x					Static
5				x				Static
6					x			Static
7					x			Static
8						x		Static
9						x		Static
10		x	x				x	Static
11	x	x						Static
12		x	x					Rolling
13		x	x					Rolling
14		x	x					Rolling

**Table 2.3: Load Distribution Factors for Massman Drive Bridge**

AASHTO 1996 (Interior)	AASHTO LRFD (Interior)	AASHTO LRFD (Exterior)	Henry's Method (Int/Ext)	Research Analysis		
				Lateral Truck Location	GDF	Located on Girder Type
0.696	0.457	0.692	0.690	1 & 2	0.5	Exterior
				2	0.37	Exterior
				2 & 3	0.28	Interior
				3	0.41	Interior



**Table 2.4: Load Distribution Factors for DuPont Access Bridge**

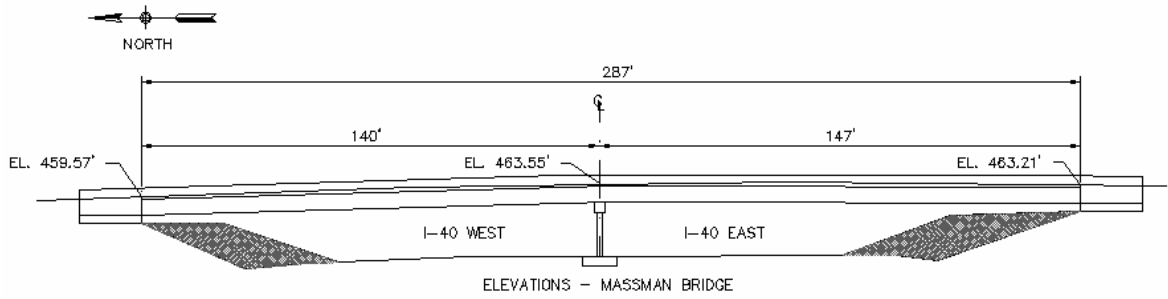
AASHTO 1996 (Interior)	AASHTO LRFD (Interior)	AASHTO LRFD (Exterior)	Henry's Method (Int/Ext)	Research Analysis		
				Lateral Truck Location	GDF	Located on Girder Type
0.529	0.418	0.595	0.539	E & F	0.415	Exterior
				F	0.378	Interior
				F & G	0.338	Interior
				G	0.329	Interior
				G & H	0.294	Interior



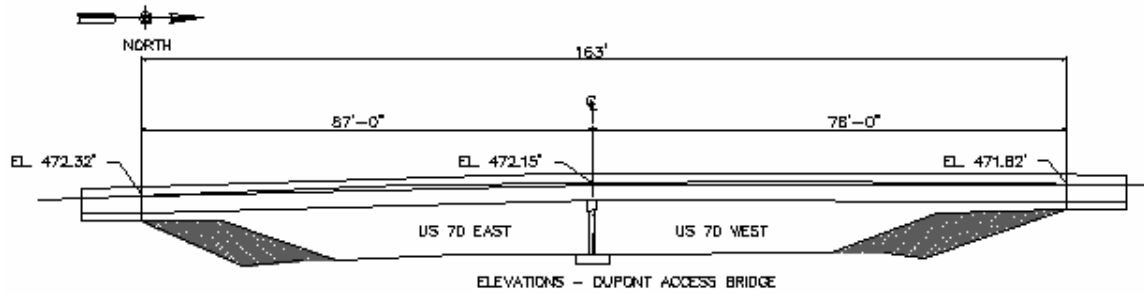
**Figure 2.1: Photograph of Massman Drive Bridge Elevation Looking West**



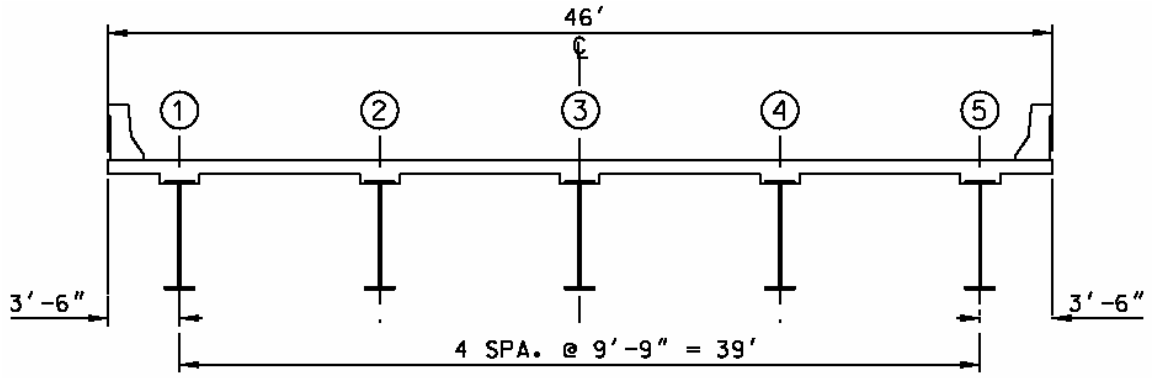
**Figure 2.2: Photograph of DuPont Access Bridge Elevation Looking East**



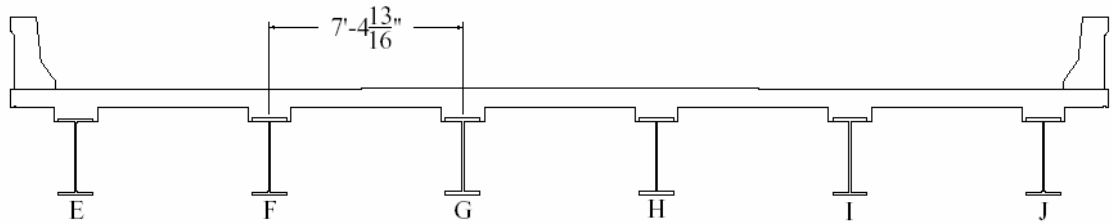
**Figure 2.3: Elevation of Massman Drive Bridge**



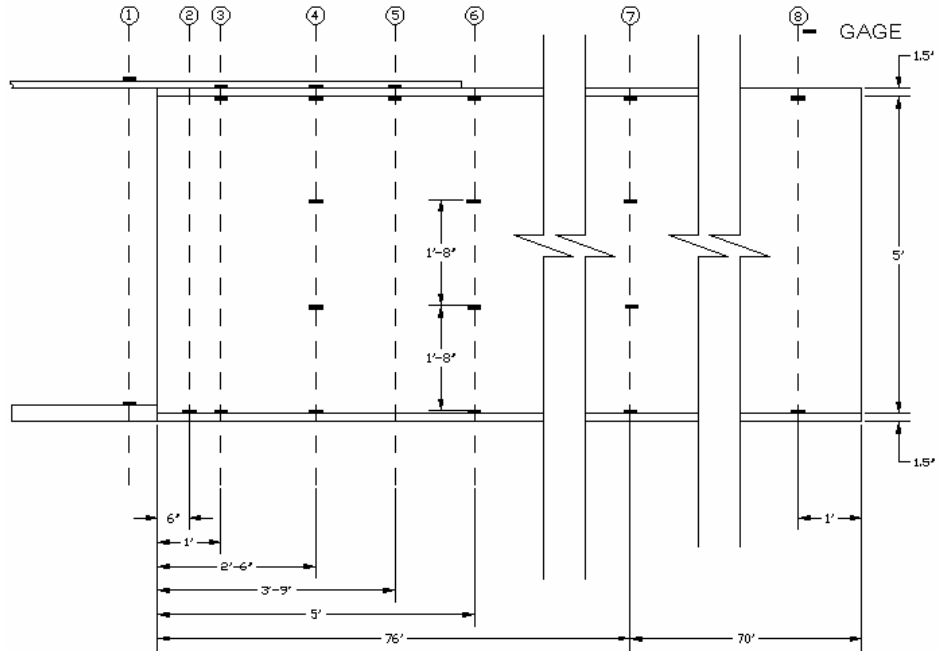
**Figure 2.4: Elevation of DuPont Access Bridge**



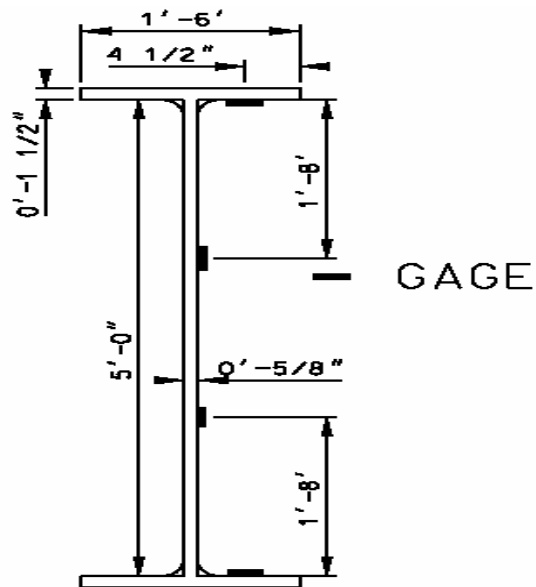
**Figure 2.5: Cross Section of Massman Drive Bridge**



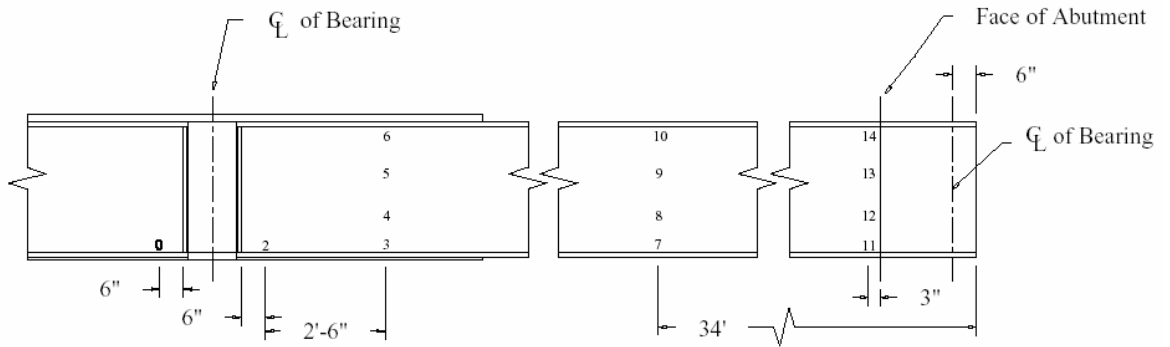
**Figure 2.6: Cross Section of DuPont Access Bridge**



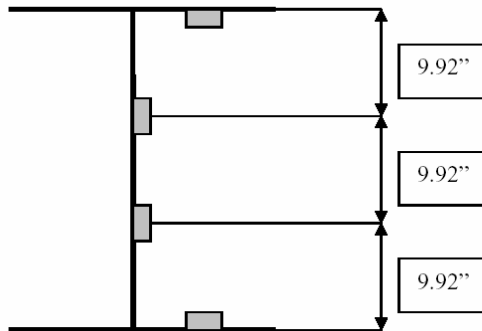
**Figure 2.7: Longitudinal Gage Position of Massman Drive Girder with Cross Sections**



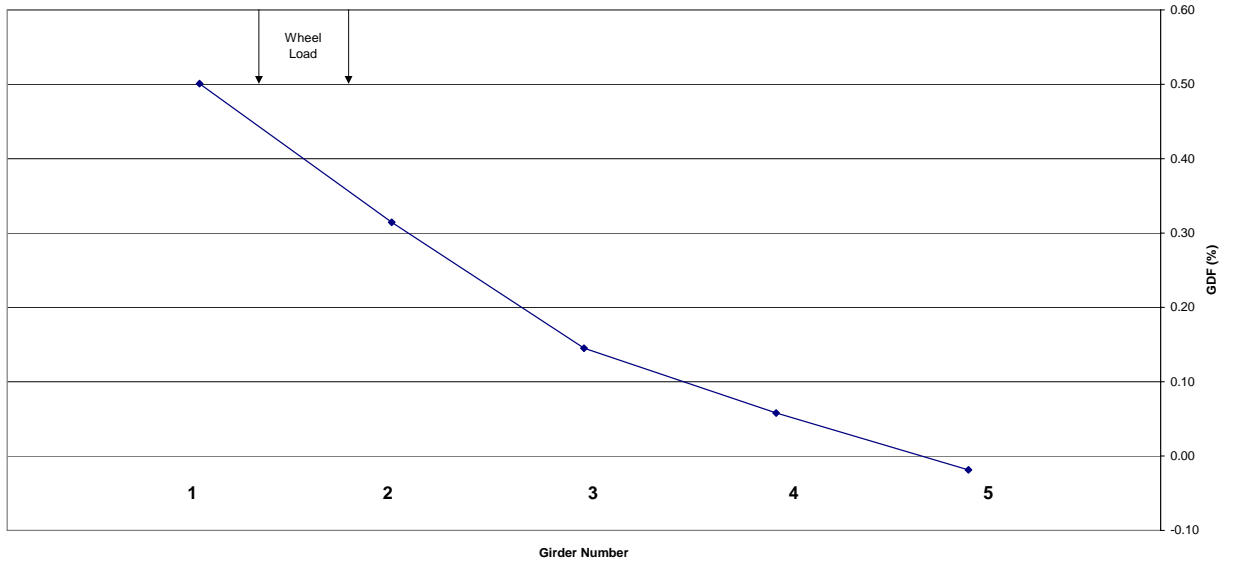
**Figure 2.8: Cross Section of Massman Drive Girder with Gage Position at Midspan**



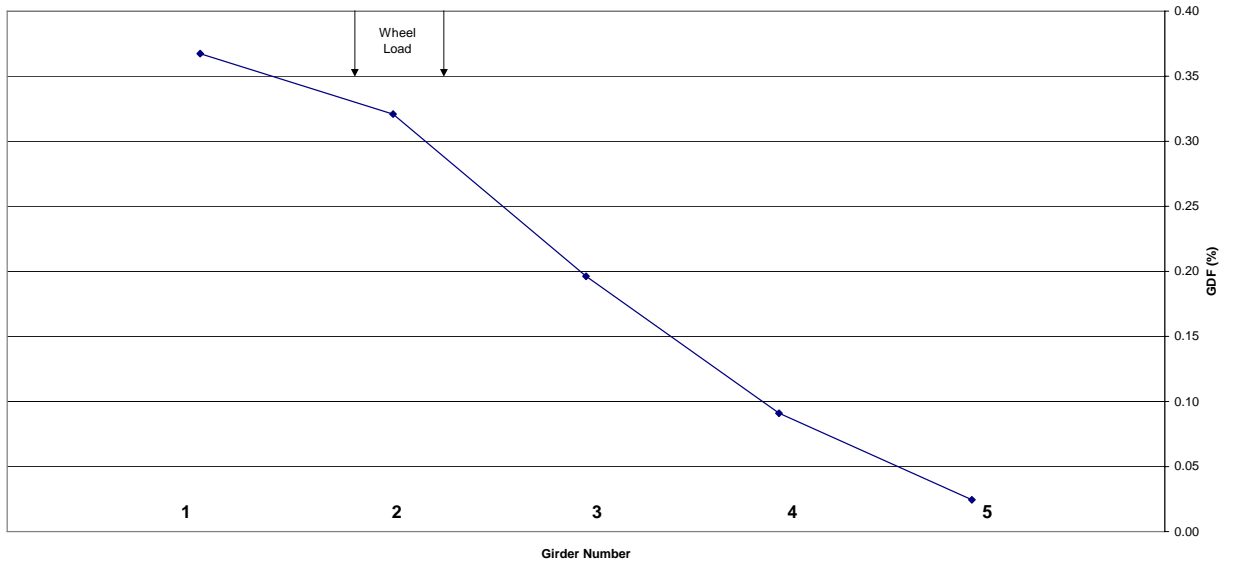
**Figure 2.9: Longitudinal Gage Position of DuPont Access Girder**



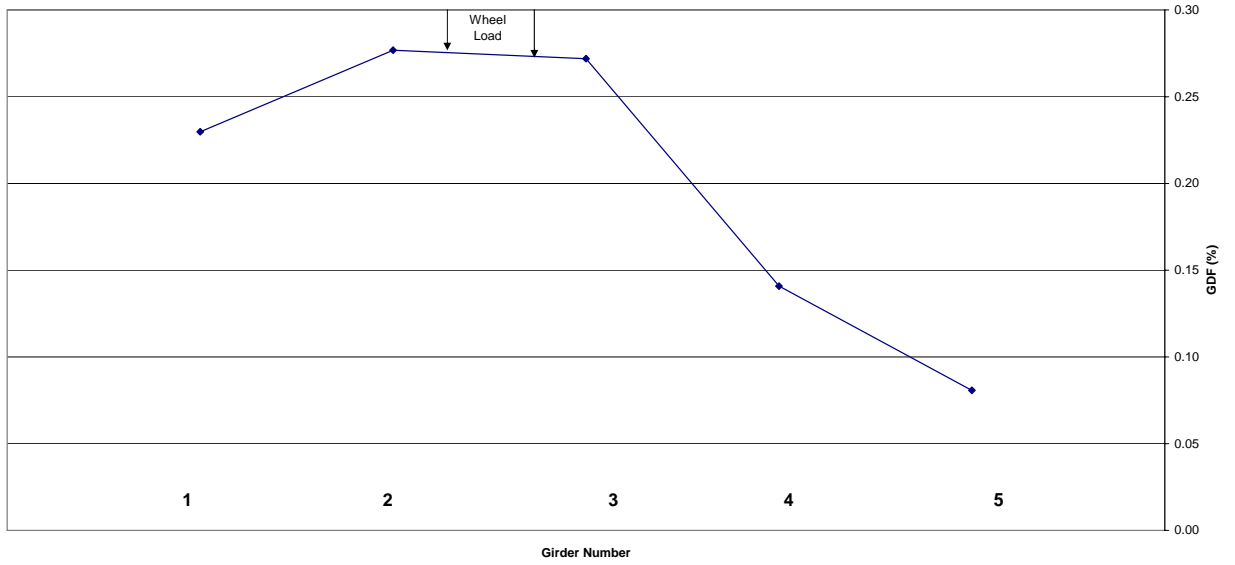
**Figure 2.10: Cross Section of DuPont Access Girder with Gage Position**



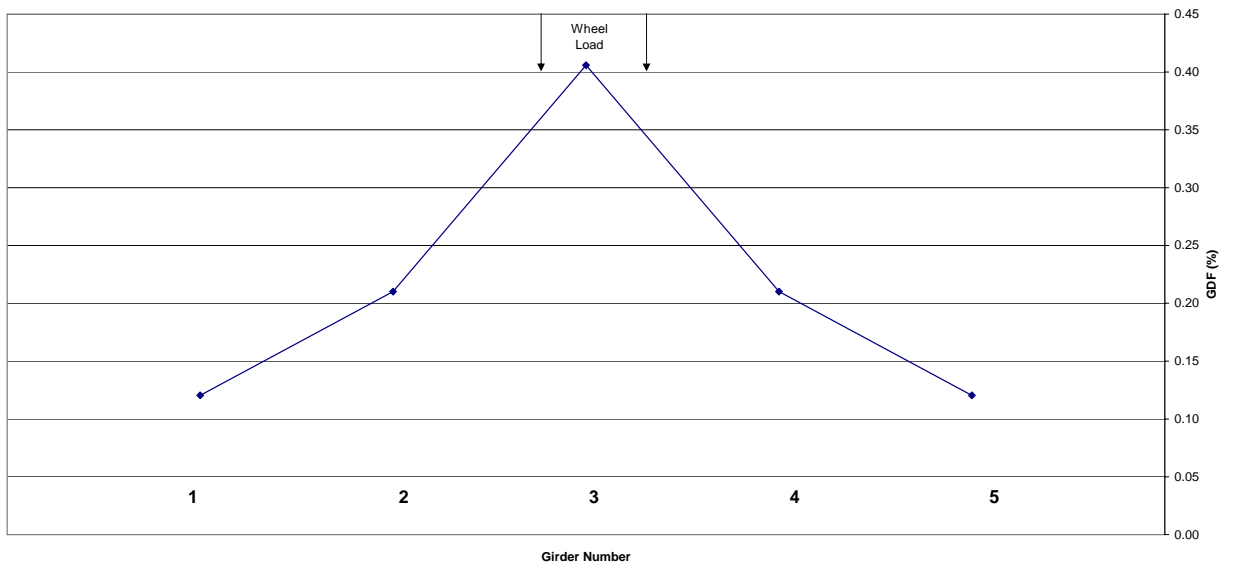
**Figure 2.11: Massman Drive Load Distribution Factors for Load Between Girders 1 and 2 (Positive Moment)**



**Figure 2.12: Massman Drive Load Distribution Factors for Load Over Girder 2 (Positive Moment)**

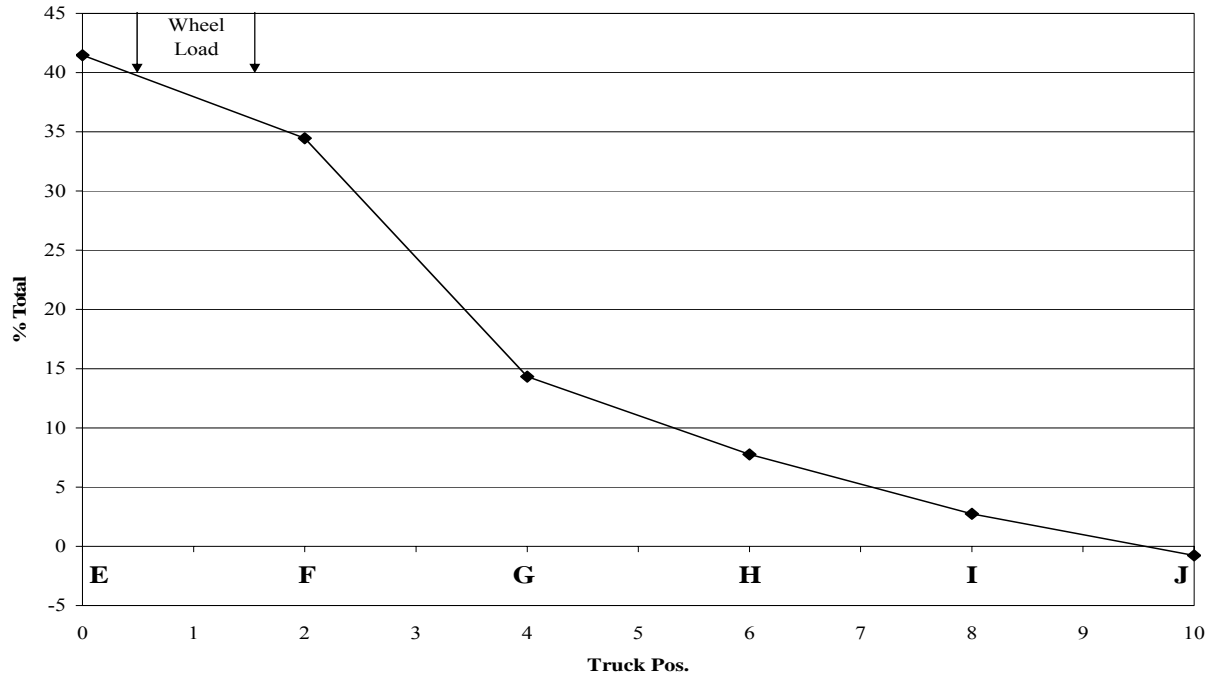


**Figure 2.13: Massman Drive Load Distribution Factors for Load Between Girders 2 and 3 (Positive Moment)**

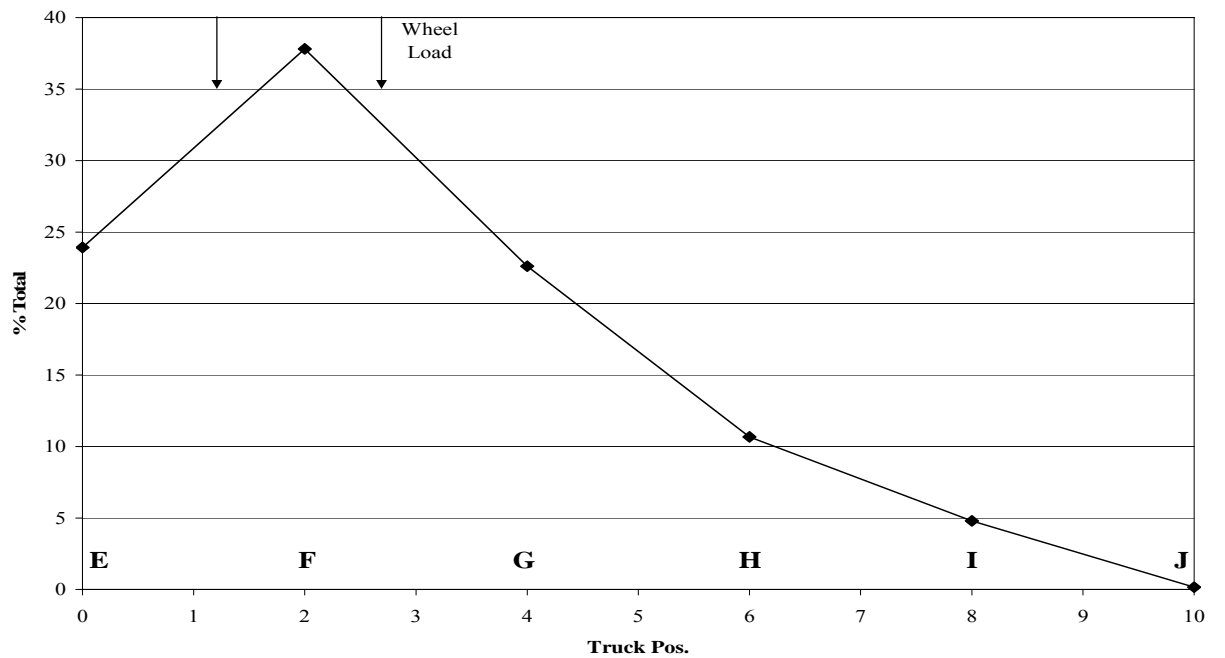


**Figure 2.14: Massman Drive Load Distribution Factors for Load Over Girder 3 (Positive Moment)**

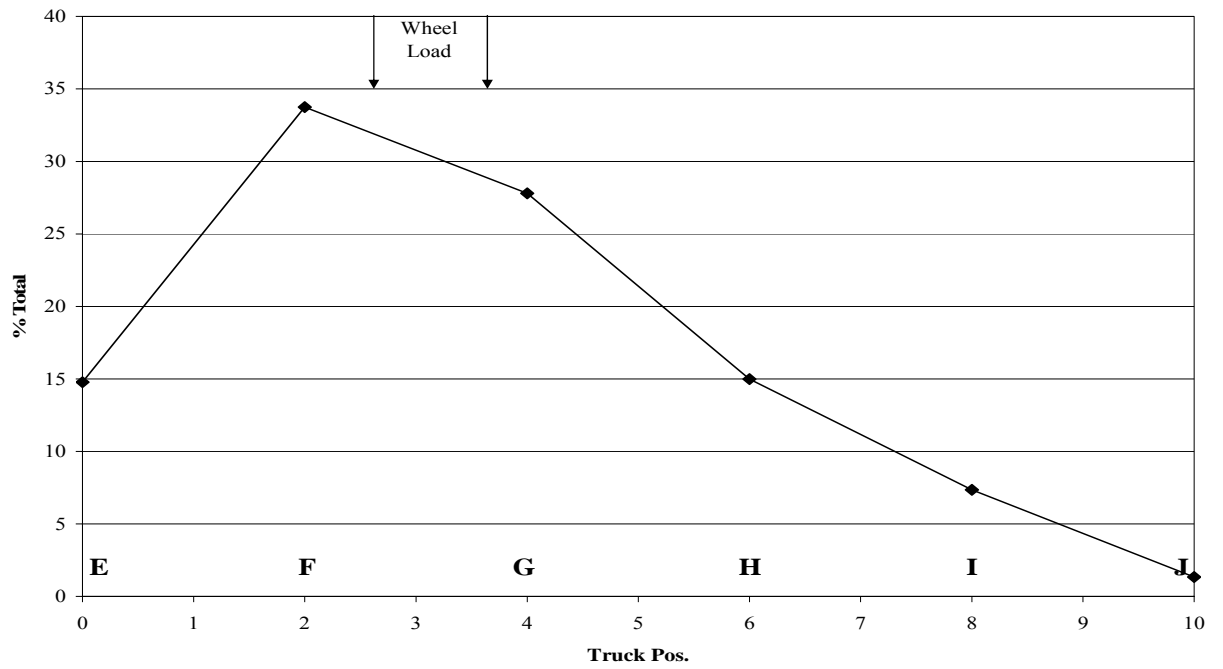




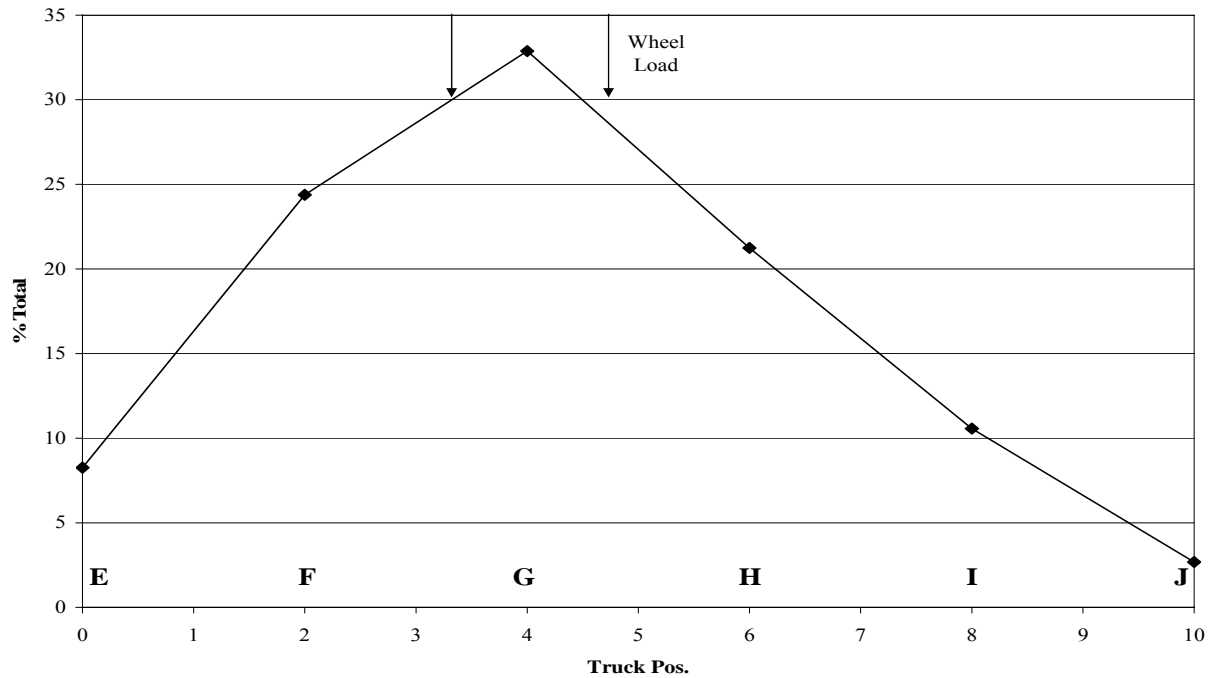
**Figure 2.15: DuPont Access Load Distribution Factors for Load Between Girders E and F (Positive Moment)**



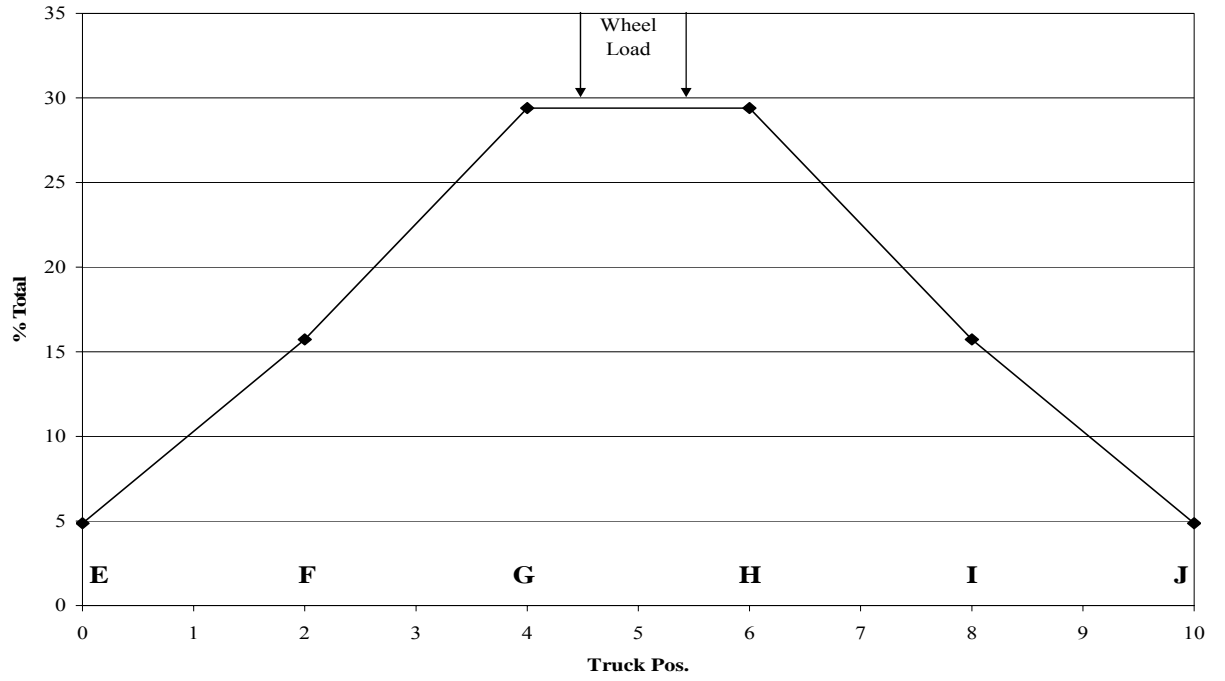
**Figure 2.16: DuPont Access Load Distribution Factors for Load Over Girder F (Positive Moment)**



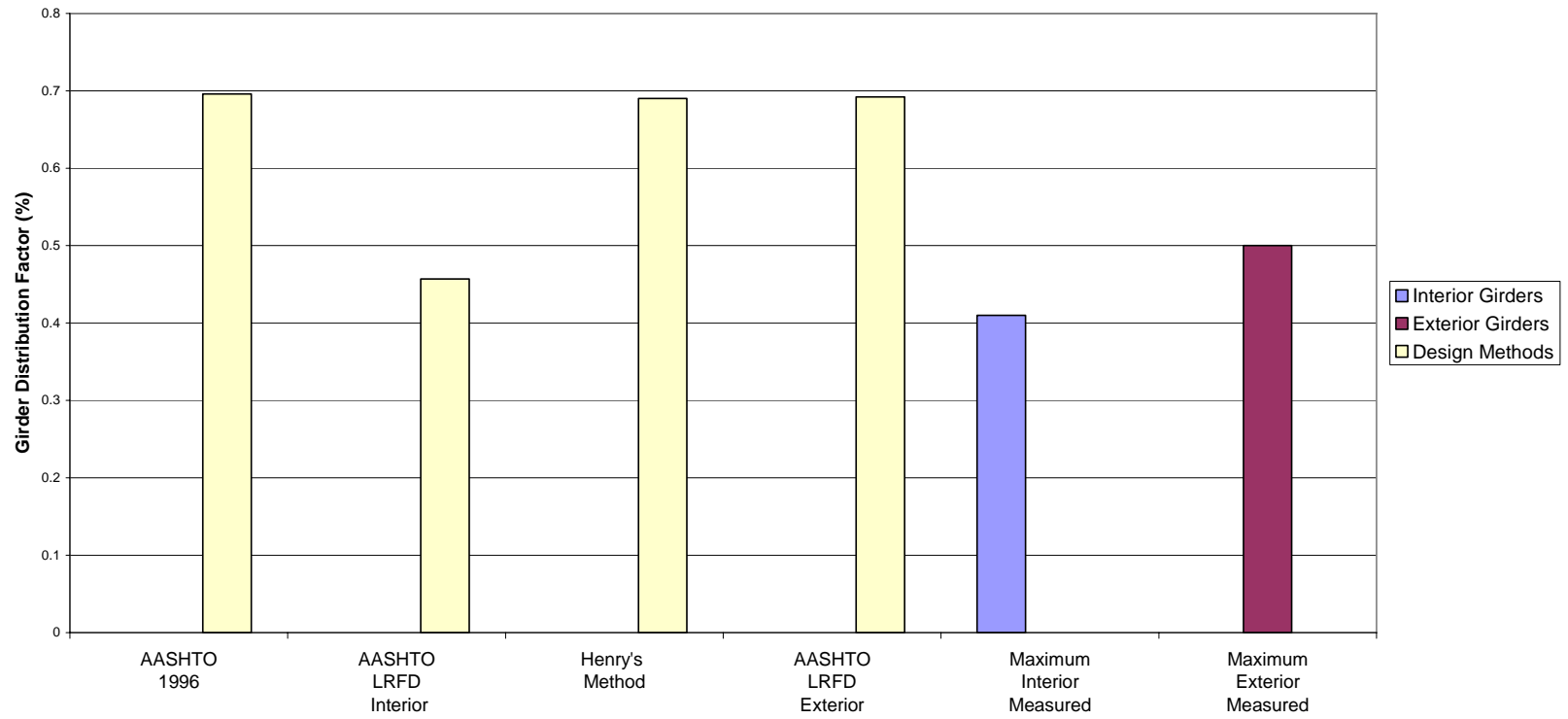
**Figure 2.17: DuPont Access Load Distribution Factors for Load Between Girders F and G (Positive Moment)**



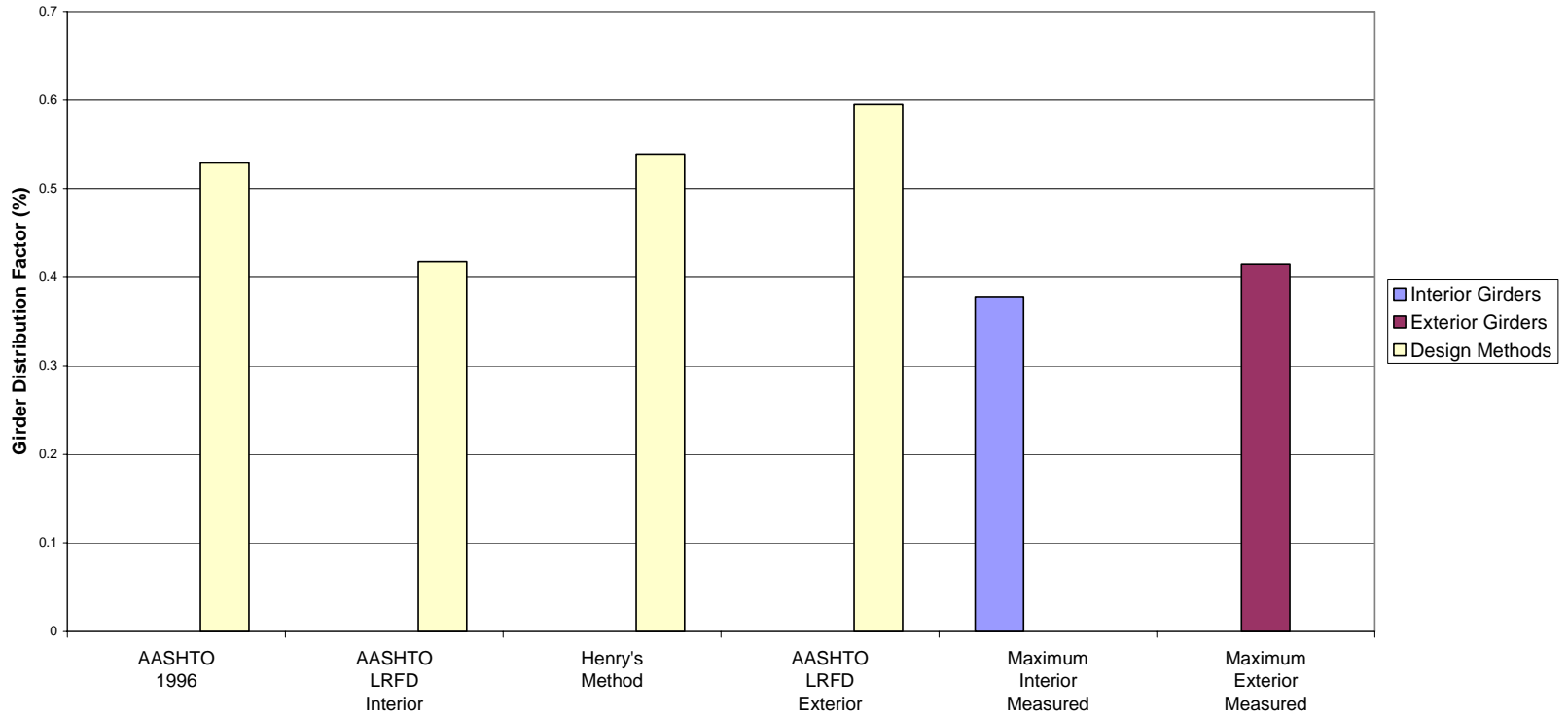
**Figure 2.18: DuPont Access Load Distribution Factors for Load Over Girder G (Positive Moment)**



**Figure 2.19: DuPont Access Load Distribution Factors for Load Between Girders G and H (Positive Moment)**



**Figure 20: Comparison of GDF's for Massman Drive Bridge**



**Figure 21: Comparison of GDF's for DuPont Access Bridge**

## **VITA**

Kyle Parker Scoble was born in Peru, IN on April 1, 1984. He was raised in Murfreesboro, TN and graduated from Oakland High School in 2002. From there, he went to the University of Tennessee, Knoxville and received a B.A. in Civil Engineering in 2006 and a M.A. in Civil Engineering with an emphasis in Construction in 2007. Kyle is currently pursuing his career in construction project management.