



8-2009

Foraging Behavior of *Nerodia clarkii compressicauda*, with Special Reference to Lingual Luring

Kerry Andrew Hansknecht
University of Tennessee - Knoxville

Follow this and additional works at: https://trace.tennessee.edu/utk_graddiss



Part of the [Ecology and Evolutionary Biology Commons](#)

Recommended Citation

Hansknecht, Kerry Andrew, "Foraging Behavior of *Nerodia clarkii compressicauda*, with Special Reference to Lingual Luring. " PhD diss., University of Tennessee, 2009.
https://trace.tennessee.edu/utk_graddiss/40

This Dissertation is brought to you for free and open access by the Graduate School at TRACE: Tennessee Research and Creative Exchange. It has been accepted for inclusion in Doctoral Dissertations by an authorized administrator of TRACE: Tennessee Research and Creative Exchange. For more information, please contact trace@utk.edu.

To the Graduate Council:

I am submitting herewith a dissertation written by Kerry Andrew Hansknecht entitled "Foraging Behavior of *Nerodia clarkii compressicauda*, with Special Reference to Lingual Luring." I have examined the final electronic copy of this dissertation for form and content and recommend that it be accepted in partial fulfillment of the requirements for the degree of Doctor of Philosophy, with a major in Ecology and Evolutionary Biology.

Gordon M. Burghardt,, Major Professor

We have read this dissertation and recommend its acceptance:

James A. Fordyce, Todd M. Freeberg, Neil Greenberg, Nathan J. Sanders

Accepted for the Council:

Carolyn R. Hodges

Vice Provost and Dean of the Graduate School

(Original signatures are on file with official student records.)

To the Graduate Council:

I am submitting herewith a dissertation written by Kerry Andrew Hansknecht entitled “Foraging Behavior of *Nerodia clarkii compressicauda*, with Special Reference to Lingual Luring.” I have examined the final electronic copy of this dissertation for form and content and recommend that it be accepted in partial fulfillment of the requirements for the degree of Doctor of Philosophy, with a major in Ecology and Evolutionary Biology.

Gordon M. Burghardt, Major Professor

We have read this dissertation
and recommend its acceptance:

James A. Fordyce

Todd M. Freeberg

Neil Greenberg

Nathan J. Sanders

Accepted for the Council:

Carolyn R. Hodges
Vice Provost and Dean of the Graduate School

(Original signatures are on file with official student records.)

**FORAGING BEHAVIOR OF *NERODIA CLARKII COMPRESSICAUDA*, WITH
SPECIAL REFERENCE TO LINGUAL LURING**

A Dissertation Presented for
the Doctor of Philosophy
Degree
The University of Tennessee, Knoxville

Kerry Andrew Hansknecht
August 2009

Copyright © 2009 by Kerry Andrew Hansknecht
All rights reserved.

DEDICATION

To all of my snakes who, for some 11 years now, have tolerated my poking and prodding and grabbing and squeezing and staring at you while you ate. I forgive you for all of those bites (the defecating, not so much).

ACKNOWLEDGMENTS

An endeavor such as this is not undertaken alone. Even the most solitary individuals require, request, and receive help during the quest for an advanced degree. Throughout my academic upbringing, I have benefited from the assistance, support, and advice of many people. From the most recent stage in my career, I wish to thank first Dr. Gordon Burghardt, my advisor and committee chair. Gordon has been very generous in sharing his many resources (including space, equipment, funding, patience, and excellent homemade hot sauces!), and he has always been a very strong advocate. His vast experience and seemingly limitless memory were of considerable benefit to me during my time in his lab. I would also like to thank the other members of my committee, Neil Greenberg, Todd Freeberg, Jim Fordyce, and Nate Sanders, for their input and their friendly support. All five of these very bright and interesting people provided much more than just advice regarding my research. They have shown me what it takes to survive in academia, to be a smart and successful researcher (and person), and to be a good mentor and advisor. I can only hope to live up to their exemplary standards.

I am most grateful to Elizabeth McDonald, who has helped me in so many ways. I look forward to spending the remainder of my life with her, wherever our lives may lead us. I would also like to thank Lisa's parents, Bert and Ron. I look forward to many more vacations with them (but no more moves, I promise).

I want to give special thanks to two of the best friends a person could want. Mark Alston and Rick Nuhn have been around for me on more occasions than I can count. Thanks for having my back, gents.

Thanks to my academic mentors and siblings for helping me along the way. Carl Ernst and his graduate students did much to get me started. Thanks Thomas Wilson, Thomas Akre, Thomas Leuteritz, Terry Creque, and Tim Brophy. From there, Jim Gillingham provided me with a place learn more about behavior and anatomy, and I very much enjoyed my time in his lab with Wooten, Bowen, Moore, and the rest of the CMU gang. Paul Andreadis and Mark Waters have provided me much advice and encouragement over the years, and I am very happy to be part of their academic family. Here's hoping it continues to grow as we bring up our own students!

ABSTRACT

Predators use a variety of tactics with which to obtain prey. Here, I describe lingual luring by the mangrove saltmarsh snake (*Nerodia clarkii compressicauda*), a somewhat unique behavior that involves the use of the tongue to attract fish prey close enough to permit their capture. The lure is characterized by considerable upward curling of the distal portion of the tongue as it protrudes from the mouth. In addition, luring tongue flicks are significantly greater in duration than chemosensory tongue flicks. Both visual and chemical cues are sufficient to stimulate lingual luring, the latter more so than the former. However, both types of cues together have a strong synergistic effect on elicitation of the behavior. Luring behavior presents primarily a visual stimulus, as its frequency was reduced in the dark. Although prey density had no effect on the exhibition of luring by these snakes, prey density did have an effect on their activity level and their choice of foraging sites. *N. c. compressicauda* was a fairly active forager under the conditions tested in these studies, but its use of a largely sit-and-wait tactic such as predatory luring indicates that this species uses more of a mixed foraging strategy. The foraging behavior of the snakes differed at different levels of habitat structural density, created by using simulated prop roots in a laboratory arena. When no prop-root structure was present, the snakes rarely ventured into open water. However, they spent significantly more time in the water if prop roots were present. Such habitat structure may serve as protection from larger predators that may be impeded by it.

TABLE OF CONTENTS

INTRODUCTION	1
PART 1. LINGUAL LURING BY MANGROVE SALTMARSH SNAKES (<i>NERODIA CLARKII COMPRESSICAUDA</i>)	3
Abstract	4
Introduction.....	4
Method	6
Results.....	8
Description of the Behavior	8
Context and Efficacy of Luring Tongue Flicks	9
Exhibition of Luring Tongue Flicks relative to Fish Presence	10
Comparison between Durations of Luring Tongue Flicks and Normal Tongue Flicks	11
Discussion.....	11
Literature Cited.....	16
Appendix 1.....	20
PART 2. STIMULUS CONTROL OF LINGUAL PREDATORY LURING AND RELATED FORAGING TACTICS OF MANGROVE SALTMARSH SNAKES (<i>NERODIA CLARKII COMPRESSICAUDA</i>).....	24
Abstract.....	25
Introduction.....	25
Method	28

Subjects	28
Apparatus	28
Stimuli.....	29
Procedure	30
Data Collection and Analysis.....	31
Results.....	32
Number of Luring Tongue Flicks (LTF)	32
Number of Attacks	32
Percent Time Moving (PTM).....	33
Movements Per Minute (MPM).....	33
Percent Time near Front (PTF)	34
Discussion	34
Literature Cited	39
Appendix 2.....	45
PART 3. EFFECTS OF ECOLOGICAL VARIABLES ON THE FORAGING	
BEHAVIOUR OF MANGROVE SALTMARSH SNAKES (<i>NERODIA CLARKII</i>	
<i>COMPRESSICAUDA</i>)	
Abstract.....	53
Introduction.....	54
Experiment I: The Influence of Prey Density	59
Method	59
Results.....	62
Discussion.....	63

Experiment II: The Influence of Habitat Structure	64
Method	64
Results.....	66
Discussion.....	67
Experiment III: The Influence of Light Intensity	69
Method	69
Results.....	72
Discussion.....	74
Literature Cited.....	78
Appendix.....	86
CONCLUSION.....	104
VITA.....	105

LIST OF TABLES

PART 2.

Table 2. 1. Effect size estimates of differences in luring tongue flick (LTF) and attack responses by mangrove saltmarsh snakes (*Nerodia clarkii compressicauda*) to different prey stimulus treatments. 46

PART 3.

Table 3. 1. Results of statistical analyses of five measures of activity within the test arena compared among the three different treatments in Experiment II. Subjects were 24 mangrove saltmarsh snakes (*Nerodia clarkii compressicauda*) observed in the presence of three guppies (*Poecilia reticulata*) at three simulated prop-root density levels (0 m⁻², 30 m⁻², and 60 m⁻²). Values in bold indicate statistically significant differences among the three treatments at the 0.05 level. 87

Table 3. 2 Results of statistical analyses comparing time spent in the different parts of the test arena among the different simulated prop root densities in Experiment II. Subjects were 24 mangrove saltmarsh snakes (*Nerodia clarkii compressicauda*) observed in the presence of three guppies (*Poecilia reticulata*) at three prop-root density levels (0 m⁻², 30 m⁻², and 60 m⁻²). Values in bold indicate statistically significant differences among the three treatments at the 0.05 level. 88

Table 3. 3 Results of statistical analyses of measures related to interactions between 24 mangrove saltmarsh snakes (*Nerodia clarkii compressicauda*) and guppies (*Poecilia reticulata*) at three prop-root density levels (0 m⁻², 30 m⁻², and 60 m⁻²) in Experiment II. No statistically significant differences were revealed in the analyses. 89

LIST OF FIGURES

PART 1.

- Figure 1. 1. (A–D) Sequence of noteworthy points in the protraction phase of a luring tongue flick by *Nerodia clarkii compressicauda*. (E) Lateral deflection of the tongue during the luring phase. (F–H) Attraction of fish toward the tongue during the luring phase. Images are unaltered except for cropping and global changes to size, brightness, and contrast. The retraction phase (not shown) follows the luring phase and involves uncurling of the terminal loop as the tongue is withdrawn into the mouth. 21
- Figure 1. 2. Frequency distribution of latencies of luring tongue flicks exhibited by eight juvenile *Nerodia clarkii compressicauda* during 30-minute individual observation periods. Each snake was alone in a feeding chamber during the first 10 minutes of the observation period. Four guppies (*Poecilia reticulata*) were added to the feeding chamber 10 minutes after observations began. 22
- Figure 1. 3. Frequency distribution of durations of normal tongue flicks ($N = 188$) and luring tongue flicks ($N = 188$) exhibited by 19 neonate and juvenile *Nerodia clarkii compressicauda*. Different bin widths are used below (0.1 seconds) and above (2 seconds) the gap on the x-axis to prevent variation in normal tongue-flick duration from being hidden within a single bar. 23

PART 2.

- Figure 2. 1. The test arena used for stimulus-control experiments involving chemical and visual cues. The circular structure on the right was added after the present experiments were completed. 47

Figure 2. 2. Mean number of luring tongue flicks (\pm 95 % CI) exhibited by ingestively naïve neonate mangrove saltmarsh snakes (*Nerodia clarkii compressicauda*) in the presence of four different prey stimulus treatments. Means that do not share superscribed letters are significantly different from each other..... 48

Figure 2. 3. Mean number of attacks (\pm 95 % CI) exhibited by ingestively naïve neonate mangrove saltmarsh snakes (*Nerodia clarkii compressicauda*) in the presence of four different prey stimulus treatments. Means that do not share superscribed letters are significantly different from each other..... 49

Figure 2. 4. Mean percent time (\pm 95 % CI) spent moving by ingestively naïve neonate mangrove saltmarsh snakes (*Nerodia clarkii compressicauda*) in the presence of four different prey stimulus treatments. Means that do not share superscribed letters are significantly different from each other..... 50

Figure 2. 5. Mean number of movements per minute (\pm 95 % CI) made by ingestively naïve neonate mangrove saltmarsh snakes (*Nerodia clarkii compressicauda*) in the presence of four different prey stimulus treatments. 51

Figure 2. 6. Mean percent time (\pm 95 % CI) spent in the anterior 1/3rd of the test arena (nearest the visual stimulus) by ingestively naïve neonate mangrove saltmarsh snakes (*Nerodia clarkii compressicauda*) in the presence of four different prey stimulus treatments. 52

PART 3.

Figure 3. 1. Cartoon of the test arena used for experiments examining the effects of prey density (A) and habitat structural density (B) on foraging behaviour of mangrove saltmarsh snakes (*Nerodia clarkii compressicauda*) in Experiments I and II,

respectively. The top-down view (C) and legend indicate the approximate positions of land, shore, and open water areas. Not drawn to scale. See text for dimensions. 90

Figure 3. 2. Percent of time spent moving (PTM; mean \pm 95% CI) by mangrove saltmarsh snakes (*Nerodia clarkii compressicauda*) in the presence of prey guppies (*Poecilia reticulata*) at three different levels of prey density (Low = 2.6 m⁻²; Medium = 13 m⁻²; High = 65 m⁻²) in Experiment I. Means that do not share superscribed letters are significantly different from each other..... 91

Figure 3. 3. Mean (\pm 95% CI) number of luring tongue flicks (open circles), attacks (closed circles), and captures (open squares) by mangrove saltmarsh snakes (*Nerodia clarkii compressicauda*) in the presence of prey guppies (*Poecilia reticulata*) at three different levels of prey density (Low = 2.6 m⁻²; Medium = 13 m⁻²; High = 65 m⁻²) in Experiment I. 92

Figure 3. 4. Percent of time spent moving (PTM; mean \pm 95% CI) in open water by 24 mangrove saltmarsh snakes (*Nerodia clarkii compressicauda*) observed in the presence of three guppies (*Poecilia reticulata*) at three prop-root density levels (0 m⁻², 30 m⁻², and 60 m⁻²) in Experiment II. Means that do not share superscribed letters are significantly different from each other..... 93

Figure 3. 5. Percent of time spent in open water (mean \pm 95% CI) among three levels of habitat structural complexity. Subjects were 24 mangrove saltmarsh snakes (*Nerodia clarkii compressicauda*) observed in the presence of three guppies (*Poecilia reticulata*) at three prop-root density levels (0 m⁻², 30 m⁻², and 60 m⁻²) in Experiment II. Means that do not share superscribed letters are significantly different from each other. 94

Figure 3. 6. Mean (\pm 95% CI) duration of visits to open water among three levels of habitat structural complexity. Subjects were 24 mangrove saltmarsh snakes (*Nerodia clarkii compressicauda*) observed in the presence of three guppies (*Poecilia reticulata*) at three prop-root density levels (0 m^{-2} , 30 m^{-2} , and 60 m^{-2}) in Experiment II..... 95

Figure 3. 7. Numbers (mean \pm 95% CI) of encounters (within 6 cm; open circles), attacks (closed circles), luring tongue flicks (open squares), and captures (closed squares) involving individual mangrove saltmarsh snakes (*Nerodia clarkii compressicauda*; N = 24) and three guppies (*Poecilia reticulata*) at three prop-root density levels (Low, 0 m^{-2} ; Medium, 30 m^{-2} ; and High, 60 m^{-2}) in Experiment II..... 96

Figure 3. 8. Cartoon of the test arenas used in Experiment III for experiments examining the effects of light intensity on foraging behaviour of mangrove saltmarsh snakes (*Nerodia clarkii compressicauda*). Not drawn to scale. See text for dimensions..... 97

Figure 3. 9. Number of six-month-old mangrove saltmarsh snakes (N = 9) exhibiting luring tongue flicks (LTFs) in the presence of fish prey at each of four different light intensities in Experiment III..... 98

Figure 3. 10. Mean (\pm 95% CI) number of luring tongue flicks (LTFs) exhibited by six-month-old mangrove saltmarsh snakes (N = 9) in the presence of fish prey at each of four different light intensities in Experiment III..... 99

Figure 3. 11. Mean (\pm 95% CI) number of attacks exhibited by six-month-old mangrove saltmarsh snakes (N = 9) in the presence of fish prey at each of four different light intensities in Experiment III..... 100

Figure 3. 12. Number of 18-month-old mangrove saltmarsh snakes (N = 15) exhibiting luring tongue flicks (LTFs) in the presence of fish prey at each of four different light intensities in Experiment III..... 101

Figure 3. 13. Mean (\pm 95% CI) number of luring tongue flicks (LTFs) exhibited by 18-month-old mangrove saltmarsh snakes (N = 15) in the presence of fish prey at each of four different light intensities in Experiment III. 102

Figure 3. 14. Mean (\pm 95% CI) number of attacks exhibited by 18-month-old mangrove saltmarsh snakes (N = 15) in the presence of fish prey at each of four different light intensities in Experiment III..... 103

INTRODUCTION

Foraging is one of the more important tasks with which organisms are burdened. Given the importance of finding food, it is no surprise that a bewildering array of interesting adaptations has arisen that serve to improve an organism's chances of successful location and consumption of other, less fortunate, ones. Predatory luring is one such kind of behavior. Although extremely widespread, and known by humans as far back in history as Aristotle, the luring of prey remains a poorly known phenomenon.

In this dissertation, I describe an interesting form of predatory luring exhibited by a small piscivorous snake that lives in red mangrove forests of southeastern North America. In addition to describing this behavior in detail, I present my experimental investigations of the influence of various stimuli and abiotic factors on the exhibition of the luring as well as other foraging behaviors, which are of course just as important.

In Part 1, I provide a description of lingual luring by *Nerodia clarkii compressicauda* and present evidence in support of its function as an effective luring device. In Part 2, I examine the importance of chemical and visual stimuli to the elicitation of lingual luring, eliminating tactile stimuli completely by using digital video of fish as one of the prey cues. In addition, I include some observations of the activity levels of the snakes in the presence of these cues, and make some inferences about when and where this behavior might occur in nature. In Part 3, I continue my investigation of the luring by examining the effects of prey density on the luring behavior as well as other foraging behaviors that may be influenced by the availability of prey. Ecological variables such prey density can lead predators to alter the way they forage, causing them to switch from being active

predators to more sedentary ones. I move on to look at the effects of habitat structure on this snakes foraging behavior. Mangrove forests are replete with structure, the prop roots of their dominant species providing an excellent home for juvenile fishes to grow up away from larger fish predators. However, too much structural complexity can interfere with a predator's ability to see and pursue their quarry. Finally, I examine the effects of light intensity on the use of lingual luring by these snakes. Mangrove saltmarsh snakes are reputedly nocturnal animals, while the lingual luring seems as though it may present primarily visual stimuli to its target. Throughout this work, I make connections between this interesting behavior and others and the ecology of this poorly known organism.

**PART 1. LINGUAL LURING BY MANGROVE SALTMARSH SNAKES
(*NERODIA CLARKII COMPRESSICAUDA*)**

This part is a version of a paper by the same name published in the journal *Journal of Herpetology* in 2008 by Kerry A. Hansknecht:

Hansknecht, K. A. 2008. Lingual Luring by Mangrove Saltmarsh Snakes (*Nerodia clarkii compressicauda*). *Journal of Herpetology* 42:9-15.

Abstract

Very few cases of predatory luring by squamate reptiles involve body parts other than the tail. Here I report the use of the tongue by Mangrove Saltmarsh Snakes (*Nerodia clarkii compressicauda*) to lure prey, a behavior thus far adequately described for only one other snake species. Fishes are the only verified component of the diet of these snakes and are effectively attracted by the luring behavior. Lingual luring by these snakes is particularly unique in that the tongue is curled upon itself distally such that a conspicuous loop is formed at its terminus. The rapid oscillations typical of chemosensory tongue flicks are absent, though the terminal loop does exhibit some vertical and horizontal movement. The duration of luring tongue flicks is significantly greater than the duration of chemosensory tongue flicks.

Introduction

Predatory luring is a means of nutrient acquisition in which one organism (the predator) produces a stimulus that is attractive to another organism (the prey) that is consumable, in whole or in part, to the predator. This often occurs in the form of aggressive mimicry (Wickler, 1968; Vane-Wright, 1976; Pasteur, 1982; Pough, 1988) or feeding mimicry (Schuett et al., 1984) in which a deceptive signal transmitted by the predator (the mimic) resembles a stimulus produced by an entity (the model) that the prey (the dupe) would normally approach. In successful predatory luring, potential prey perceive the attractive stimulus and approach the predator more closely than they might in the absence of that stimulus. This may or may not result in capture and consumption of

attracted prey in a given instance, but it should do so at least occasionally (Dawkins and Krebs, 1978).

Predatory luring by nonavian reptiles is widely reported and is exhibited by members of several groups therein (Neill, 1960; Drummond and Gordon, 1979; Murray et al., 1991). The most common form of predatory luring among reptiles is caudal luring, which is exhibited primarily by snakes and involves motions of the tail tip that cause it to resemble a generalized invertebrate larva suitable as prey for frogs and lizards (Pough, 1988). Predatory luring by reptiles is also achieved through the use of the tongue (i.e., lingual luring), but the taxa involved are few. The most well known example of lingual luring comes from the Alligator Snapping Turtle (*Macrochelys temminckii*), which possesses a bifurcate, worm-like lingual appendage that attracts fish into its mouth (Drummond and Gordon, 1979; Spindel et al., 1987). Czaplicki and Porter (1974) reported lingual "fly-casting" by two watersnake species (*Nerodia sipedon* and *N. rhombifer*) that flicked the surface of the water with their tongue, causing fish to approach and be captured. However, as the focus of their study was not the luring, the authors' description of the behavior is limited. Some have speculated that the straight, rigid, long-lasting tongue protrusions exhibited by vine snakes (*Ahaetulla*, *Oxybelis*, *Thelotornis*, and *Uromacer*) serve to lure prey (Lillywhite and Henderson, 1993). However, Keiser (1975) provided an effective argument against such a function for this behavior as exhibited by *Oxybelis* and perhaps others, at least with respect to arboreal prey, and he found crypticity a more likely role. In addition, there is no evidence to date that those tongue protrusions are attractive to prey, a key component of predatory luring (Strimple, 1992). Recently, a more detailed and convincing account of lingual luring by a

snake was provided by Welsh and Lind (2000). They observed neonate and juvenile Aquatic Gartersnakes (*Thamnophis atratus*) quivering the tips of their tongues on the water's surface in streams where the snakes feed upon juvenile salmonid fishes. *Thamnophis atratus*' tongue protrusions during luring are of far greater duration than normal, investigative tongue flicks and are effective at attracting prey (Welsh and Lind, 2000).

Herein I describe lingual luring by another semiaquatic snake, the Mangrove Saltmarsh Snake (*Nerodia clarkii compressicauda*). These snakes are associated rather strictly with red mangrove (*Rhizophora mangle*) around the Atlantic and Gulf coasts of the southern half of Florida as well as northern coastal Cuba (Neill, 1965; Ernst and Ernst, 2003). Fish are the only known component of their diet (Miller and Mushinsky, 1990; Mullin and Mushinsky, 1995) and are the assumed target of the luring. This report involves a species not previously known to lure prey, and certain details of the luring behavior make it unique.

Method

My initial observations of apparent predatory lingual luring involved two captive-born one-year-old *N. c. compressicauda* (1F, 1M) that were obtained from a commercial supplier and whose parents had been captured at an unknown site in the Florida Keys. In order to examine the behavior further, I collected three *N. c. compressicauda*, one sub-adult (F) and two adults (1F, 1M), on northern Key Largo in March 1999. None of these wild-caught animals exhibited the putative luring in the three months following capture. Therefore, for the present laboratory study, I focused on 25 captive-bred young (< 1 yr

old), all descended from the original captive-born luring male and the two wild-caught females. Feeding sessions involving 19 of the offspring were videotaped and analyzed.

Videotaped feeding sessions were conducted on days when subjects were to be fed in accordance with their normal schedule (4–6 guppies every 5–7 days) in order to ensure sufficient and similar motivation to feed. On this schedule, young *N. clarkii* grow in good health and rarely refuse food. Subjects were videotaped individually in a 5.83-L plastic shoebox filled with tap water to a depth of 2 cm. A single 20-cm length of 1.7-cm diameter PVC tubing was partially submerged horizontally to provide an anchorage and ambush site for the subject. I added between three and six guppies (*Poecilia reticulata*) to the feeding chamber, usually before transfer of the subject from its home enclosure. Subjects were videotaped during multiple sessions for 15–20 minutes or until it became apparent that they had little interest in the fish (e.g., attempted to escape for several minutes). To determine how closely allied the putative luring was with the presence of fish, I made a small set of control observations using a litter of eight juveniles: During the second session of observations of these individuals, I videotaped the subjects alone in the chamber for 10 minutes before adding four guppies to the water. After the fish were added, I continued videotaped observations for an additional 20 minutes. The feeding chamber was rinsed thoroughly with tap water between each of these 30-minute observation periods.

Videotaped feedings were later examined carefully for instances of putative luring, and a qualitative means of distinguishing this from normal tongue flicking (Gove, 1979) was established. In order to make a quantitative comparison between normal tongue flicks (NTFs) and putative luring tongue flicks (LTFs), I measured the duration of each

LTF and an equal number of NTFs (one NTF chosen pseudorandomly from within ± 2 minutes of the start of each LTF) by counting video frames in which any part of the tongue was outside the mouth. After converting from number of frames to seconds, I calculated the mean durations of the two types of tongue flicks for each subject and used these means to compare the duration of LTFs to that of NTFs using a paired-samples *t*-test. I estimated the size of this difference effect by calculating Cohen's *d* using *t* in a formula that accounts for any correlation between paired measures (Dunlap et al., 1996, Eq. 3). The coefficient of variation (CV) served as a metric of inter-individual variability in mean duration of LTFs and NTFs. Spearman rank correlation was used to examine the relationship between the subjects' mean durations of LTFs and NTFs. Data were tested for normality using the method of D'Agostino et al. (1990) and for equality of variance using Levene's test.

Results

Description of the Behavior

The luring tongue flick of *Nerodia clarkii compressicauda* comprises three phases similar to the protrusion, oscillation, and retraction phases that Ulinski (1972) outlined for flick clusters (here referred to as tongue flicks, Gove, 1979), except the oscillation phase of a tongue flick is replaced by a luring phase. This luring phase, like the oscillation phase of Ulinski (1972), overlaps the protrusion and retraction phases. The protrusion and luring phases are most notably characterized by an immediate and persistent curling of the distal portion of the tongue. Upon leaving the margin of the mouth, the tongue tip bends upward and makes contact with the rostrum in the vicinity of

the junction between the rostral and internasal scales (Figure 1.1A); this is diagnostic of the behavior. Further protrusion of the tongue while its tip remains in contact with the rostrum results in the formation of a terminal loop (Figure 1.1B). The bifurcation point touches or nearly touches a slightly more proximal portion of the tongue, and the two tines are forced apart laterally. Remaining curled, the tip of the tongue then breaks contact with the rostrum as protrusion continues (Figure 1.1C–D). After some time, the tongue is retracted back into the mouth, the tip uncurling in the process.

During the protrusion and luring phases, some slow, low-amplitude vertical movement of the tongue usually occurs. During the luring phase, the completeness of the tongue loop is often decreased and increased alternately; this is tightly linked to the vertical movements. Lateral deflection (Ulinski, 1972) and twisting of the tongue will often also occur during the luring phase (Figure 1.1E), and in many cases the terminal tongue loop is bent toward fish in the vicinity. As one would expect, not every LTF is executed well. False starts occasionally occur whereby the tongue is retracted prematurely, before the terminal loop is completed or protruded beyond the snout. In other cases, the terminal loop remains stuck to the snout for part or all of the duration of the LTF. Also, near-complete uncurling occasionally occurs well before the onset of retraction, resulting in a protruded tongue only slightly upturned.

Context and Efficacy of Luring Tongue Flicks

All of the 25 subjects observed in this study exhibited LTFs. I observed the behavior only in the presence of fish, and it was often exhibited during a subject's first encounter with this prey. Subjects most often produced LTFs while in the water (96% of all LTFs) with their head either above (89%) or below (11%) the water's surface, though on a few

occasions (4% of all LTFs) the subject exhibited the behavior while perched atop the ambush tube. During many (33%) of the LTFs produced with only the head above the water, the terminal tongue loop made contact with the water's surface. Subjects were usually motionless for at least a short period (1–2 seconds or more) prior to initiating LTFs, and their entire body remained motionless while the tongue was protruded.

Fish often approached the subject's tongue during LTFs (Figure 1.1F–H), and attraction, though not quantified, seemed to me to be strongest when the terminal loop was deflected downward far enough to touch the surface of the water. On four videotaped occasions, a fish struck at and bit the tongue during the luring phase. In three of these four cases, the subject immediately struck at the fish, albeit unsuccessfully; in the fourth case, the subject did not respond. On 10 other videotaped occasions, the subject aborted an LTF and immediately struck at a nearby fish that had not bitten the tongue. Two of these 10 strikes resulted in capture of the fish, one of which was clearly attracted to and approaching the protruded, curled tongue of the subject at the time. In addition to this, one subject that was never videotaped also attracted and captured a fish once as a direct result of an LTF.

Exhibition of Luring Tongue Flicks relative to Fish Presence

During the 10-minute control observations of eight subjects with no fish present, no LTFs were observed. However, seven of the eight subjects exhibited LTFs after fish were added (Figure 1.2). Three of the subjects initiated LTFs almost immediately upon the addition of fish (12, 15, and 23 seconds afterward), and two others did so before 3.5 minutes had passed. Two of the three remaining subjects that exhibited LTFs, first doing so at 5.3 and 13.1 minutes post-addition, had captured fish earlier in the trial, necessarily

delaying the onset of the behavior for at least a short time during prey handling and swallowing.

Comparison between Durations of Luring Tongue Flicks and Normal Tongue Flicks

Videotaped observation sessions involving 19 of the 25 subjects yielded a total of 188 LTFs, which were analyzed along with an equal number of NTFs. The duration of NTFs ($N = 188$) ranged from 0.08 to 1.02 seconds, whereas LTFs lasted from 0.22 to 35.3 seconds (Figure 1.3). Subject mean durations of NTFs averaged 0.31 ± 0.033 seconds (mean \pm 95% CI, $N = 19$), while those of LTFs averaged 10.95 ± 2.31 seconds. These means differed significantly ($t_{18} = 9.70$, $P < 0.0001$), with an extremely large effect size ($d = 3.08$). Inter-individual variation in mean duration of LTFs ($CV = 43.82$) was nearly twice that of NTFs ($CV = 22.09$), and the variances of these two groups of means differed significantly (Levene's test, $F_{1,36} = 12.39$, $P = 0.0012$). Mean duration of LTFs was not significantly correlated with that of NTFs ($r_s = 0.042$, $df = 17$, $P = 0.864$).

Discussion

The unique tongue flicks described here likely do not function particularly to enhance chemosensation. Lingual taste buds are apparently absent in snakes (Morgans and Heidt, 1978; Young, 1997), so there should be no gustatory benefit to holding the tongue out of the mouth for long periods. One possible vomerolfactory benefit to lengthy protrusions might be an increase in the concentration of chemicals on the tongue, making weak chemical stimuli more detectable upon transfer to the vomeronasal organ (Keiser, 1975). If that were in operation, one would expect to see this behavior under almost any circumstance in which the collection of chemical information might be important, but this

has not been the case. Alternatively, these tongue flicks might function as an anti-predatory signal (Gove, 1979). While I did not explicitly test this hypothesis here, I have never observed this behavior in contexts that elicit defensive behaviors, such as musking (Gove, 1979; Gove and Burghardt, 1983). Contrary to both hypotheses, I have observed these tongue flicks only in the immediate context of foraging. This is exemplified by the control observations in the absence of fish, during which numerous normal flicks, but no tongue protrusions of the other type, were observed. As soon as prey were presented, however, the subjects began to exhibit frequently the prolonged, curled-tip tongue protrusions. The continued exhibition of normal tongue flicks during the period when fish were present suggests to me that a motivation to acquire chemical information existed but was not being satisfied, to notable extent anyway, by the lengthy, curled protrusions. When one also considers that fish are clearly attracted to these tongue movements, and that captures do result, it becomes apparent that this unique behavior functions primarily as a predatory lure.

The duration of luring tongue flicks exhibited by the *N. c. compressicauda* studied here appears to be somewhat greater than that of the *Thamnophis atratus* studied by Welsh and Lind (2000). However, the occurrence and extent of curling of the tongue tip of *N. c. compressicauda* are what make its lure particularly unique. The luring tongue flicks of *T. atratus* also significantly exceed its normal tongue flicks in duration, but its lure differs from the curling lure of *N. c. compressicauda* in that the tip of the tongue of *T. atratus* remains relatively straight and quivers (Welsh and Lind, 2000). Furthermore, the *T. atratus* tongue apparently always touches the water during luring, while the *N. c. compressicauda* tongue did so only some of the time here. Despite these differences,

which may or may not be trivial, the luring tongue flicks of both species occur in the same context (sensu Gove and Burghardt, 1983) and are effective in attracting prey.

The specific function of the terminal loop was not directly studied here and is thus unknown, but it may simply be to increase the conspicuousness of the luring tongue flicks. The curling might additionally make the tongue resemble, via semi-abstract mimicry (Pasteur, 1982; Pough, 1988), any number of invertebrates that are preyed upon by fishes in the mangroves. The formation of the terminal loop causes the two tongue tines to point divergently, and this may make the lure even more conspicuous and possibly increase the tongue's resemblance to an invertebrate by simulating antennae, cerci, or other appendages.

Caudal luring is exhibited almost exclusively by neonate and juvenile snakes, but adults of four species have been observed using their tail in a manner attractive to prey (Greene and Campbell, 1972; Heatwole and Davison, 1976; Carpenter et al., 1978; Jackson and Martin, 1980). Greene and Campbell (1972) and Heatwole and Davison (1976) hypothesize that cessation of luring behavior may be related to ontogenetic diet shifts, and they point out that those species that do lure as adults do not change their diet with age. *Thamnophis atratus* undergo an ontogenetic shift in prey type, and lingual luring in that species is exhibited only by neonates and juveniles (Welsh and Lind, 2000). *Nerodia clarkii compressicauda* eat only fish throughout life, with an ontogenetic diet shift that is chiefly restricted to changes in the relative proportions of smaller and larger fishes (Miller and Mushinsky, 1990). One would thus expect that their lingual luring might continue into adulthood. One adult *N. c. compressicauda*, the original captive-born male, was observed occasionally throughout its life in a feeding chamber similar to the

one used to collect the data analyzed here. This individual exhibited lingual luring well into adulthood, as late as five years of age. Like the observations of caudal luring by adult snakes, which are limited to one or a few individuals (Greene and Campbell, 1972; Heatwole and Davison, 1976; Carpenter et al., 1978; Jackson and Martin, 1980), my observation of lingual luring by one adult *N. c. compressicauda* indicates only that the behavior may occasionally be exhibited by adults. It remains to be seen whether or not adults exhibit predatory luring nearly as often as do neonates and juveniles. An ontogenetic change in prey size (Miller and Mushinsky, 1990) or an experience-related increase in prey capture skills (Krause and Burghardt, 2001) could eliminate any advantage the lingual luring might provide. In addition to such possible correlates of aging, a limited adjustment to captivity (Ford, 1995) may also have contributed to the absence of lingual luring among the three wild-caught snakes examined in 1999.

All of the young snakes used for this study belonged to the same paternal family, a fact that limits the validity of my findings considerably. This is partly improved upon by stimulus-control experiments currently underway that involve subjects born to several wild-caught females that were already pregnant at the time of capture. Most of these offspring have lured during the few observation sessions completed thus far (K. A. Hansknecht, unpubl. data), but these new subjects also originated from the Florida Keys. A study of possible geographic variation in the foraging behavior of *N. clarkii* is now in progress and draws from populations elsewhere in the species' distribution. Until such work is completed, one can conclude only that lingual luring is exhibited by at least some individual *N. c. compressicauda* in the southernmost populations.

The use of captive-reared animals for this study enabled me to control the environment experienced by my subjects. All subjects were isolated upon birth, and many of them exhibited lingual luring the first time they encountered potential prey. It is therefore clear that learning is not required for this behavior to occur, at least among members of the populations studied by me thus far. Despite this, I found considerable variation among individuals in mean duration of luring tongue flicks. Whether or not such variation is heritable awaits investigation.

Literature Cited

- Carpenter, C. C., J. B. Murphy, and G. C. Carpenter. 1978. Tail luring in the death adder, *Acanthophis antarcticus* (Reptilia, Serpentes, Elapidae). *Journal of Herpetology* 12:574-577.
- Czaplicki, J. A., and R. H. Porter. 1974. Visual cues mediating the selection of goldfish (*Carassius auratus*) by two species of *Natrix*. *Journal of Herpetology* 8:129-134.
- D'Agostino, R. B., A. Belanger, and R. B. D'Agostino, Jr. 1990. A suggestion for using powerful and informative tests of normality. *The American Statistician* 44:316-321.
- Dawkins, R., and J. R. Krebs. 1978. Animal signals: Information or manipulation. *In* J. R. Krebs and N. B. Davies (eds.), *Behavioural Ecology: An Evolutionary Approach*. 1st ed., pp. 282-309. Sinauer Associates, Sunderland, MA.
- Drummond, H., and E. R. Gordon. 1979. Luring in the neonate alligator snapping turtle (*Macroclemys temminckii*): Description and experimental analysis. *Zeitschrift für Tierpsychologie* 50:136-152.
- Dunlap, W. P., J. M. Cortina, J. B. Vaslow, and M. J. Burke. 1996. Meta-analysis of experiments with matched groups or repeated measures designs. *Psychological Methods* 1:170-177.
- Ernst, C. H., and E. M. Ernst. 2003. *Snakes of the United States and Canada*. Smithsonian Books, Washington, D.C.
- Ford, N. B. 1995. Experimental design in studies of snake behavior. *Herpetological Monographs* 9:130-139.

- Gove, D. 1979. A comparative study of snake and lizard tongue-flicking, with an evolutionary hypothesis. *Zeitschrift für Tierpsychologie* 51:58-76.
- Gove, D., and G. M. Burghardt. 1983. Context-correlated parameters of snake and lizard tongue-flicking. *Animal Behaviour* 31:718-723.
- Greene, H. W., and J. A. Campbell. 1972. Notes on the use of caudal lures by arboreal green pit vipers. *Herpetologica* 28:32-34.
- Heatwole, H., and E. Davison. 1976. A review of caudal luring in snakes with notes on its occurrence in the Saharan sand viper, *Cerastes vipera*. *Herpetologica* 32:332-336.
- Jackson, J. F., and D. L. Martin. 1980. Caudal luring in the dusky pygmy rattlesnake, *Sistrurus miliarius barbouri*. *Copeia* 1980:926-927.
- Keiser, E. D., Jr. 1975. Observations on tongue extension of vine snakes (Genus *Oxybelis*) with suggested behavioral hypotheses. *Herpetologica* 31:131-133.
- Krause, M. A., and G. M. Burghardt. 2001. Neonatal plasticity and adult foraging behavior in garter snakes (*Thamnophis sirtalis*) from two nearby, but ecologically dissimilar, habitats. *Herpetological Monographs* 15:100-123.
- Lillywhite, H. B., and R. W. Henderson. 1993. Behavioral and functional ecology of arboreal snakes. In R. A. Seigel and J. T. Collins (eds.), *Snakes: Ecology and Behavior*, pp. 1-48. McGraw-Hill, New York.
- Miller, D. E., and H. R. Mushinsky. 1990. Foraging ecology and prey size in the mangrove water snake, *Nerodia fasciata compressicauda*. *Copeia* 1990:1099-1106.
- Morgans, L. F., and G. A. Heidt. 1978. Comparative tongue histology and scanning electron microscopy of the diamondback water snake (*Natrix rhombifera*) and

- black rat snake (*Elaphe obsoleta*) (Reptilia, Serpentes, Colubridae). *Journal of Herpetology* 12:275-280.
- Mullin, S. J., and H. R. Mushinsky. 1995. Foraging ecology of the mangrove salt marsh snake, *Nerodia clarkii compressicauda*: effects of vegetational density. *Amphibia-Reptilia* 16:167-175.
- Murray, B. A., S. D. Bradshaw, and D. H. Edward. 1991. Feeding behavior and the occurrence of caudal luring in Burton's pygopodid *Lialis burtonis* (Sauria: Pygopodidae). *Copeia* 1991:509-516.
- Neill, W. T., Jr. 1960. The caudal lure of various juvenile snakes. *Quarterly Journal of the Florida Academy of Sciences* 23:173-200.
- , 1965. Notes on aquatic snakes, *Natrix* and *Tretanorhinus*, in Cuba. *Herpetologica* 21:62-67.
- Pasteur, G. 1982. A classificatory review of mimicry systems. *Annual Review of Ecology and Systematics* 13:169-199.
- Pough, F. H. 1988. Mimicry and related phenomena. In C. Gans and R. B. Huey (eds.), *Biology of the Reptilia*, Vol. 16, pp. 153-234. Alan R. Liss, New York.
- Schuett, G. W., D. L. Clark, and F. Kraus. 1984. Feeding mimicry in the rattlesnake *Sistrurus catenatus*, with comments on the evolution of the rattle. *Animal Behaviour* 32:625-626.
- Spindel, E. L., J. L. Dobie, and D. F. Buxton. 1987. Functional mechanisms and histologic composition of the lingual appendage in the alligator snapping turtle, *Macrolemys temmincki* (Troost) (Testudines: Chelydridae). *Journal of Morphology* 194:287-301.

- Strimple, P. D. 1992. Caudal-luring: a discussion on definition and application of the term. *In* P. D. Strimple and J. L. Strimple (eds.), *Contributions in Herpetology*, pp. 49-54. Greater Cincinnati Herpetological Society, Cincinnati.
- Ulinski, P. S. 1972. Tongue movements in the common boa (*Constrictor constrictor*). *Animal Behaviour* 20:373-382.
- Vane-Wright, R. I. 1976. Unified Classification of Mimetic Resemblances. *Biological Journal of the Linnean Society* 8:25-56.
- Welsh, H. H., Jr, and A. J. Lind. 2000. Evidence of lingual-luring by an aquatic snake. *Journal of Herpetology* 34:67-74.
- Wickler, W. 1968. *Mimicry in plants and animals*. London : Weidenfeld & Nicolson
- Young, B. A. 1997. On the absence of taste buds in monitor lizards (*Varanus*) and snakes. *Journal of Herpetology* 31:130-137.

Appendix 1

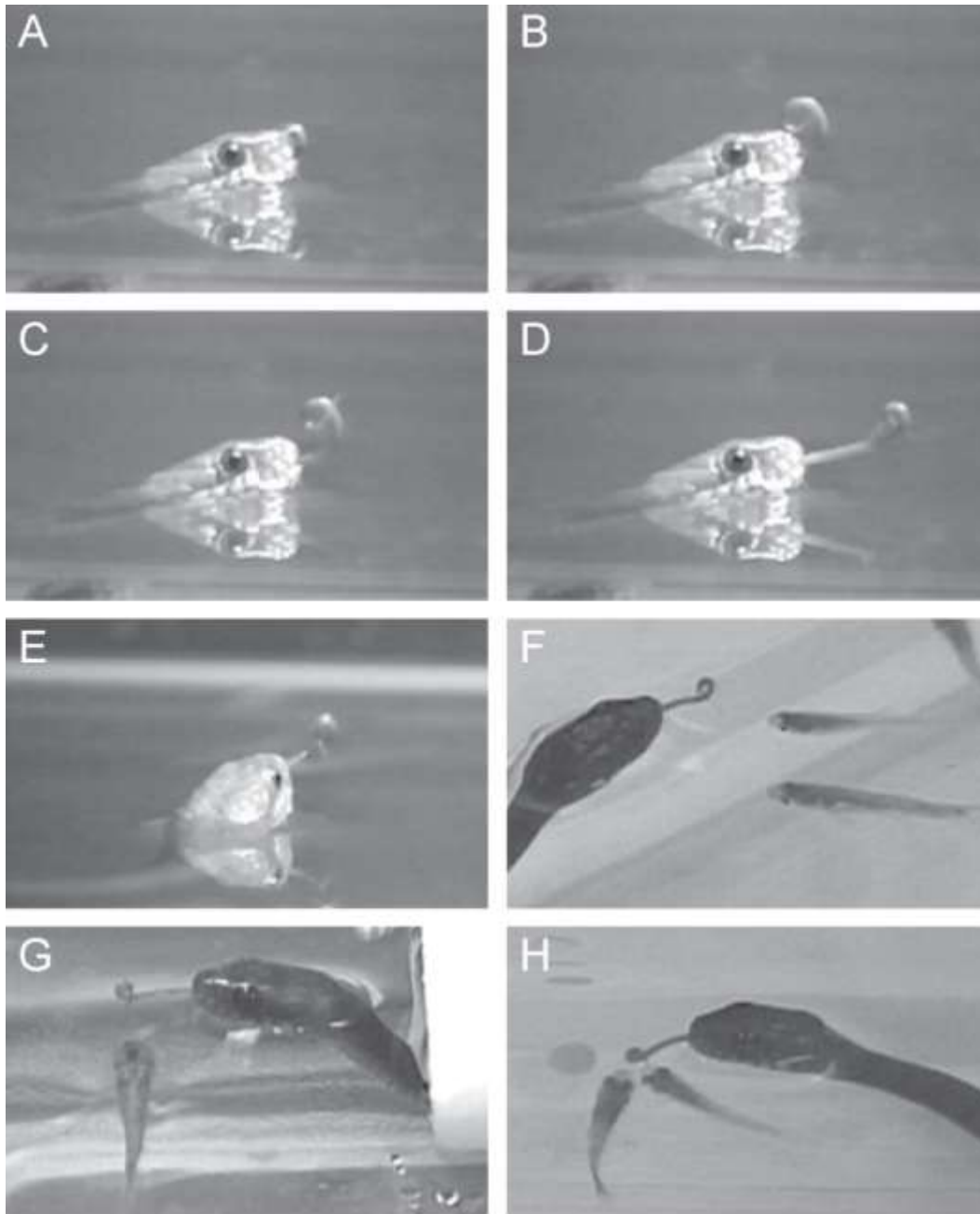

Figure 1. 1. (A–D) Sequence of noteworthy points in the protraction phase of a luring tongue flick by *Nerodia clarkii compressicauda*. (E) Lateral deflection of the tongue during the luring phase. (F–H) Attraction of fish toward the tongue during the luring phase. Images are unaltered except for cropping and global changes to size, brightness, and contrast. The retraction phase (not shown) follows the luring phase and involves uncurling of the terminal loop as the tongue is withdrawn into the mouth.

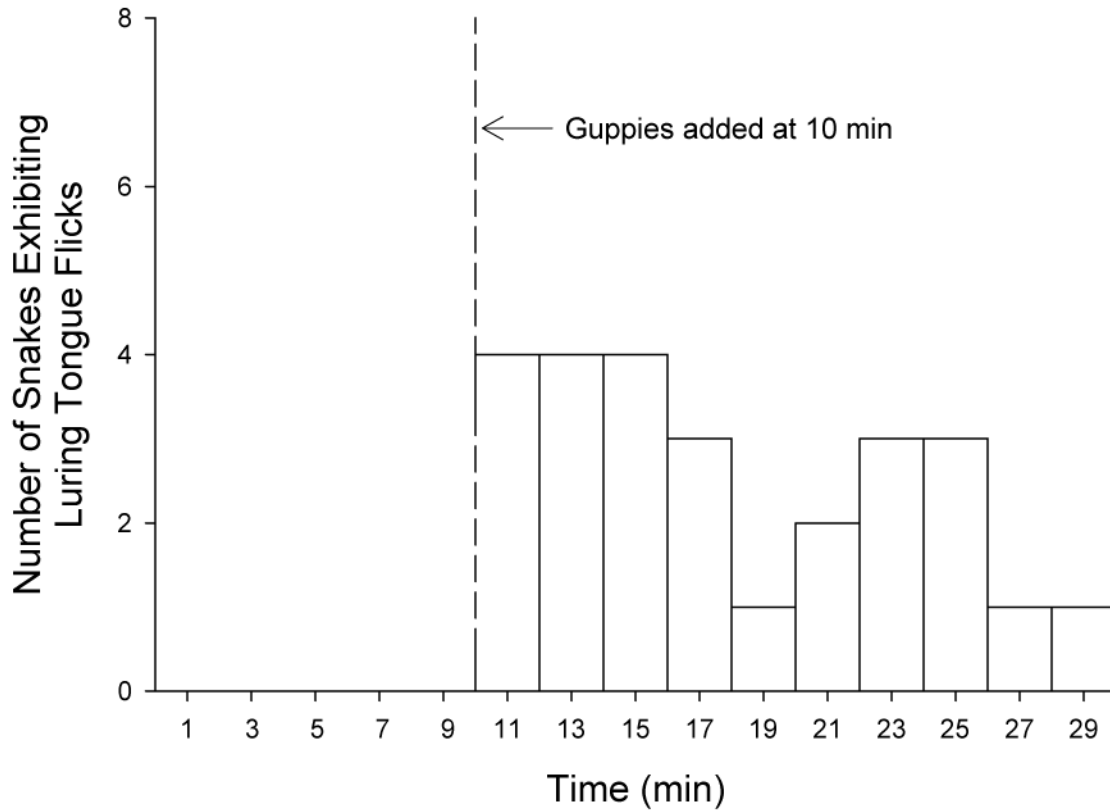

Figure 1. 2. Frequency distribution of latencies of luring tongue flicks exhibited by eight juvenile *Nerodia clarkii compressicauda* during 30-minute individual observation periods. Each snake was alone in a feeding chamber during the first 10 minutes of the observation period. Four guppies (*Poecilia reticulata*) were added to the feeding chamber 10 minutes after observations began.

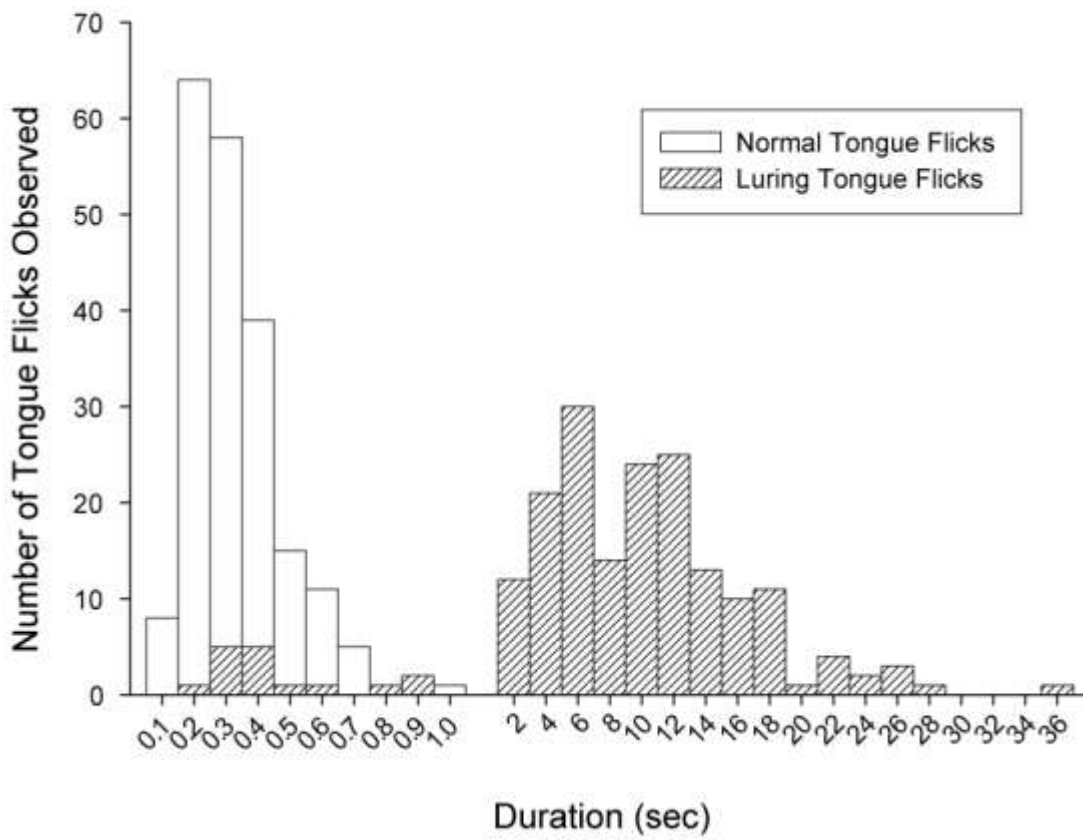

Figure 1. 3. Frequency distribution of durations of normal tongue flicks ($N = 188$) and luring tongue flicks ($N = 188$) exhibited by 19 neonate and juvenile *Nerodia clarkii compressicauda*. Different bin widths are used below (0.1 seconds) and above (2 seconds) the gap on the x-axis to prevent variation in normal tongue-flick duration from being hidden within a single bar.

**PART 2. STIMULUS CONTROL OF LINGUAL PREDATORY LURING AND
RELATED FORAGING TACTICS OF MANGROVE SALTMARSH SNAKES
(*NERODIA CLARKII COMPRESSICAUDA*)**

This part is a version of a manuscript by the same name submitted for publication in the journal *Journal of Comparative Psychology* in 2009 by Kerry A. Hansknecht and Gordon

M. Burghardt.

My use of ‘we’ in this part refers to my coauthor and myself. My contributions to this paper include (1) selection of the topic, (2) design and implementation of the experiments, (3) collection and analysis of data, and (4) nearly all of the writing.

Abstract

Knowledge of the various cues that elicit natural behavior is important to our understanding of why and when animals behave as they do. In order to gain insight into the behavior and ecology of *Nerodia clarkii compressicauda*, a piscivorous snake that uses a unique form of predatory luring as a foraging tactic, we observed 22 juvenile subjects in the presence of visual and chemical prey stimuli in a repeated-measures design. The use of video playback as a visual stimulus in this experiment permitted complete isolation from tactile and chemical cues. Snakes were more sedentary and employed lingual luring more when both cue types were present than when none or only one of the cues was available. Subjects also attacked more often in the presence of both stimuli. Predatory attacks by prey-naïve subjects directed to video cues when only visual prey stimuli were available demonstrated that snakes can identify prey visually without prior experience.

Introduction

The behavior of animals depends largely on the many sensory cues available to them, and these environmental stimuli can be detected via several sensory modes, such as chemical, visual, tactile, and acoustic (Dusenbery, 1992). Moreover, variation in the number or assortment of available stimuli, be they of the same or different sensory modes, has been linked to behavioral plasticity in animals from several groups, including arthropods (Marchand & McNeil, 2004; Uetz & Roberts, 2002; Raguso & Willis, 2005), fish (New, 2002; Ferrari et al., 2008; Brown & Magnavacca, 2003), amphibians (Narins, Grabul, Soma, Gaucher, & Hödl, 2005), reptiles (Burghardt & Denny, 1983; Shivik,

1998), birds (Montgomerie & Weatherhead, 1997), and mammals (Piep, Radespiel, Zimmermann, Schmidt, & Siemers, 2008; Partan, Larco, & Owens, 2009). Using such knowledge of the various stimuli that elicit a certain behavior, we can gain insight into why that behavior might be exhibited in some situations but not others. For example, Drummond (1985) found that natricine snakes that specialize in aquatic foraging spent more time diving in the presence of fish chemical cues than in their absence. This indicates that diving when foraging might be restricted to situations in which there is reliable information that fish are currently present in a particular location, and diving might not be used as a general search tactic. Because environmental conditions predicate which types (modes) of prey stimuli may be perceivable, the cues used by a predator will depend on where and when it forages. Prowling underground or in the dark is not likely to provide much in the way of visual prey cues, and capture of aquatic prey from terrestrial or arboreal positions probably will not be facilitated by tactile cues (Drummond, 1979). As such, we can learn much about a predator's foraging ecology simply by determining the relative importance of various prey cues; a predator found to require visual cues for prey identification or capture is probably not a fossorial forager.

Information regarding the stimuli important to a foraging predator can provide clues about not only where and when it forages but also the foraging strategy used. The activity level of a predator is often influenced by the activity level of its prey, and this relationship can also determine which stimulus modes will be of use. Predators that target highly active prey are usually themselves fairly sedentary foragers, while those that target sedentary prey typically spend much of their hunting time in motion (Huey & Pianka, 1981; Rosenheim & Corbett, 2003; Scharf, Nulman, Ovadia, & Bouskila, 2006; Turnbull,

1973; Woodward & Hildrew, 2002). Visual stimuli appear to be more important to sedentary predators seeking active prey, while chemical stimuli seem more important to active predators seeking sedentary prey (Cooper, 1994, 1995). Thus, knowledge of which stimuli are important to a predator can provide clues about where that predator's strategy lies on the continuum between active and sedentary. Among predators that exhibit foraging-mode switching (Helfman, 1990), the type of prey stimuli available may play a major role in determining when or where such switching occurs.

For predators about which little is known, laboratory studies of how different types of prey stimuli influence the predators' foraging behaviors should provide clues regarding their habits in the field, and they can also help us determine where such predators fall in regard to various categorizing schemes, such as the foraging-mode continuum. The mangrove saltmarsh snake (*Nerodia clarkii compressicauda*), a piscivore inhabiting the red mangrove (*Rhizophora mangle*) forests of southeastern North America (Ernst & Ernst, 2003), is one such predator. In the present study, we sought to determine the effect of visual and chemical prey stimuli on a number of behaviors associated with foraging. While several workers have examined the effects of these types of stimuli on the foraging behavior of snakes (Burghardt, 1970; Burghardt & Denny, 1983; Burghardt & Hess, 1968; Chiszar, Kandler, & Smith, 1988; Reiserer, 2002; Shivik, 1998), including other *Nerodia* (Bowen, 2001; Drummond, 1985), we were particularly interested in stimulus control of the predatory luring exhibited by newborn *N. c. compressicauda* (Hansknecht, 2008) and in assessing how different prey stimuli influenced their foraging strategy in the absence of prior experience with prey stimuli and associated experiential and cognitive

effects. We did this by observing naïve subjects in the presence of visual and chemical prey stimuli alone and in combination in a repeated-measures design.

Method

Subjects

Subjects were 22 mangrove saltmarsh snakes (*Nerodia clarkii compressicauda*) taken from four litters of Florida Keys origin. Eight snakes, four from each of two litters (A and B), were born to wild-caught females, and 14 snakes, five from one litter (C) and nine from another (D), were born to long-term captives mated in the laboratory. The proportions of males tested from litters A – D were 0.75, 0.25, 0.40, and 0.22, respectively. Neonate snakes were moved to individual enclosures the morning after their birth and provided shelter and water ad libitum. All subjects were kept in a room devoid of prey cues until the time of testing at two to three weeks of age (snakes often do not show interest in prey or eating until they are at least two weeks old).

Apparatus

The test arena (Figure 2.1) was a 21-l glass aquarium subdivided to form a square chamber 20 x 20 x 25 cm. The floor of the chamber was textured (Hansknecht & McDonald, 2009) to improve the locomotory ability of the subjects, and the arena contained distilled water to a depth of 2 cm during trials. A longitudinally bisected 11.5-cm length of gray pvc tubing (1.9-cm inside diameter) affixed to a flat base with its inner surface facing upward provided an anchorage/ambush site for the subjects. Vinyl tubing affixed vertically to the corner of the arena opposite the ambush site allowed delivery of chemical cues into the water via a smaller tube attached to a syringe and inserted into the

larger tube prior to trials. The walls and floor were painted opaque medium gray except for a 13.5 x 3.5-cm window near the floor on one side. This allowed visual cues to be presented both above and below the water line from outside the arena. Four identical test arenas were constructed, two for trials that involved fish odors and two for trials that did not. All trials were recorded using a Canon Optura 20 digital video camera connected directly to a computer and mounted 0.5 m above the center of the arena floor.

Stimuli

Four prey-stimulus treatments were used: control (Co), visual cues only (Vi), chemical cues only (Ch), both visual and chemical cues together (Bo). A 38-s video recording of six guppies provided the visual stimulus, enabling complete isolation from chemical and tactile cues. The video was recorded against a black background, providing high contrast between the well-lit guppies and the background. This video clip was replayed in a repeating loop and displayed on a computer monitor adjacent to the transparent window of the test arena. The beginning and end of the video clip displayed only the background, and the fish naturally swam into and out of view at these times as well as others during the clip; at no time did fish instantaneously appear or disappear in the viewing area. The size and location of the video imagery was adjusted such that the guppies were approximately 1.5 – 2 cm long and, as they swam about, could be seen by subjects both above and below the level of the water's surface. The visual control was produced by pausing the video clip at its beginning, before any guppies appeared on the screen. The prey chemical stimulus was produced by allowing 100 minnows (*Pimephales promelas*) to swim in 2 l of deionized water for 4 hr. Samples (12 ml) of this water were then frozen in vials that were warmed individually to room temperature as needed. Deionized water

alone provided the chemical control. Each snake was subjected to all four stimulus treatments in one of four test orders: Co-Vi-Ch-Bo, Vi-Bo-Co-Ch, Ch-Co-Bo-Vi, and Bo-Ch-Vi-Co. Subjects were assigned test orders randomly within litters, and in all litters at least one snake received each of the four test orders.

Procedure

Subjects were tested singly for 15 min in the presence of each of the four test conditions over a period of approximately 2 hr. Two rooms in separate laboratory suites were used for testing: one for trials involving chemical cues and one for trials involving none. No fish were kept in or near either room, and the trials involving no chemical cues (Co and Vi) were conducted in a room where no fish had been kept for at least 5 years.

Subjects were moved to the testing room in their home cages approximately 10 min before the start of trials. Prior to introduction of the snake into the test arena, the video clip was paused at its beginning, 0.8 l of distilled water was added to the test arena, the syringe used to introduce the chemical stimulus or chemical control was filled with 10 ml of the appropriate water, and the syringe tube was inserted into the arena-mounted delivery tube. The syringe remained outside and well below the top of the arena to prevent subjects from seeing the experimenter while the water was being delivered, and controls for starting video playback were also positioned to prevent subjects from seeing the experimenter during operation.

Subjects were then carefully transferred from their home cage to the center of the test arena and allowed to acclimate for 5 min. At the end of the acclimation period, the chemical stimulus (Ch and Bo trials) or distilled water (Co and Vi trials) was introduced into the test arena at a rate of 0.5 ml/s, and fish-video playback was initiated (Vi and Bo

trials only). Test arenas were washed thoroughly during the 30 min between each trial. Air and water temperatures were maintained at $24 \pm 1^\circ\text{C}$.

Data Collection and Analysis

Video-recordings of trials were reviewed to obtain measures of the following variables: number of luring tongue flicks (LTF), number of attacks, percent time moving (PTM), number of movements per minute (MPM), and percent time spent in the anterior 1/3rd of the arena (near the window; PTF). MPM and PTM are commonly used metrics of foraging activity (Cooper, 2005). Because very brief movements seem more likely to be slight adjustments in orientation rather than locomotory events, a criterion of 2 s was used to identify changes in state between moving and still subjects; movements and pauses shorter than 2 seconds were ignored.

For LTF and attack count data we conducted Quade tests to examine the hypotheses that the means were equal across the four stimulus treatments (Conover, 1999). Data for the remaining variables met the sphericity assumption, and we analyzed these using repeated-measures ANOVA in SPSS. For post hoc analyses following repeated-measures ANOVA, we used the step-down Bonferroni method of Holm (Aickin & Gensler, 1996) to adjust the p -values obtained from paired t -tests (Quinn & Keough, 2002). We used the method of Conover (1999) for multiple comparisons following the Quade test. For LTFs and attacks, we used individual means across treatments in a Kruskal-Wallis test to detect litter and sex effects. For all statistical hypothesis tests, $\alpha = 0.05$. Estimates of effect size were calculated by hand and included Cohen's d , a modified form of Cohen's d (identified herein as d_{ct}) proposed by Dunlap, Cortina, Vaslow, and Burke (1996) for

comparisons involving correlated data, and η^2 (Levine & Hullett, 2002). Means are reported with 95% confidence intervals (CI).

Results

Number of Luring Tongue Flicks (LTF)

Subjects exhibited LTFs an average of 1.1 ± 0.67 times during trials, and the response differed significantly between treatments (Quade test, $T = 7.43$, $df = 3$, 63 , $p < 0.001$; Figure 2.2). LTFs occurred in all three experimental conditions but not in the control treatment. Multiple comparisons following the method of Conover (1999) indicated that the number of LTFs exhibited differed significantly between trials involving both chemical and visual cues together (Bo) and trials involving chemical cues alone (Ch), visual cues alone (Vi), and no prey cues at all (Co). No other pairwise comparisons were statistically significant. There was no significant effect of litter (Kruskal-Wallis test, $\chi^2_{(3, N=22)} = 4.02$, $p = 0.260$) or sex (Kruskal-Wallis test, $\chi^2_{(1, N=22)} = 0.203$, $p = 0.652$). Effect size estimates for pairwise comparisons are shown in Table 2.1.

Number of Attacks

Subjects exhibited an average of 0.27 ± 0.18 attacks during trials, and the response differed significantly between the four treatments (Quade test, $T = 6.69$, $df = 3$, 63 , $p < 0.001$; Figure 2.3). No attacks occurred in the control condition, but they did occur in all other conditions. The number of attacks exhibited differed significantly between trials involving both chemical and visual cues together (Bo) and trials involving chemical cues alone (Ch), visual cues alone (Vi), and no prey cues at all (Co). No other pairwise

comparisons were statistically significant. There was no effect of sex (Kruskal-Wallis test, $\chi^2_{(1, N=22)} = 0.309, p = 0.578$), but a significant effect of litter did exist (Kruskal-Wallis test, $\chi^2_{(3, N=22)} = 10.23, p = 0.017$). Effect size estimates for pairwise comparisons are shown in Table 2.1.

Percent Time Moving (PTM)

Across all treatments, subjects spent an average of 55.1 ± 4.8 % of the time moving during the 15-min trials, and PTM differed significantly between stimulus treatments (repeated measures ANOVA, $F_{3,42} = 10.12, p < 0.001; \eta^2 = 0.32$; Figure 2.4). There were no significant interactions involving sex ($F_{3,42} = 0.499, p = 0.685; \eta^2 = 0.016$) or litter ($F_{9,42} = 1.69, p = 0.123; \eta^2 = 0.16$). PTM differed significantly between trials involving both chemical and visual cues together (Bo) and trials involving only visual cues (Vi; paired $t_{(21)} = 4.59, p'_{stb} < 0.001; d_{ct} = 1.36$), only chemical cues (Ch; paired $t_{(21)} = 2.83, p'_{stb} = 0.030; d_{ct} = 0.91$), and no prey cues at all (Co; paired $t_{(21)} = 7.66, p'_{stb} < 0.001; d_{ct} = 2.41$). PTM also differed significantly between trials involving only chemical cues (Ch) and trials involving no prey cues at all (Co; paired $t_{(21)} = 3.37, p'_{stb} = 0.012; d_{ct} = 1.02$). There was no difference in PTM between control trials (Co) and visual-only (Vi) trials (paired $t_{(21)} = 2.24, p'_{stb} = 0.072; d_{ct} = 0.76$) or chemical-only (Ch) and visual-only (Vi) trials (paired $t_{(21)} = 0.78, p = 0.444; d_{ct} = 0.31$). There were significant between-subjects effects of both litter ($F_{3,14} = 5.35, p = 0.011; \eta^2 = 0.40$) and sex ($F_{1,14} = 5.11, p = 0.040; \eta^2 = 0.13$), but no significant interaction was found ($F_{3,14} = 1.64, p = 0.225; \eta^2 = 0.12$).

Movements Per Minute (MPM)

Subjects made an average of 0.95 ± 0.15 movements per minute during trials across all treatments. MPM did not differ significantly between stimulus treatments (repeated

measures ANOVA, $F_{3,42} = 2.06$, $p = 0.12$; $\eta^2 = 0.09$; Figure 2.5), and there were no significant interactions involving sex ($F_{3,42} = 0.837$, $p = 0.481$; $\eta^2 = 0.04$) or litter ($F_{9,42} = 1.08$, $p = 0.399$; $\eta^2 = 0.15$). There were no significant between-subjects effects of either litter ($F_{3,14} = 2.18$, $p = 0.136$; $\eta^2 = 0.31$) or sex ($F_{1,14} = 0.074$, $p = 0.790$; $\eta^2 = 0.003$), and no significant interaction was found ($F_{3,14} = 1.64$, $p = 0.225$; $\eta^2 = 0.03$).

Percent Time near Front (PTF)

Across all treatments, subjects spent an average of 66.9 ± 6.5 % of the time in the anterior 1/3rd of the arena. PTF differed significantly among stimulus treatments (repeated measures ANOVA, $F_{3,42} = 4.29$, $p = 0.010$; $\eta^2 = 0.16$), and there was a significant interaction between treatment and sex ($F_{3,42} = 4.76$, $p = 0.006$; $\eta^2 = 0.17$; Figure 6) but not litter ($F_{9,42} = 0.721$, $p = 0.687$; $\eta^2 = 0.08$). There was a significant between-subjects effect of litter ($F_{3,14} = 7.49$, $p = 0.003$; $\eta^2 = 0.49$) but not sex ($F_{1,14} = 1.64$, $p = 0.221$; $\eta^2 = 0.04$), and no significant interaction was found ($F_{3,14} = 2.64$, $p = 0.361$; $\eta^2 = 0.17$).

Discussion

A strong synergistic effect was observed with respect to the visual and chemical cues presented to mangrove saltmarsh snakes and the foraging behaviors exhibited by them. A single prey cue resulted in limited exhibition of lingual luring, while a combination of two types of prey cues dramatically increased exhibition of luring behavior. This was observed to an even greater degree with respect to predatory attacks, of which few were made in the presence of just a single prey cue. A notable difference between luring tongue flicks and attacks was the relative importance of the different types of cues. Effect

size estimates indicated that LTFs were more heavily mediated by chemical cues, whereas attacks were somewhat more heavily mediated by visual cues. Snakes also tended to spend disproportionately more time in the vicinity of the prey cue delivery areas than in the rest of the test arena. This not only agrees with other response variables in regard to the synergistic effect of multimodal stimuli but also illustrates the effectiveness of using video imagery in stimulus experiments with snakes.

These findings echo those of others in that prey-derived visual and chemical stimuli were each by themselves sufficient to elicit a specific behavior, in this case lingual luring, and that together the two cues types elicited a greater response than would be expected from mere summation. Sensory complementation, specifically multimodal enhancement such as this, has been well documented (Drummond, 1985; Partan et al., 2009; Raguso & Willis, 2005; Shivik & Clark, 1997; Smith & Belk, 2001; Terrick, Mumme, & Burghardt, 1995). Partan et al. (2009) suggest that such multimodal redundancy is likely to exist where a particular behavior is especially important to survival, and foraging behaviors certainly meet that criterion. The use of multiple sensory cues for prey identification allows for greater situational plasticity in predatory behavior, permitting foraging at different locations, times, light intensities, etc. At the same time, a predator is more likely to be successful in detecting prey in a given situation as fewer cues become necessary for prey detection and identification.

Although with most natricine snakes chemical cues are essential for eliciting predatory attacks, especially in ingestively naïve individuals (Burghardt, 1969, 1993), in this study we found that attacks were directed at visual stimuli in the absence of prey-derived chemical stimuli, including attacks made during a subject's first trial, prior to any

experience at all with prey chemical cues. Drummond (1985) made similar observations with two other piscivorous natricines. However, the use of video playback in the present experiment eliminated not only chemical cues but tactile/vibratory cues as well. Thus, we have further evidence that these snakes can innately identify and will attack prey based on visual cues alone. While this does not undermine the importance of prey chemical cues to the identification of prey by aquatic natricine snakes (Burghardt, 1968, 1969; Waters & Burghardt, 2005), it does suggest considerable flexibility without the need for prior experience.

Subjects were more sedentary in the presence of both chemical and visual cues together than in the presence of visual cues only or no prey cues at all, and they spent less time moving in the presence of chemical cues alone than no prey cues at all. This marked decrease in activity associated with an increase in prey-specific stimuli might suggest that mangrove saltmarsh snakes are reasonably sedentary predators. However, the PTM values observed here, even in the presence of multimodal stimuli (mean $PTM_{Bo} = 32\%$), exceed the value (15%) recognized as the upper limit for lizards considered to be sit-and-wait predators (Butler, 2005; Cooper, 2005). In addition, the subjects in this study averaged approximately one move per minute, which is similar to intermediate- to active-foraging lizards (Cooper, 2005). With very little comparable quantitative data for snakes, it is difficult to determine where *N. c. compressicauda* may lie on the foraging-mode continuum, but it appears to hold an intermediate to moderately active position in this respect. This finding is preliminary, however, given the artificial laboratory conditions involved here. Access to live fish and the ability to capture them could conceivably reduce PTM, as snakes might remain at a particular location where they find success. It is

convenient that PTM data are available for two species of *Nerodia*, mangrove saltmarsh snakes and northern watersnakes (*N. sipedon*). Both of these studies (Balent & Andreadis, 1998; Mullin & Mushinsky, 1995) were in more natural settings, and they indicate that these snakes are intermediate foragers (PTM \approx 15%) considerably more sedentary than we have found here. The general trend for more active predators to primarily use chemical cues and sedentary predators to primarily use visual cues (Cooper, 1994, 1995) is complemented by a trend for predators that use an intermediate or mixed strategy (Balent & Andreadis, 1998) to put stock in both visual and chemical cues (Drummond, 1985), and *N. c. compressicauda* certainly does that.

The data shown in Figure 4 agree with the suggestion of Shivik, Bourassa, & Donnigan (2000) that a shift in foraging mode may occur as more stimulus modes become involved in prey detection. However, an important point typically ignored in studies of predator foraging modes, and especially mode switching, is that activity levels might also change at the interface between the search and pursuit phases of the predation sequence (Curio, 1976; Helfman, 1990). Thus, a predator might be active during the search phase but switch to a sedentary foraging mode for the pursuit phase, or perhaps vice-versa, and this would likely be influenced by the prey stimuli attended to or perceived by the predator. It is reasonable to expect this transition to occur somewhere, which would depend on the predator and foraging modes in question, along a continuum of prey-related stimuli that ranges from the complete absence of prey cues to the actual presence of prey. The former state was represented here by a control treatment, while the latter was approximated by the treatment involving paired stimuli. Given that the subjects in this study were more active in the control treatment and more sedentary in the

treatment involving multiple prey stimuli, *Nerodia clarkii compressicauda* may be exhibiting a foraging-mode switch from active to sedentary associated with a transition from the search phase to the pursuit phase as the snakes encounter evidence of the presence of prey. Given the data presented here, studies concerning the roles of successful and unsuccessful predation on use of the various cues and the foraging tactics deployed would aid in further understanding the flexibility of foraging in snakes.

Literature Cited

- Aickin, M., and H. Gensler. 1996. Adjusting for multiple testing when reporting research results: the Bonferroni vs Holm methods. *American Journal of Public Health* 86:726-728.
- Algina, J., H. J. Keselman, and R. D. Penfield. 2005. Effect sizes and their intervals: the two-level repeated measures case. *Educational and Psychological Measurement* 65:241–258.
- Balent, K. L., and P. T. Andreadis. 1998. The mixed foraging strategy of juvenile northern water snakes. *Journal of Herpetology* 32:575-579.
- Bowen, K. D. 2001. The role of visual and tactile cues in the foraging behavior of the Florida banded watersnake, *Nerodia fasciata pictiventris*. *Bulletin of the Chicago Herpetological Society* 36:218-221.
- Brown, G. E., and G. Magnavacca. 2003. Predator inspection behaviour in a characin fish: an interaction between chemical and visual information? *Ethology* 109:739–750.
- Burghardt, G. M. 1968. Chemical preference studies on newborn snakes of three sympatric species of *Natrix*. *Copeia* 1968:732-737.
- , 1969. Comparative prey-attack studies in newborn snakes of the genus *Thamnophis*. *Behaviour* 33:77–114.
- , 1970. Chemical perception in reptiles. In J. W. Johnston, D. C. Moulton, Jr., and A. Turk (eds.), *Communication by chemical signals*, pp. 241–308. Appleton-Century-Crofts, New York.

- , 1993. The comparative imperative: genetics and ontogeny of chemoreceptive prey responses in natricine snakes. *Brain Behavior and Evolution* 41:138-146.
- Burghardt, G. M., and D. Denny. 1983. Effects of prey movement and prey odor on feeding in garter snakes. *Zeitschrift für Tierpsychologie* 62:329-347.
- Burghardt, G. M., and E. H. Hess. 1968. Factors influencing chemical release of prey attack in newborn snakes. *Journal of Comparative and Physiological Psychology* 66:289–295.
- Butler, M. A. 2005. Foraging mode of the chameleon, *Bradypodion pumilum*: a challenge to the sit-and-wait versus active forager paradigm? *Biological Journal of the Linnean Society* 84:797-808.
- Chiszar, D., K. Kandler, and H. M. Smith. 1988. Stimulus control of predatory attack in the brown tree snake (*Boiga irregularis*). 1. Effects of visual cues arising from prey. *Snake* 20:151-155.
- Conover, W. J. 1999. *Practical nonparametric statistics*. Wiley, New York.
- Cooper, W. E. 1994. Chemical discrimination by tongue flicking in lizards: a review with hypotheses on its origin and its ecological and phylogenetic relationships. *Journal of Chemical Ecology* 20:439–487.
- , 1995. Foraging mode, prey chemical discrimination, and phylogeny in lizards. *Animal Behaviour* 50:973–985.
- , 2005. The foraging mode controversy: both continuous variation and clustering of foraging movements occur. *Journal of Zoology* 267:179-190.
- Curio, E. 1976. *The ethology of predation*. Springer-Verlag, Berlin.

- Drummond, H. 1985. The role of vision in the predatory behavior of natricine snakes. *Animal Behaviour* 33:206-215.
- Drummond, H. M. 1979. Stimulus control of amphibious predation in the northern water snake (*Nerodia s.sipedon*). *Zeitschrift für Tierpsychologie* 50:18-44.
- Dunlap, W. P., J. M. Cortina, J. B. Vaslow, and M. J. Burke. 1996. Meta-analysis of experiments with matched groups or repeated measures designs. *Psychological Methods* 1:170-177.
- Dusenbery, D. B. 1992. *Sensory ecology: how organisms acquire and respond to information*. Freeman, New York.
- Ernst, C. H., and E. M. Ernst. 2003. *Snakes of the United States and Canada*. Smithsonian Books, Washington, D.C.
- Ferrari, M. C. O., M. A. Vavrek, C. K. Elvidge, B. Fridman, D. P. Chivers, and G. E. Brown. 2008. Sensory complementation and the acquisition of predator recognition by salmonid fishes. *Behavioral Ecology and Sociobiology* 63:113–121.
- Hansknecht, K. A. 2008. Lingual luring by mangrove saltmarsh snakes (*Nerodia clarkii compressicauda*). *Journal of Herpetology* 42:9-15.
- Helfman, G. S. 1990. Mode selection and mode switching in foraging animals. *In* P. J. B. Slater, J. S. Rosenblatt, and C. Beer (eds.), *Advances in the Study of Behavior*, Vol. 19, pp. 249-298. Academic Press, San Diego.
- Huey, R. B., and E. R. Pianka. 1981. Ecological consequences of foraging mode. *Ecology* 62:991-999.

- Levine, T. R., and C. R. Hullett. 2002. Eta squared, partial eta squared, and misreporting of effect size in communication research. *Human Communication Research* 28:612-625.
- Marchand, D., and J. N. McNeil. 2004. The importance of behavioral plasticity for maximizing foraging efficiency in frugivorous lepidopteran larvae. *Journal of Insect Behavior* 17:673-684.
- Montgomerie, R., and P. J. Weatherhead. 1997. How robins find worms. *Animal Behaviour* 54:143-151.
- Mullin, S. J., and H. R. Mushinsky. 1995. Foraging ecology of the mangrove salt marsh snake, *Nerodia clarkii compressicauda*: effects of vegetational density. *Amphibia-Reptilia* 16:167-175.
- Narins, P. M., D. S. Grabul, K. K. Soma, P. Gaucher, and W. Hödl. 2005. Cross-modal integration in a dart-poison frog. *Proceedings of the National Academy of Sciences of the United States of America* 102:2425–2429.
- New, J. G. 2002. Multimodal integration in the feeding behaviors of predatory teleost fishes. *Brain Behavior and Evolution* 59:177-189.
- Partan, S. R., C. P. Larco, and M. J. Owens. 2009. Wild tree squirrels respond with multisensory enhancement to conspecific robot alarm behaviour. *Animal Behaviour* 77:1127–1135.
- Piep, M., U. Radespiel, E. Zimmermann, S. Schmidt, and B. M. Siemers. 2008. The sensory basis of prey detection in captive-born grey mouse lemurs, *Microcebus murinus*. *Animal Behaviour* 75:871-878.

- Quinn, G. P., and M. J. Keough. 2002. Experimental design and data analysis for biologists Cambridge University Press, Cambridge.
- Raguso, R. A., and M. A. Willis. 2005. Synergy between visual and olfactory cues in nectar feeding by wild hawkmoths, *Manduca sexta*. *Animal Behaviour* 69:407-418.
- Reiserer, R. S. 2002. Stimulus control of caudal luring and other feeding responses: a program for research on visual perception in vipers. *In* G. W. Schuett, M. Höggren, M. E. Douglas, and H. W. Greene (eds.), *Biology of the Vipers*, pp. 363-383. Eagle Mountain Publishing, Eagle Mountain, UT.
- Rosenheim, J. A., and A. Corbett. 2003. Omnivory and the indeterminacy of predator function: can a knowledge of foraging behavior help? *Ecology* 84:2538-2548.
- Scharf, I., E. Nulman, O. Ovadia, and A. Bouskila. 2006. Efficiency evaluation of two competing foraging modes under different conditions. *American Naturalist* 168:350-357.
- Shivik, J. A. 1998. Brown tree snake response to visual and olfactory cues. *Journal of Wildlife Management* 62:105-111.
- Shivik, J. A., J. Bourassa, and S. N. Donnigan. 2000. Elicitation of brown treesnake predatory behavior using polymodal stimuli. *Journal of Wildlife Management* 64:969-975.
- Shivik, J. A., and L. Clark. 1997. Carrion seeking in brown tree snakes: importance of olfactory and visual cues. *Journal of Experimental Zoology* 279:549-553.

- Smith, M. E., and M. C. Belk. 2001. Risk assessment in western mosquitofish (*Gambusia affinis*): do multiple cues have additive effects? Behavioral Ecology and Sociobiology 51:101–107.
- Terrick, T. D., R. L. Mumme, and G. M. Burghardt. 1995. Aposematic coloration enhances chemosensory recognition of noxious prey in the garter snake *Thamnophis radix*. Animal Behaviour 49:857-866.
- Turnbull, A. L. 1973. Ecology of true spiders (Araneomorphae). Annual Review of Entomology 18:305-348.
- Uetz, G. W., and J. A. Roberts. 2002. Multisensory cues and multimodal communication in spiders: Insights from video/audio playback studies. Brain Behavior and Evolution 59:222-230.
- Woodward, G., and A. G. Hildrew. 2002. Differential vulnerability of prey to an invading top predator: integrating field surveys and laboratory experiments. Ecological Entomology 27:732-744.

Appendix 2

Table 2. 1. Effect size estimates of differences in luring tongue flick (LTF) and attack responses by mangrove saltmarsh snakes (*Nerodia clarkii compressicauda*) to different prey stimulus treatments.

Stimulus treatment pair ^a	Response	
	LTF	Attack
Control – Visual	0.30	0.51
Control – Chemical	0.50	0.55
Control – Both	0.79	0.84
Visual – Chemical	0.42	0.11
Visual – Both	0.72	0.60
Chemical – Both	0.30	0.67

Note. Values are Cohen’s *d*.

^a Both refers to both chemical and visual cues presented together.



Figure 2. 1. The test arena used for stimulus-control experiments involving chemical and visual cues. The circular structure on the right was added after the present experiments were completed.

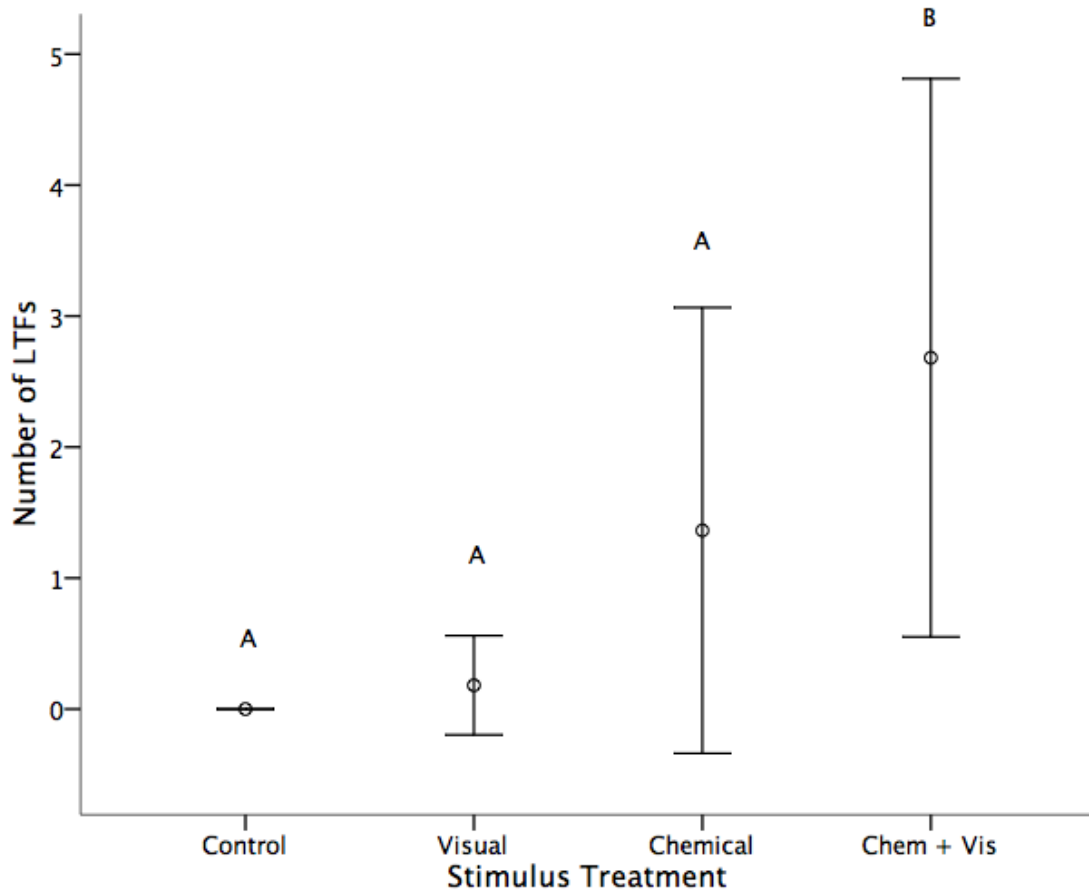

Figure 2. 2. Mean number of luring tongue flicks (\pm 95 % CI) exhibited by ingestively naïve neonate mangrove saltmarsh snakes (*Nerodia clarkii compressicauda*) in the presence of four different prey stimulus treatments. Means that do not share superscribed letters are significantly different from each other.

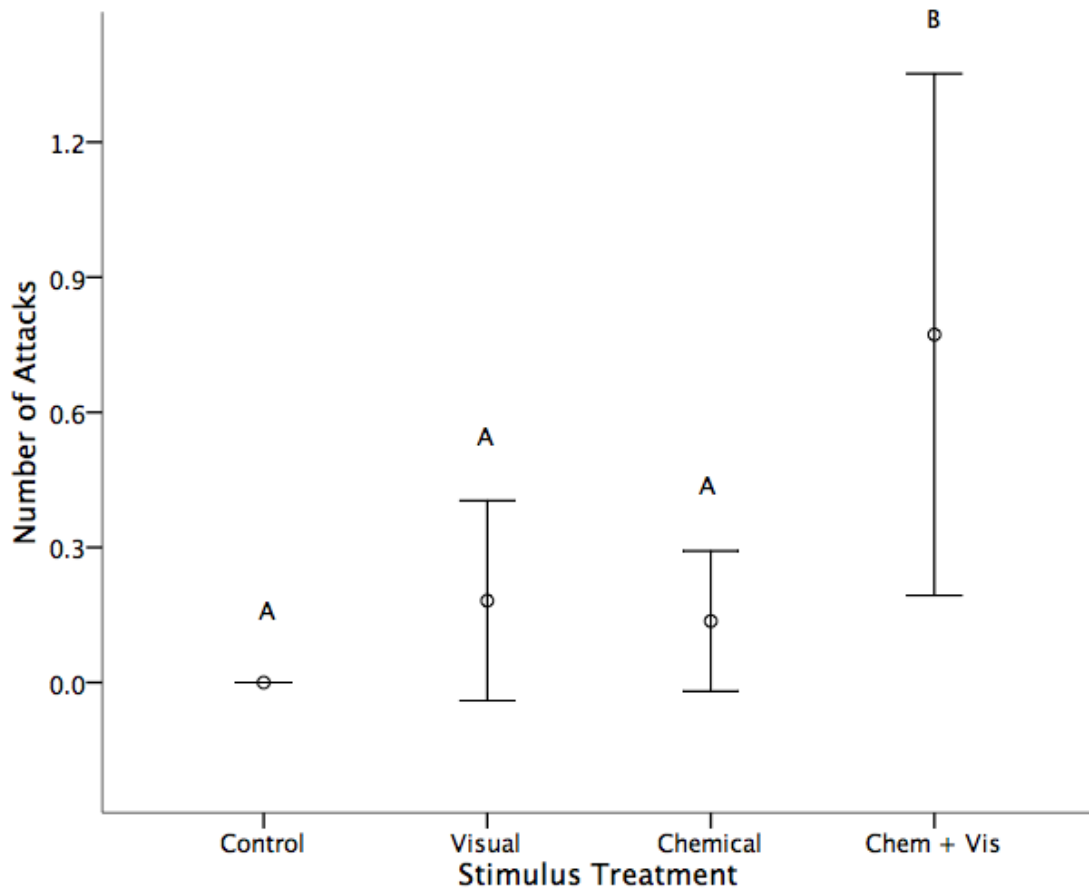

Figure 2. 3. Mean number of attacks (\pm 95 % CI) exhibited by ingestively naïve neonate mangrove saltmarsh snakes (*Nerodia clarkii compressicauda*) in the presence of four different prey stimulus treatments. Means that do not share superscribed letters are significantly different from each other.

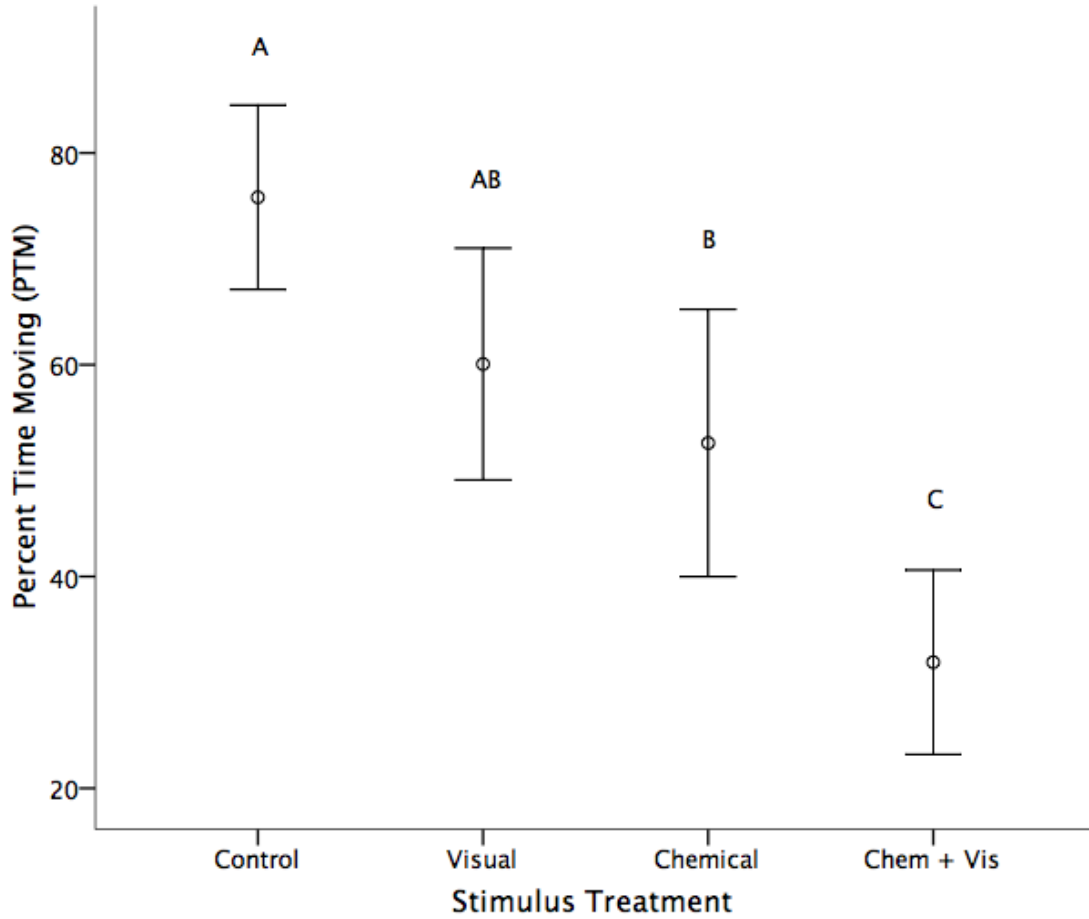

Figure 2. 4. Mean percent time (\pm 95 % CI) spent moving by ingestively naïve neonate mangrove saltmarsh snakes (*Nerodia clarkii compressicauda*) in the presence of four different prey stimulus treatments. Means that do not share superscribed letters are significantly different from each other.

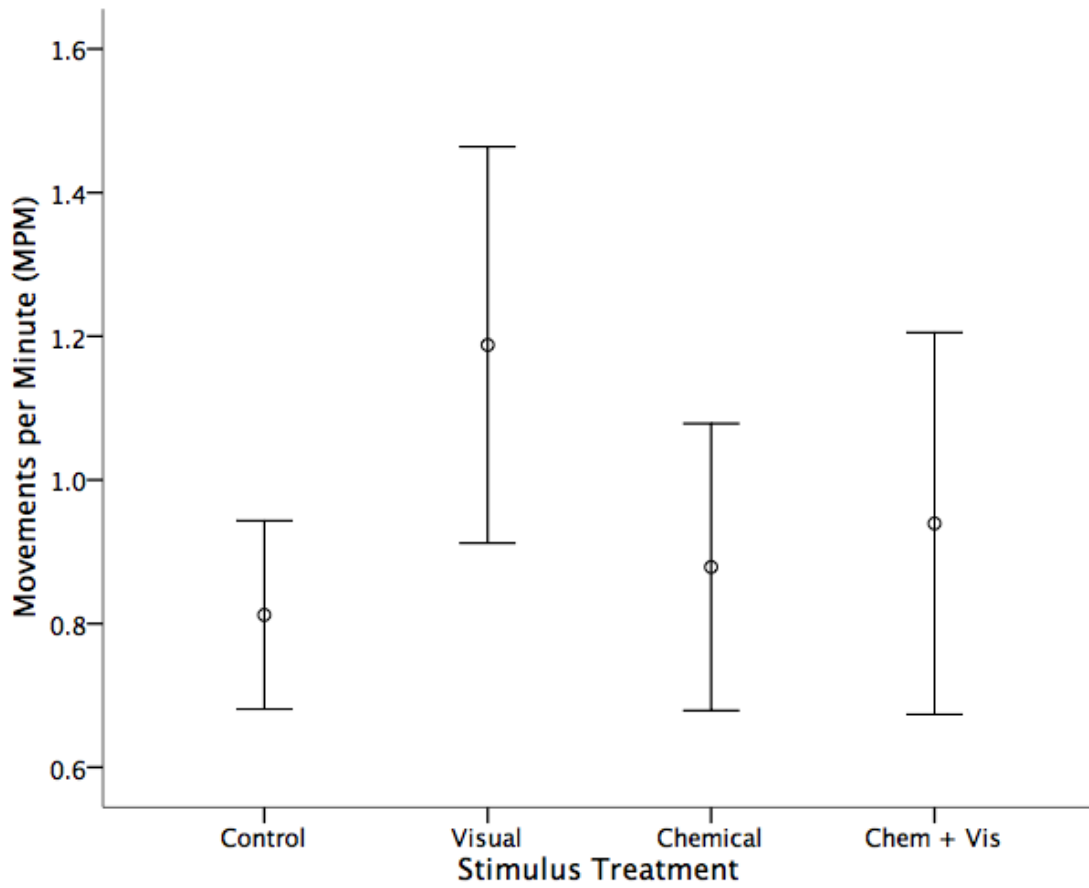

Figure 2. 5. Mean number of movements per minute (\pm 95 % CI) made by ingestively naïve neonate mangrove saltmarsh snakes (*Nerodia clarkii compressicauda*) in the presence of four different prey stimulus treatments.

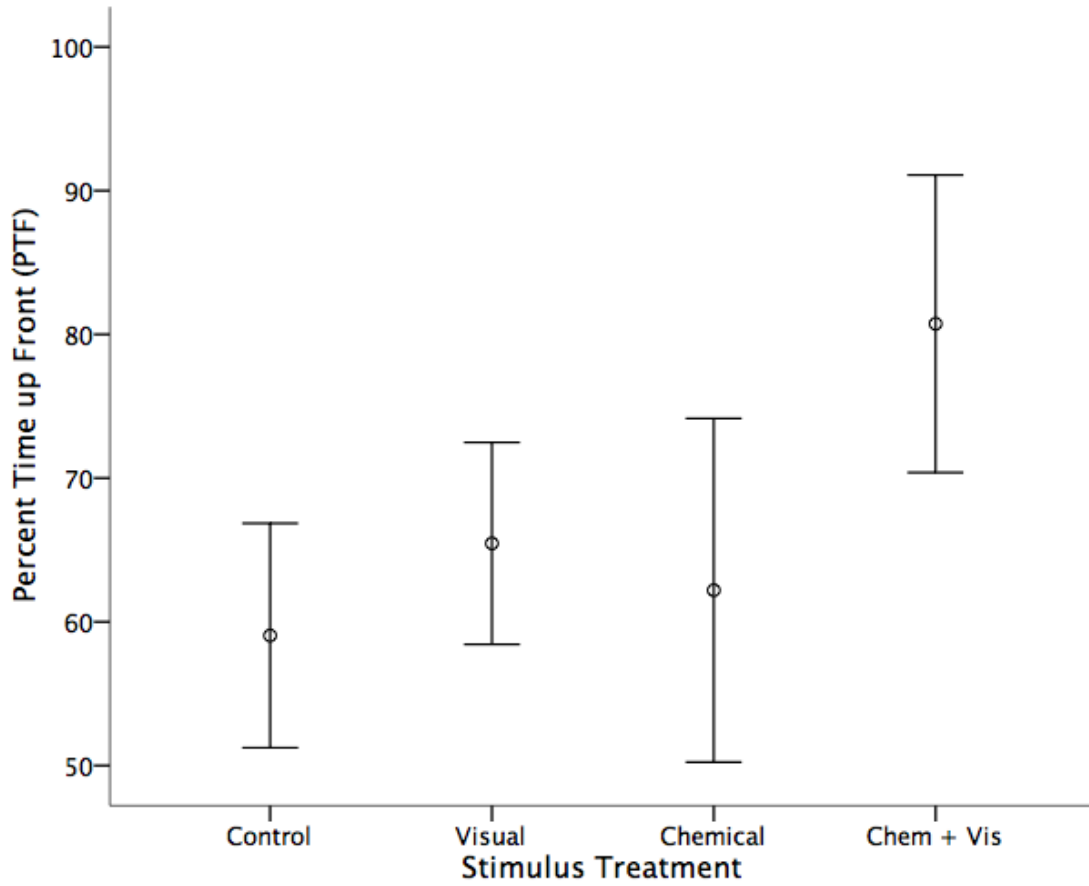

Figure 2. 6. Mean percent time (\pm 95 % CI) spent in the anterior 1/3rd of the test arena (nearest the visual stimulus) by ingestively naïve neonate mangrove saltmarsh snakes (*Nerodia clarkii compressicauda*) in the presence of four different prey stimulus treatments.

**PART 3. EFFECTS OF ECOLOGICAL VARIABLES ON THE FORAGING
BEHAVIOUR OF MANGROVE SALTMARSH SNAKES (*NERODIA CLARKII*
COMPRESSICAUDA)**

This part is a version of a manuscript by the same name submitted for publication in the journal Behaviour in 2009 by Kerry A. Hansknecht.

Abstract

Predators use a variety of strategies and tactics with which to obtain prey, and some predators alter these with changes in ecological conditions. Mangrove saltmarsh snakes are moderately active foragers that occasionally use lingual luring to attract fish prey, a tactic that is decidedly sedentary. I investigated the foraging behavior of mangrove saltmarsh snakes under varying conditions of prey density, habitat structure, and light intensity. Changes in prey density and habitat structural density had no effect on the exhibition of lingual luring by these snakes. However, the frequency of lingual luring was reduced in the dark, indicating that it presents primarily a visual stimulus. Changes in prey density affected the activity level of subjects, which were more active at medium than at low prey density. Changes in habitat structural density affected the location of foraging, with subjects spending more time in water with a higher density of habitat structure. Thus, alterations in the foraging strategy of these snakes depend on which ecological conditions are varying and how. Moreover, changes in foraging mode accompany transitions from one phase of the predation cycle to another.

Introduction

The foraging strategies used by predators have long been classified as being either active or sedentary (Pianka, 1966). Among lizards, which have been studied most extensively in this regard, active predators are typically those that spend more than 10-15% of their foraging time moving about, while the average sedentary predator will spend at least 85% of its foraging time in a stationary position (Cooper, 2005; Butler, 2005). Moreover, predators that prey upon particularly inactive organisms should

themselves be fairly active, while those that prey upon more active organisms are expected to be more sedentary, with the latter relationship being more open to variation (Turnbull, 1973; Huey & Pianka, 1981; Woodward & Hildrew, 2002; Rosenheim & Corbett, 2003; Scharf et al., 2006). The dichotomous view of active and sedentary foraging modes has provided an excellent foundation for many studies of foraging behaviour and ecology (e.g. Huey & Pianka, 1981; Nagy et al., 1984; Evans & O'Brien, 1988; Secor, 1995; Downes & Shine, 1998; Webb et al., 2003). However, there are also many predators that use intermediate foraging modes along a continuum between the active and sedentary extremes (Pietruszka, 1986; McLaughlin, 1989; Perry, 1999; Cooper, 2005), and the inclusion of these provides a much broader, more realistic, and more complex framework for ecological and evolutionary study.

In addition to predators that use a single foraging mode found at one point on the continuum, there are some that alternate between tactics that are largely active and those that are largely sedentary (Helfman, 1990). Such plasticity of foraging behaviour allows predators to succeed in the face of variation in environmental attributes, such as prey density (Formanowicz & Bradley, 1987; Anthony et al., 1992). The effect of prey density on choice of foraging mode is not entirely predictable. Most work thus far has involved predators that employ sedentary, or ambush, tactics when prey density is high and more active tactics when prey density is low (Helfman, 1990; Anthony et al., 1992; Nakano et al., 1999). This flexibility has been proposed to benefit predators by reducing energy expenditure and predation risk at high prey densities and conversely allowing them to trade increased energetic cost and predation risk for an increase in prey encounter rates at low prey densities (Huey & Pianka, 1981; Anthony et al., 1992). Predators that follow the

opposite pattern have also been reported, however (Norberg, 1977; Huey & Pianka, 1981). The argument in these cases is that a predator is benefited by choosing the more costly foraging mode only when prey densities are high and by expending as little energy as possible when food availability is low. This may work well for endotherms, for whom the more costly active foraging tactics might be more effective and, in the end, more efficient (Norberg, 1977). This may not be the case for most ectotherms, however, for whom the costs of active foraging might be outweighed by an increased encounter rate to a greater extent at low prey densities than at high prey densities (Helfman, 1990).

Another ecological variable that has received some attention with respect to foraging-mode plasticity is habitat structure. Submersed vegetation, for example, might obstruct an aquatic predator's view of potential prey or impede its locomotion (Heck & Crowder, 1991), or it might prevent predators from being seen by their prey. Thus, certain foraging modes might be more effective than others in areas where submerged vegetation is more or less abundant. Generally, mode-switching predators use ambush tactics in areas of high structural complexity and active tactics in areas of low structural complexity, and presumably there is a particular level of complexity at which predators are most successful (Savino & Stein, 1982; Ehlinger & Wilson, 1988; James & Heck, 1994; Murray et al., 1995; Mullin & Cooper, 2000).

In addition to choosing an appropriate strategy, a predator must also forage during an appropriate time of day. The times during which a predator forages should coincide with the times that it is likely to encounter prey, and this can depend considerably on the predator's foraging mode as well as the activity level and activity periods of the prey involved. For example, a diurnal predator that takes diurnal prey should be an active

forager if its prey are sedentary. A diurnal predator that takes nocturnal prey, regardless of the latter's foraging strategy or activity level, is also likely to be more active, given that its prey are resting during the day. The same should be true for a nocturnal predator that consumes diurnally active prey; it is expected to operate near the more active end of the foraging-mode continuum.

The Natricinae are a group of snakes ideal for testing hypotheses deriving from such theoretical considerations. They use a wide variety of foraging modes, with some species adopting a single strategy and others exhibiting mode switching (Drummond, 1983; Balent & Andreadis, 1998; Bilcke et al., 2006). One of these, the mangrove saltmarsh snake (*Nerodia clarkii compressicauda*), is a semiaquatic marine piscivore that inhabits red mangrove (*Rhizophora mangle*) forests in Florida, USA, and northern Cuba (Miller & Mushinsky, 1990; Ernst & Ernst, 2003). Mangrove saltmarsh snakes occasionally often employ predatory luring (Hansknecht, 2008), a behavior that, among reptiles at least, is a markedly sedentary tactic that apparently presents a visual stimulus that is attractive to prey (Neill, 1960; Heatwole & Davison, 1976; Drummond & Gordon, 1979). In the marine environment, tidal fluctuations can eliminate pathways used by small fish to enter and leave tidal pools, which can result in changes in prey density at a single location as fish become trapped. This might influence the foraging strategy employed by mangrove saltmarsh snakes. At higher prey densities, these predators might behave as most other ectotherms (Helfman, 1990) and use a sedentary strategy, such as predatory luring. At low prey densities, they might be more active.

Red mangrove trees produce numerous prop roots that provide cover for a wide variety of fishes (Thayer et al., 1987; Mullin, 1995), some of which are hunted by *N. c.*

compressicauda in small pools, lagoons, overwash islands, and forest margins (Miller & Mushinsky, 1990; Mullin, 1995; personal observation). In locations where tidal fluctuations alternately inundate and completely expose these prop roots, the snakes may forage in water bodies characterized by many, few, or no prop roots, and different foraging tactics might be more effective under each condition. If these snakes exhibit foraging-mode switching and follow the trend observed in other aquatic ectotherms (Helfman, 1990), they might use sedentary tactics such as predatory luring more where prop-root density is high and forage more actively where prop-root density is low.

Mangrove saltmarsh snakes are largely nocturnal predators (Ernst & Ernst, 2003; Gibbons & Dorcas, 2004) of predominantly diurnal fish (Bennett, 1973; Batten et al., 1976; Miller & Mushinski, 1990; Benfield & Minello, 1996; Nagelkerken & van der Velde, 2004). As such, they are expected to be fairly active foragers. However, their use of lingual luring, a sedentary tactic that possibly relies on a visual stimulus in order to function, might be restricted to times when there is considerable light available. In order for communication (Burghardt, 1970) to be effective, it must be conducted under conditions in which transmitted signals are likely to be perceived by the target receivers (Bradbury & Vehrencamp, 1998). For example, visual signals that are not themselves light producing are unlikely to be effective in the dark. If the luring tongue flicks exhibited by *N. c. compressicauda* are a visual signal, one would expect them to employ lingual luring primarily, if not exclusively, when there is available light.

The purpose of the present study was to determine the effects of the ecological variables discussed above on the foraging behaviour of *Nerodia clarkii compressicauda*, and I tested the following general hypotheses: Mangrove saltmarsh snakes alter their

activity level and the extent to which they exhibit predatory luring and other foraging behaviours among different levels of (1) prey density and (2) habitat complexity, and (3) they alter the extent to which they exhibit predatory luring and attacks among different levels of prey density.

Experiment I: The Influence of Prey Density

Method

Subjects. Subjects were 25 mangrove saltmarsh snakes (*Nerodia clarkii compressicauda*) from three litters. Sixteen snakes, eight from each of two litters (A and B), were born to wild-caught females from Collier-Seminole State Park, FL. Nine snakes (litter C) were produced from long-term captives of Florida Keys origin that were mated in the laboratory. Subjects were maintained in individual enclosures (18 x 11 x 7 cm) and provided shelter and water ad libitum. Ambient temperature was $25 \pm 1^\circ\text{C}$ and the light:dark cycle was 12:12. Weekly feedings consisted of guppies (*Poecilia reticulata*) or rosy red minnows (*Pimephales promelas*), depending on size and availability. At the time of testing, subjects were approximately 16-18 months old and 23 cm long.

Design. Subjects were tested singly for 12 min in the presence of fish under one of three prey-density conditions: Low (1 guppy; $2.6/\text{m}^2$), Medium (5 guppies; $13/\text{m}^2$), and High (25 guppies; $65/\text{m}^2$). Prey densities were based in part on those found by Mullin (1995) in a mangrove forest populated by *N. c. compressicauda*. Subjects were randomly assigned to one of the three treatments, distributing assignments across litters so that three subjects from each litter were placed into each of the Low ($N = 9$) and High ($N = 9$)

treatment groups, and two subjects from each litter were placed into the Medium ($N = 7$) treatment group.

Apparatus. The test arena was a circular, plastic wading pool 1 m in diameter with an 18-cm tall wall (Figure 3.1A). Eight equally sized bricks were placed flat around the margin of the pool bottom, and these and the entire pool bottom were covered with sand. This created a sloping shoreline that graded into the deeper pool center. A sufficient amount of deionized water to yield a depth of 5 cm in the central area of the pool left a circular strip of exposed substrate (land) 15 cm wide around the arena margin. The pool of water thus had a diameter of 0.7 m and a surface area of 0.385 m². Water depth, shore-area width, and the circular shape of the pool of water were maintained with the aid of the continual reference points provided by the bricks. A continuous length of aluminum flashing was tightly secured around the outer margin of the pool, extending the wall height to 50 cm and preventing subjects from escaping. Trials were recorded using two digital video cameras: a Canon Optura 20 digital video camera mounted 2.5 m above the center of the arena floor and a JVC GR-500U held by hand to track snakes closely enough to observe tongue flicking. The ceiling-mounted camera was connected to a computer that recorded the video as .avi files, while the hand-held camera recordings were made on mini-DV tapes.

Procedure. Before testing began on each day of the experiment, 25 guppies (*Poecilia reticulata*) were left to swim in the arena for 30 min to control for differences in the presence of prey chemical cues earlier versus later in the day. Subjects were moved to the testing room in their home cages approximately 2 min before being carefully transferred to the land swath of the test arena and allowed to acclimate for 2 min. The

observer left the testing room immediately after subject transfer and monitored trials via the hand-held video camera from an adjacent room through a one-way glass wall.

Recording by both cameras was started simultaneously at the end of the 2-min acclimation period. Air temperature was maintained at $24 \pm 1^\circ\text{C}$. Water temperature was maintained at $22 \pm 1^\circ\text{C}$ by making partial water changes between trials, using a hot water bath to warm the deionized water.

Data collection. I used program JWatcher 1.0 (Blumstein et al., 2006) to obtain the following variables from the digital video files: number of attacks, number of captures, percent of time spent moving (PTM), time spent on land, time spent at the shoreline (to 10 cm out), and time spent in the water. The use of conditional states in JWatcher provided the following additional variables: proportion of time spent moving on land, proportion of time spent moving at the shoreline, and proportion of time spent moving in the water. Luring tongue flicks (LTF) were not as easily seen in the video recorded from above the arena, so LTF counts were collected separately from the video tape recordings. A trained observer blind to all hypotheses collected data from all trials of three randomly selected subjects, and reliability exceeded 90%.

Analyses. I used one-way ANOVA to test for overall differences in means for variables that met the assumptions and Fisher's LSD to conduct post-hoc pairwise comparisons. I used the Kruskal-Wallis and Median tests to examine differences among treatments in distributions and medians of variables that failed to meet parametric assumptions and of the numbers of LTFs, attacks, and captures. Nonparametric post-hoc comparisons were made using the Mann-Whitney U test. For all multiple comparisons, I adjusted α using the method of Holm (Aickin & Gensler, 1996).

Results

Activity and location. Across all treatments, subjects spent 41.3 ± 10.5 % (mean \pm 95% CI) of their time moving. PTM differed significantly among the three prey-density treatments (ANOVA $F_{2,22} = 3.55$, $p = 0.046$; Figure 3.2), and post-hoc analysis indicated that it differed significantly between the Low and Medium prey densities (LSD, $p'_{stb} = 0.014$). PTM on land (Low: 28.2 ± 14 %; Medium: 8.79 ± 7.1 %; High: 21.3 ± 17.6 %) differed significantly among the different prey-density groups (Median test $\chi^2_{(2, N=25)} = 6.43$, $p = 0.040$), but post-hoc comparisons failed to detect significant differences between treatments. Snakes averaged 2.7 ± 0.6 movements per minute (MPM), and prey density did not have a significant effect on this (ANOVA $F_{2,22} = 3.83$, $p = 0.686$).

Overall, subjects spent 67.0 ± 10.3 % of their time at the shoreline, 31.1 ± 10.4 % of their time on land, and 1.9 ± 2.3 % of their time in the open water. The proportions of time spent on land, at the shoreline, and in the water did not differ significantly among prey-density treatments.

LTFs, attacks, and captures. The different prey-density treatment groups did not differ in distribution or median of the number of luring tongue flicks (Kruskal-Wallis test $\chi^2_{(2, N=25)} = 0.571$, $p = 0.752$; Median test $\chi^2_{(2, N=25)} = 0.277$, $p = 0.871$), attacks (Kruskal-Wallis test $\chi^2_{(2, N=25)} = 3.237$, $p = 0.198$; Median test $\chi^2_{(2, N=25)} = 1.074$, $p = 0.585$), or captures (Kruskal-Wallis test $\chi^2_{(2, N=25)} = 2.753$, $p = 0.252$; Median test $\chi^2_{(2, N=25)} = 2.797$, $p = 0.247$; Figure 3.3).

Discussion

Mangrove saltmarsh snakes were fairly active under the conditions in which they were tested. Lizards are generally considered active foragers if they spend 10-15% or more of their time moving and move more than once per minute (Butler, 2005; Cooper, 2005). The snakes examined here moved more than twice that much. Subjects spent most of their time along the shoreline, and at a medium prey density they were relatively sedentary. At the low prey density, snakes were much more active. This agrees with what others have found among ectothermic vertebrates (Helfman, 1990; Anthony et al., 1992; Nakano et al., 1999). Moreover, movement on land accounted for a large part of the activity in the Low condition. This may be an indication that the subjects were seeking alternate foraging sites and thus not only making a slight shift in foraging mode but also transitioning between the search and pursuit phases of the predation cycle (Curio, 1976; Helfman, 1990).

The lack of a significant difference in the number of luring tongue flicks exhibited between different prey-density treatments was partly driven by the relatively low frequency of the behaviour. However, it was also influenced by some snakes tending to lure at every opportunity, provided there was some indication of the presence of prey. The inter-individual variation in luring tendency thus manifested itself as inter-individual variation in mode-switching tendency, and it also suggests there are individual preferences for particular foraging strategies. Also, the average number of LTFs exceeded the number of attacks in only the Medium treatment. While the effect was not significant, its contrast with the patterns in the Low and High treatments suggests that there might be an optimal prey density at which to use lingual luring.

The similarity of the numbers of both captures and attacks between treatments is interesting, especially given the very high density of fish used in the High treatment. Some have suggested that ectothermic predators might forage in such a way as to maintain a particular encounter rate (Helfman, 1990), and this could explain the result here. However, I did not measure encounter rates directly. Moreover, subjects were often surrounded by half the fish or more, and attacks during these times were rare. Prey swarming (Ruxton et al., 2007; Jeschke & Tollrian, 2007) may therefore have been in operation.

Experiment II: The Influence of Habitat Structure

Method

Subjects. Subjects were 24 mangrove saltmarsh snakes (*Nerodia clarkii compressicauda*), the same snakes used in Experiment I except that only eight snakes from Litter C were used. At the time of testing, subjects were approximately 18-20 months old.

Design. Subjects were tested singly in the presence of fish for 15 minutes under each of three simulated prop-root densities: Low (0 roots; 0 m⁻²), Medium (15 roots; 30 m⁻²), and High (30 roots; 60 m⁻²). The Medium and High treatments are representative of mean and extreme densities that occur in the field (Mullin, 1995; personal observation). Subjects were randomly assigned to one of six possible test orders, which were balanced across litters and sexes.

Apparatus. The test arena was a circular, plastic wading pool 1 m in diameter with an 18-cm tall wall (Figure 3.1B). Aluminum flashing secured tightly around the entire perimeter of the arena extended the wall height to 50 cm to prevent subjects from

escaping. Sand was used as substrate and was shaped to create a sloping shoreline. In the center of the arena was buried a 0.8-m diameter circular piece of plastic lighting louver (Plaskolite, Inc.) that had square cells 1.9 cm wide. These cells would securely accommodate 1.9-cm diameter wooden dowel, which was used to simulate mangrove prop roots. The 1802 cells of this plastic grid were numbered around its margin and center to facilitate random placement of the dowels. A duplicate grid was constructed to permit proper location of dowels while the supporting grid was buried. Deionized water was added to yield a pool 0.8 m wide (0.5 m^2) and 4 cm deep in the central area of the arena. A circular strip of unexposed sand substrate 10 cm wide surrounded the pool of water.

Trials were recorded using two digital video cameras: a Canon Optura 20 digital video camera mounted 2.5 m above the center of the arena floor and a JVC GR-500U held by hand to track snakes closely enough to observe luring tongue flicks. The ceiling-mounted camera was connected to a computer that recorded the video as .avi files, while the hand-held camera recordings were made on mini-DV tapes.

Procedure. Five min prior to each trial, three guppies were placed into the arena. Subjects were moved to the testing room in their home cages approximately 2 min before being carefully transferred to the land swath of the test arena. The observer left the testing room immediately after subject transfer and began monitoring trials via the hand-held video camera from an adjacent room through a one-way glass wall. Recording by both cameras was started simultaneously. Video recording of one group of eight trials was not initiated until 2 minutes after placement of the subject. Therefore, the first two minutes following subject placement were not used to obtain data from any trial; trial duration

was thus 13 minutes. Air temperature was maintained at $24 \pm 1^\circ\text{C}$. Water temperature was maintained at $22 \pm 1^\circ\text{C}$ by making partial water changes between trials, using a hot water bath to warm the deionized water.

Data collection and analysis. Program JWatcher 1.0 (Blumstein et al., 2006) was used to record the following variables from video-recordings of trials: number of attacks, number of captures, time spent moving, and time spent in the open water, at the shoreline (to 10-cm out), and on the land area. Additional variables (movement by location) were obtained from JWatcher using the conditional states option. Encounters with fish (every fish coming within a 6-cm radius of the subject's snout) were scored manually. Distance measurement was achieved by video recording a large 2-cm grid placed in the arena and drawing a 6-cm circle onto a piece of clear plastic sheet using the grid as a guide. Luring tongue flicks (LTF) were scored from tapes recorded using the hand-held camcorder. Reliability estimates matched those of Experiment I. I used repeated measures ANOVA to test for differences between treatment groups and followed the recommendation of Quinn & Keough (2002) by examining both the univariate and multivariate tests, rejecting H_0 if either result indicated significance. For post-hoc pairwise comparisons, I used Fisher's *LSD* and corrected α using the method of Holm (Aickin & Gensler, 1996).

Results

Subjects spent 44.9 ± 12.3 % (mean \pm 95% CI) of their time moving (PTM) during trials at the Low (0 m^{-2}) prop-root density, 32.0 ± 11.2 % at the Medium (30 m^{-2}) prop-root density, and 36.0 ± 10.8 % at the High (60 m^{-2}) prop-root density. PTM did not differ significantly between treatments (Table 3.1). Among other movement variables

examined, only PTM in the water differed significantly among treatments (Figure 3.4; Table 1). Post-hoc comparisons were significant between PTM in the Low and Medium ($LSD, p'_{stb} = 0.020$) and Low and High ($LSD, p'_{stb} = 0.015$) prop root densities.

The percent of time subjects spent in the water differed significantly between different prop-root densities (Table 3.2; Figure 3.5), and post-hoc analysis indicated there was a significant difference between the Low and High treatments ($LSD, p'_{stb} = 0.015$). The average duration of visits made by snakes into the open water also differed significantly between prop-root density levels (Table 3.2; Figure 3.6), but no pairwise differences were significant. No significant differences were found in usage of the land or shore areas among treatments (Table 3.2). The numbers of encounters with fish, luring tongue flicks, attacks upon fish, and captures did not differ significantly between prop-root density treatments (Table 3.3; Figure 3.7).

Discussion

Mangrove saltmarsh snakes spent very little time in the offshore water in the absence of structure and significantly more time there when artificial prop roots were present. On the few occasions the subjects did enter offshore waters, the duration of those trips was significantly shorter in the absence of emergent structure. A number of factors might contribute to this relationship. Given that the snakes have predators of their own, the simulated prop roots could have provided a small amount of protective cover for them (Main, 1987), perhaps making them more inclined to venture out away from the shore. In addition to any function such structure might serve to obscure potential prey from the view of predators (Heck & Crowder, 1991), increases in habitat structure have also been

found to impede predator movements (Nelson, 1979). In open water without dense assemblages of prop roots, a snake such as *N. c. compressicauda* would be easy prey for any of a number of large fish, as well as crocodilians, that occur in the waters surrounding their habitat. Where prop roots occur, however, such risk is likely reduced, leaving the snakes to move about more freely.

From another perspective, the considerable structure provided by mangroves has long been appreciated as ideal refuge for smaller fish from larger ones (Thayer et al., 1987). Though I did not track their movements, the fish in this experiment might themselves have been moving about more in those treatments endowed with some level of structural complexity. An increased activity level on the part of the prey would be well matched for a more sedentary mode of foraging on the part of the predator (Huey & Pianka, 1981), and the relatively small amount of time the subjects spent moving in the intermediate-density treatment followed this pattern. Moving less, and expending less energy, while attaining higher encounter rates should almost certainly be beneficial, especially if it is accompanied by a reduction in predation risk. In a similar study, Mullin & Mushinsky (1995) found that adult *N. c. compressicauda* remained perched and stationary most of the time, and changes in habitat structural density did not affect the activity level or capture success of the snakes. Thus, instead of influencing prey fish activity, increased structure might impair the snakes' ability to pursue fish, making a sedentary strategy the most efficient.

In the treatment without simulated prop roots, a great deal of time was spent in the land areas. In addition to partly explaining lower encounter rates in that treatment, this could indicate a slight mode shift from a somewhat sedentary to a more active strategy.

At the same time, it seems likely that this is representative of a transition between the search and pursuit phases of the predation cycle (Curio, 1976; Helfman, 1990). Many of the predators studied with regard to foraging-mode switching and the influence of habitat structure have been fully aquatic (Heck & Crowder, 1991). Such animals that cannot leave the water may be shifting between phases of the predation cycle in many cases, rather than only changing foraging modes. An amphibious creature such as a watersnake, however, might serve as a better model with which to study such transitions, as a move from the water to land might be easier to identify than a move from slightly deep to moderately deep water.

Experiment III: The Influence of Light Intensity

Method

Subjects. Subjects were 24 mangrove saltmarsh snakes (*Nerodia clarkii compressicauda*) taken from five litters of Florida Keys origin. Fifteen snakes were born to long-term captives mated in the laboratory. Nine of these were from a litter (C) used in Experiments I and II, and six were from a different captive-bred litter (D). Nine snakes, four from each of two litters (E and F) and one from a third (G), were born to wild-caught females. Subjects were maintained as described for Experiment I. At the time of testing, litter C was approximately six months old, while all other subjects were approximately 18 months old.

Design. Subjects were tested singly for 15 min in the presence of fish under each of four light-intensity conditions: Dark (0.92 lx), Low (3.2 lx), Medium (82.6 lx), and High (377 lx). Light measurements were made in the center of the arena floor using a LI-COR LI-250A handheld light meter and LI-190 quantum sensor and converted from

$\mu\text{mol s}^{-1} \text{ m}^{-2}$ to lx. Each subject was randomly assigned to one of six possible treatment orders involving the Low, Medium, and High treatments. Treatment orders were balanced across litters and sexes to the extent possible. Initially, the design included only three treatments. However, after experiments were underway, it became apparent that an even darker treatment was desirable. Thus, a fourth treatment was added, and all subjects were tested in the Dark condition last.

Apparatus.

Test arena I. The 18-month-old subjects ($N = 15$) were tested in a 30.5 x 30.5 x 29-cm clear plexiglas arena (Figure 3.8A) containing deionized water 3 cm deep. A clear plexiglas divider created a chamber 4 cm wide along one side of the arena where fish could be presented without being captured during trials. Near the bottom of this divider, a 26 x 4-cm window was cut out and covered with mesh screen. This permitted chemical, tactile, and visual prey cues to pass freely to the larger section of the arena. The entire arena was surrounded by gray construction paper in order to reduce external visual stimuli that might distract subjects from prey in the chamber.

Test arena II. The six-month-old subjects ($N = 9$) were tested in a 20 x 20 x 25-cm chamber (Figure 3.8B) that was half of a subdivided 21-l glass aquarium. The floor of the chamber was textured (Hansknecht & McDonald, 2009) to improve the locomotory ability of the subjects, and the arena contained deionized water to a depth of 2 cm during trials. A longitudinally bisected 11.5-cm length of gray pvc tubing (1.9-cm inside diameter) affixed to a flat base with its inner surface facing upward provided an anchorage/ambush site for the subjects, and the entire inside surface of the arena was painted opaque medium gray.

General. Trials were recorded using a Sony DCR-TRV320 digital video camera mounted 0.75 m above the center of the arena floor. In the Low and Dark trials, the infrared reception capabilities of the camcorder were used, and infrared illumination of the arena was achieved by mounting eight infrared LEDs around a square frame suspended above the test chamber. This frame was in position with the LEDs turned on for all trials, regardless of treatment.

Procedure. Subjects were tested during the early to late afternoon on days and times that fell on their normal feeding schedule. Prior to moving subjects into the testing room, rosy red minnows (*Pimephales promelas*) were transferred into the test arena. For tests conducted using Arena I, five minnows were placed into the side chamber and out of reach of the snakes. Arena II had no such isolating chamber, and the fish could contact and be captured by the snakes. Thus, for tests in Arena II, only three minnows were used. In order to prevent satiation and reduced responses by these subjects, as well as disturbance during the tests, fish were replaced as captured only if the remaining minnows appeared too inactive for the snakes to detect their movements.

Subjects were moved to the testing room in their home cages approximately 2 min before the start of trials, at which point they were carefully transferred from their home cage to the center of the test arena and allowed to acclimate for 2 min. Observers left the testing room immediately after subject transfer and only re-entered the room to replace fish eaten during trials conducted using Arena II, remaining out of view of the subjects during the process. Trials were monitored from an adjacent room either through a one-way glass wall or on a computer connected to the video camera. Test arenas were rinsed thoroughly between each trial. Air and water temperatures were maintained at $24 \pm 1^\circ\text{C}$.

Data collection and analysis. Video-recordings of trials were reviewed for LTFs and attacks, and analyses were conducted separately for six-month-old subjects (tested using Arena II) and 18-month-old subjects (tested using Arena I). Reliability estimates matched those of Experiment I. I used Friedman's test to examine the hypotheses that the numbers of LTFs and attacks were equal across light-intensity treatments and Cochran's test to examine the hypothesis that the number of snakes that lured was equal across treatments. I used Page's test to detect trends in LTF and attack frequencies related to the increase in light intensity. For post hoc analyses, I used Wilcoxon signed rank tests following Friedman's tests and McNemar tests following Cochran's test, and I compared p to α' as calculated using Holm's stepwise adjustment of α , which was initially set at 0.05. Estimates of effect size, Cohen's d , were calculated following Dunlap et al. (1996).

Results

Luring tongue flicks exhibited by six-month-old snakes (Arena II). There was no significant difference in the number of six-month old subjects that lured under the different light-intensity treatments (Cochran's test $Q = 6.0$, $N = 9$, d.f. = 3, $p = 0.112$; Figure 3.9). However, the number of LTFs exhibited under the different light intensities did differ significantly (Friedman's test $\chi^2_{(3, N=9)} = 8.02$, $p = 0.046$; Figure 3.10). After correction of α for multiple comparisons, Wilcoxon signed ranks tests failed to detect significant differences between any two conditions. The difference in mean LTF frequencies between the Dark and Low treatments was moderately large (Cohen's $d = 0.73$). Effect size estimates for all other pairwise comparisons were small (Cohen's $d < 0.5$). Page's test for ordered alternatives detected no significant trend involving luring frequency and light intensity among the six-month-old snakes.

Attacks exhibited by six-month-old snakes (Arena II). The number of six-month-old subjects that attacked fish did not differ between treatments (all snakes issued attacks during all trials), nor did the number of attacks made by snakes under the different light conditions (Friedman's test $\chi^2_{(3, N=9)} = 1.15, p = 0.765$; Figure 3.11). Effect sizes for the pairwise comparisons were all small (Cohen's $d < 0.5$). Page's test detected no significant trend involving attack frequency and light intensity.

Luring tongue flicks exhibited by 18-month-old snakes (Arena I). The number of 18-month old snakes that lured under the different light-intensity treatments differed significantly (Cochran's test $Q = 8.08, N = 15, \text{d.f.} = 3, p = 0.044$; Figure 3.12), but McNemar's tests failed to demonstrate any significant differences between different treatments. The number of LTFs exhibited by the 18-month-old snakes under the different light intensities differed significantly (Friedman's test $\chi^2_{(3, N=15)} = 8.83, p = 0.032$; Figure 3.13), but Wilcoxon signed ranks tests failed to detect significant differences between any two conditions. Effect sizes for the pairwise comparisons were all small (Cohen's $d < 0.5$). Page's test detected a significant trend involving luring frequency and light intensity, the former increasing with the latter, among the 18-month-old snakes ($Z_L = 6.93, p < 0.001$).

Attacks exhibited by 18-month-old snakes (Arena I). The number of 18-month-old snakes that issued attacks during trials did not differ significantly between treatments (Cochran's test $Q = 6.67, N = 15, \text{d.f.} = 3, p = 0.083$), nor did the number of attacks made by the subjects (Friedman's test $\chi^2_{(3, N=15)} = 7.03, p = 0.071$; Figure 3.14). Effect sizes for the pairwise comparisons were all small (Cohen's $d < 0.5$). Page's test detected a

significant trend involving attack frequency and light intensity, the former increasing with the latter, among the 18-month-old snakes ($Z_L = 5.81, p < 0.001$).

Discussion

Very little lingual luring was exhibited in the darkest light conditions used here, which indicates that the luring tongue flick of *Nerodia clarkii compressicauda* is primarily a visual signal. Moreover, it suggests that these snakes likely use predatory luring during the daylight hours and are not strictly nocturnal foragers. This agrees well with what little dietary information exists for these snakes, as their primary prey (*Cyprinodon variegatus*, *Poecilia latipinna*, *Fundulus similis*, and *F. grandis*; Miller & Mushinsky, 1990) are diurnal foragers (Bennett, 1973; Batten et al., 1976; Nagelkerken & van der Velde, 2004). While it is possible that the administration of Dark trials last for all individuals might have influenced responding, one would expect that increased luring would occur in these trials as subjects acclimated to the testing environment. However, this was not the case. Furthermore, the Dark-condition responses often matched the trend observed in the other conditions.

Some luring was observed in dark conditions. Invariate adherence by animals to a single diel activity schedule is likely uncommon (Gibbons & Semlitsch, 1987; Reeb, 2002), and many fish that are rather strictly diurnal, for example, will at least occasionally break from this pattern and forage at night (Bennett, 1973; Reeb, 2002). Thus, these snakes could also benefit from using this sedentary tactic outside of the daylight hours. The generally good low light visual sensitivity of fish (Benfield & Minello, 1996; Utne, 1997; Rader et al., 2007) may enable them to see the tongue of these snakes at dusk and afterward, especially with the aid of moonlight. In addition, it

has been posited that tactics such as this one that rely on visual deception (excepting luminous lures) function best in low to moderate light (Neill, 1960).

Both age and experimental design could have contributed to the slight difference in LTF exhibition between the two groups of subjects, especially at the lowest light intensity (the Dark treatment). Younger mangrove saltmarsh snakes appear more inclined to exhibit lingual luring than older individuals (personal observation), and ontogenetic shifts in predatory luring are well documented (Greene & Campbell, 1972; Heatwole & Davison, 1976; Welsh & Lind, 2000). Also, the younger snakes tested here had full access to the fish, and this likely provided those subjects with a more powerful suite of prey stimuli than might have been available to the older subjects. Tactile cues may have been especially important in the darkest treatment, during which none of the subjects tested in Arena I lured. The screen barrier in Arena I likely did not reduce chemical cues appreciably, but direct contact between the snakes and the fish was prevented. The low number of attacks issued by older snakes is further indication that the barrier reduced releasing stimuli to some extent, while the significant linear trend of increased LTFs with increasing light intensity exhibited by snakes tested in Arena I suggests that greater illumination may have served to compensate for any barrier-reduced visual, tactile, and chemical cues.

The notable difference in the relationships between light intensity and the numbers of attacks and LTFs issued by subjects tested in Arena II (Figures 3.10 and 3.11) suggests a difference in the importance of visual and tactile stimuli to those two behaviours. Vision appears to be of considerable importance to lingual luring by *N. c. compressicauda* (Part 2), while equal numbers of attacks toward fish at all light levels indicate that tactile cues

are particularly important for prey capture, especially in the dark. Other studies have drawn similar conclusions (Reiserer, 2002; Shine et al., 2004). Each type of stimulus likely contributes to both behaviours, however, as tactile stimuli may have been largely responsible for eliciting luring in the Dark treatment here, and visual stimuli have been shown to be important to other aspects of foraging (Czaplicki & Porter, 1974; Drummond, 1979, 1985).

In addition to Neill's (1960) anecdotal observations, only two other studies have investigated the influence of light intensity on predatory luring by snakes. Chiszar et al. (1990) observed four adult southern death adders (*Acanthophis antarcticus*) in the absence of prey during the day under lighted conditions and at night in the dark (except for a red incandescent light source presumably invisible to the snakes). They found that when prey were not present, *A. antarcticus* exhibited caudal luring almost exclusively at night in the dark. However, in the same article, they report frequent caudal luring by *A. antarcticus* during different experiments conducted in the daytime in the presence of prey. Rabatsky & Farrell (1996) examined the use of caudal luring by 20 juvenile dusky pigmy rattlesnakes (*Sistrurus miliarius barbouri*) under four different conditions of light intensity (1.9, 2.7, 64.5, and 333.7 lx) in the presence of prey, and they found no effect of light intensity on the frequency of caudal luring by their subjects. Both *A. antarcticus* and *S. m. barbouri* are sedentary predators that consume multiple prey types, some nocturnal and some diurnal, while *N. c. compressicauda* feed only on fish that are largely diurnal. This could account for the difference in results between the present study and those of Chiszar et al. and Rabatsky & Farrell.

Mangrove saltmarsh snakes seem capable of foraging successfully in a variety of light conditions. However, they may use different foraging strategies at different periods in the daily cycle. In the daytime, when their prey are active, they may use a more sedentary strategy, including such tactics as lingual luring. At night, however, they might be more inclined to forage more actively while their prey rest, and they may rely more heavily on tactile cues at these times.

Literature Cited

- Aickin, M., and H. Gensler. 1996. Adjusting for multiple testing when reporting research results: the Bonferroni vs Holm methods. *American Journal of Public Health* 86:726-728.
- Anthony, C. D., D. R. Formanowicz, Jr., and E. D. Brodie, Jr. 1992. The effect of prey availability on the search behavior of two species of Chinese salamanders. *Herpetologica* 48:287-292.
- Balent, K. L., and P. T. Andreadis. 1998. The mixed foraging strategy of juvenile northern water snakes. *Journal of Herpetology* 32:575-579.
- Batten, T. F. C., J. N. Ball, and H. J. Grier. 1976. Circadian changes in prolactin cell activity in the pituitary of the teleost *Poecilia latipinna* in freshwater. *Cell and Tissue Research* 165:267-280.
- Benfield, M. C., and T. J. Minello. 1996. Relative effects of turbidity and light intensity on reactive distance and feeding of an estuarine fish. *Environmental Biology of Fishes* 46:211-216.
- Bennett, J. A. 1973. Food habits and feeding chronology of the long nose killifish *Fundulus similis* (Baird and Girard) from St. Louis Bay, Mississippi. Unpubl. Unpublished MS thesis, Mississippi State University.
- Bilcke, J., A. Herrel, and R. Van Damme. 2006. Correlated evolution of aquatic prey-capture strategies in European and American natricine snakes. *Biological Journal of the Linnean Society* 88:73-83.
- Bradbury, J. W., and S. L. Vehrencamp. 1998. Principles of animal communication. Sinauer Associates

- Burghardt, G. M. 1970a. Defining communication. *In* J. W. Johnston, D. C. Moulton, Jr., and A. Turk (eds.), *Communication by chemical signals*, pp. 5–18. Appleton-Century-Crofts, New York.
- 1970b. Chemical perception in reptiles. *In* J. W. Johnston, D. C. Moulton, Jr., and A. Turk (eds.), *Communication by chemical signals*, pp. 241–308. Appleton-Century-Crofts, New York.
- Butler, M. A. 2005. Foraging mode of the chameleon, *Bradypodion pumilum*: a challenge to the sit-and-wait versus active forager paradigm? *Biological Journal of the Linnean Society* 84:797-808.
- Chiszar, D., D. Boyer, R. Lee, J. B. Murphy, and C. W. Radcliffe. 1990. Caudal luring in the southern death adder, *Acanthophis antarcticus*. *Journal of Herpetology* 24:253-260.
- Cooper, W. E. 2005. The foraging mode controversy: both continuous variation and clustering of foraging movements occur. *Journal of Zoology* 267:179-190.
- Curio, E. 1976. *The ethology of predation*. Springer-Verlag, Berlin.
- Czaplicki, J. A., and R. H. Porter. 1974. Visual cues mediating the selection of goldfish (*Carassius auratus*) by two species of *Natrix*. *Journal of Herpetology* 8:129-134.
- Downes, S., and R. Shine. 1998. Sedentary snakes and gullible geckos: predator-prey coevolution in nocturnal rock-dwelling reptiles. *Animal Behaviour* 55:1373-1385.
- Drummond, H. 1983. Aquatic foraging in garter snakes: a comparison of specialists and generalists. *Behaviour* 86:1-30.
- 1985. The role of vision in the predatory behavior of natricine snakes. *Animal Behaviour* 33:206-215.

- Drummond, H., and E. R. Gordon. 1979. Luring in the neonate alligator snapping turtle (*Macroclemys temminckii*): description and experimental analysis. *Zeitschrift für Tierpsychologie* 50:136-152.
- Drummond, H. M. 1979. Stimulus control of amphibious predation in the northern water snake (*Nerodia s.sipedon*). *Zeitschrift für Tierpsychologie* 50:18-44.
- Dunlap, W. P., J. M. Cortina, J. B. Vaslow, and M. J. Burke. 1996. Meta-analysis of experiments with matched groups or repeated measures designs. *Psychological Methods* 1:170-177.
- Ehlinger, T. J., and D. S. Wilson. 1988. Complex foraging polymorphism in bluegill sunfish. *Proceedings of the National Academy of Sciences of the United States of America* 85:1878-1882.
- Ernst, C. H., and E. M. Ernst. 2003. *Snakes of the United States and Canada*. Smithsonian Books, Washington, D.C.
- Evans, B. I., and W. J. O'Brien. 1988. A reevaluation of the search cycle of planktivorous arctic grayling, *Thymallus arcticus*. *Canadian Journal of Fisheries and Aquatic Sciences* 45:187-192.
- Formanowicz, D. R., Jr., and P. J. Bradley. 1987. Fluctuations in prey density: effects on the foraging tactics of scolopendrid centipedes. *Animal Behaviour* 35:453-461.
- Gibbons, J. W., and M. E. Dorcas. 2004. *North American watersnakes: a natural history*. University of Oklahoma Press, Norman.
- Gibbons, J. W., and R. D. Semlitsch. 2001. Activity Patterns. *In* R. A. Seigel, J. T. Collins, and S. S. Novack (eds.), *Snakes: Ecology and Evolutionary Biology*, pp. 396-421. The Blackburn Press.

- Greene, H. W., and J. A. Campbell. 1972. Notes on the use of caudal lures by arboreal green pit vipers. *Herpetologica* 28:32-34.
- Hansknecht, K. A. 2008. Lingual luring by mangrove saltmarsh snakes (*Nerodia clarkii compressicauda*). *Journal of Herpetology* 42:9-15.
- Heatwole, H., and E. Davison. 1976. A review of caudal luring in snakes with notes on its occurrence in the Saharan sand viper, *Cerastes vipera*. *Herpetologica* 32:332-336.
- Heck, K. L., Jr., and L. B. Crowder. 1991. Habitat structure and predator-prey interactions in vegetated aquatic systems. *In* S. S. Bell, E. D. McCoy, and H. R. Mushinsky (eds.), *Habitat Structure: The physical arrangement of objects in space*, pp. 281-299. Chapman and Hall, London.
- Helfman, G. S. 1990. Mode selection and mode switching in foraging animals. *In* P. J. B. Slater, J. S. Rosenblatt, and C. Beer (eds.), *Advances in the Study of Behavior*, Vol. 19, pp. 249-298. Academic Press, San Diego.
- Huey, R. B., and E. R. Pianka. 1981. Ecological consequences of foraging mode. *Ecology* 62:991-999.
- James, P. L., and K. L. Heck. 1994. The effects of habitat complexity and light intensity on ambush predation within a simulated seagrass habitat. *Journal of Experimental Marine Biology and Ecology* 176:187-200.
- Jeschke, J. M., and R. Tollrian. 2007. Prey swarming: which predators become confused and why? *Animal Behaviour* 74:387-393.
- Main, K. L. 1987. Predator avoidance in seagrass meadows: prey behavior, microhabitat selection, and cryptic coloration. *Ecology* 68:170-180.

- McLaughlin, R. L. 1989. Search modes of birds and lizards: evidence for alternative movement patterns. *American Naturalist* 133:654-670.
- Miller, D. E., and H. R. Mushinsky. 1990. Foraging ecology and prey size in the mangrove water snake, *Nerodia fasciata compressicauda*. *Copeia* 1990:1099-1106.
- Mullin, S. J. 1995. Estuarine fish populations among red mangrove prop roots of small overwash islands. *Wetlands* 15:324-329.
- Mullin, S. J., and R. J. Cooper. 2000. The foraging ecology of the gray rat snake (*Elaphe obsoleta spiloides*). II. Influence of habitat structural complexity when searching for arboreal avian prey. *Amphibia-Reptilia* 21:211-222.
- Mullin, S. J., and H. R. Mushinsky. 1995. Foraging ecology of the mangrove salt marsh snake, *Nerodia clarkii compressicauda*: effects of vegetational density. *Amphibia-Reptilia* 16:167-175.
- Murray, D. L., S. Boutin, M. Odonoghue, and V. O. Nams. 1995. Hunting behavior of a sympatric felid and canid in relation to vegetative cover. *Animal Behaviour* 50:1203-1210.
- Nagelkerken, I., and G. van der Velde. 2004. A comparison of fish communities of subtidal seagrass beds and sandy seabeds in 13 marine embayments of a Caribbean island, based on species, families, size distribution and functional groups. *Journal of Sea Research* 52:127-147.
- Nagy, K. A., R. B. Huey, and A. F. Bennett. 1984. Field energetics and foraging mode of Kalahari lacertid lizards. *Ecology* 65:588-596.

- Nakano, S., K. D. Fausch, and S. Kitano. 1999. Flexible niche partitioning via a foraging mode shift: a proposed mechanism for coexistence in stream-dwelling charrs. *Journal of Animal Ecology* 68:1079-1092.
- Neill, W. T., Jr. 1960. The caudal lure of various juvenile snakes. *Quarterly Journal of the Florida Academy of Sciences* 23:173-200.
- Nelson, W. G. 1979. Experimental studies of selective predation on amphipods: consequences for amphipod distribution and abundance. *Journal of Experimental Marine Biology and Ecology* 38:225-245.
- Norberg, R. Å. 1977. An ecological theory on foraging time and energetics and choice of optimal food-searching method. *Journal of Animal Ecology* 46:511-529.
- Perry, G. 1999. The evolution of search modes: ecological versus phylogenetic perspectives. *American Naturalist* 153:98-109.
- Pianka, E. R. 1966. Convexity, desert lizards, and spatial heterogeneity. *Ecology* 47:1055-1059.
- Pietruszka, R. D. 1986. Search tactics of desert lizards: how polarized are they? *Animal Behaviour* 34:1742-1758.
- Quinn, G. P., and M. J. Keough. 2002. *Experimental design and data analysis for biologists* Cambridge University Press, Cambridge.
- Rabatsky, A. M., and T. M. Farrell. 1996. The effects of age and light level on foraging posture and frequency of caudal luring in the rattlesnake, *Sistrurus miliarius barbouri*. *Journal of Herpetology* 30:558-561.

- Rader, R. B., T. Belish, M. K. Young, and J. Rothlisberger. 2007. The scotopic visual sensitivity of four species of trout: a comparative Study. *Western North American Naturalist* 67:524-537.
- Reebs, S. G. 2002. Plasticity of diel and circadian activity rhythms in fishes. *Reviews in Fish Biology and Fisheries* 12:349-371.
- Reiserer, R. S. 2002. Stimulus control of caudal luring and other feeding responses: a program for research on visual perception in vipers. *In* G. W. Schuett, M. Höggren, M. E. Douglas, and H. W. Greene (eds.), *Biology of the Vipers*, pp. 363-383. Eagle Mountain Publishing, Eagle Mountain, UT.
- Rosenheim, J. A., and A. Corbett. 2003. Omnivory and the indeterminacy of predator function: can a knowledge of foraging behavior help? *Ecology* 84:2538-2548.
- Ruxton, G. D., A. L. Jackson, and C. R. Tosh. 2007. Confusion of predators does not rely on specialist coordinated behavior. *Behavioral Ecology* 18:590-596.
- Savino, J. F., and R. A. Stein. 1982. Predator-prey interaction between largemouth bass and bluegills as influenced by simulated, submersed vegetation. *Transactions of the American Fisheries Society* 111:255-266.
- Scharf, I., E. Nulman, O. Ovadia, and A. Bouskila. 2006. Efficiency evaluation of two competing foraging modes under different conditions. *American Naturalist* 168:350-357.
- Secor, S. M. 1995. Ecological aspects of foraging mode for the snakes *Crotalus cerastes* and *Masticophis flagellum*. *Herpetological Monographs* 9:169-186.

- Shine, R., G. P. Brown, and M. J. Elphick. 2004. Field experiments on foraging in free-ranging water snakes *Enhydris polylepis* (Homalopsinae). *Animal Behaviour* 68:1313-1324.
- Thayer, G. W., D. R. Colby, and W. F. Hettler, Jr. 1987. Utilization of the red mangrove prop root habitat by fishes in south Florida. *Marine Ecology Progress Series* 35:25-38.
- Turnbull, A. L. 1973. Ecology of true spiders (Araneomorphae). *Annual Review of Entomology* 18:305-348.
- Utne, A. C. W. 1997. The effect of turbidity and illumination on the reaction distance and search time of the marine planktivore *Gobiusc ulus flavescens*. *Journal of Fish Biology* 50:926-938.
- Webb, J. K., B. W. Brook, and R. Shine. 2003. Does foraging mode influence life history traits? A comparative study of growth, maturation and survival of two species of sympatric snakes from south-eastern Australia. *Austral Ecology* 28:601-610.
- Welsh, H. H., Jr, and A. J. Lind. 2000. Evidence of lingual-luring by an aquatic snake. *Journal of Herpetology* 34:67-74.
- Woodward, G., and A. G. Hildrew. 2002. Differential vulnerability of prey to an invading top predator: integrating field surveys and laboratory experiments. *Ecological Entomology* 27:732-744.

Appendix

Table 3. 1. Results of statistical analyses of five measures of activity within the test arena compared among the three different treatments in Experiment II. Subjects were 24 mangrove saltmarsh snakes (*Nerodia clarkii compressicauda*) observed in the presence of three guppies (*Poecilia reticulata*) at three simulated prop-root density levels (0 m⁻², 30 m⁻², and 60 m⁻²). Values in bold indicate statistically significant differences among the three treatments at the 0.05 level.

RVs	Rptd. Meas. ANOVA, univariate		Hotelling's Trace	
	<i>F</i> _{2,46}	<i>p</i>	<i>F</i> _{2,22}	<i>P</i>
Movements per Minute (MPM)	0.490	0.616	0.424	0.659
Pct Time Spent Moving (PTM)	1.766	0.182	1.533	0.238
PTM on Land	2.793	0.89	1.699	0.206
PTM at Shoreline	0.359	0.700	0.577	0.570
PTM in Water	4.478	0.017	8.034	0.002

Table 3. 2 Results of statistical analyses comparing time spent in the different parts of the test arena among the different simulated prop root densities in Experiment II. Subjects were 24 mangrove saltmarsh snakes (*Nerodia clarkii compressicauda*) observed in the presence of three guppies (*Poecilia reticulata*) at three prop-root density levels (0 m⁻², 30 m⁻², and 60 m⁻²). Values in bold indicate statistically significant differences among the three treatments at the 0.05 level.

RVs	Rptd. Meas. ANOVA, univariate		Hotelling's Trace	
	<i>F</i> _{2,46}	<i>p</i>	<i>F</i> _{2,22}	<i>p</i>
Percent of Time Spent on Land	2.807	0.087	1.973	0.163
Percent of Time Spent at Shore	1.066	0.353	0.808	0.458
Percent of Time Spent in Water	2.942	0.083	7.97	0.002
Mean Duration of Water Visits	2.376	0.122	5.535	0.011

Table 3. 3 Results of statistical analyses of measures related to interactions between 24 mangrove saltmarsh snakes (*Nerodia clarkii compressicauda*) and guppies (*Poecilia reticulata*) at three prop-root density levels (0 m⁻², 30 m⁻², and 60 m⁻²) in Experiment II. No statistically significant differences were revealed in the analyses.

RVs	Rptd. Meas. ANOVA, univariate		Hotelling's Trace	
	$F_{2,46}$	p	$F_{2,22}$	p
Number of 6-cm Encounters	1.406	0.255	1.140	0.338
Number of LTFs	1.187	0.314	1.146	0.336
Number of Attacks	0.330	0.721	0.347	0.711
Number of Captures	1.331	0.274	1.20	0.320

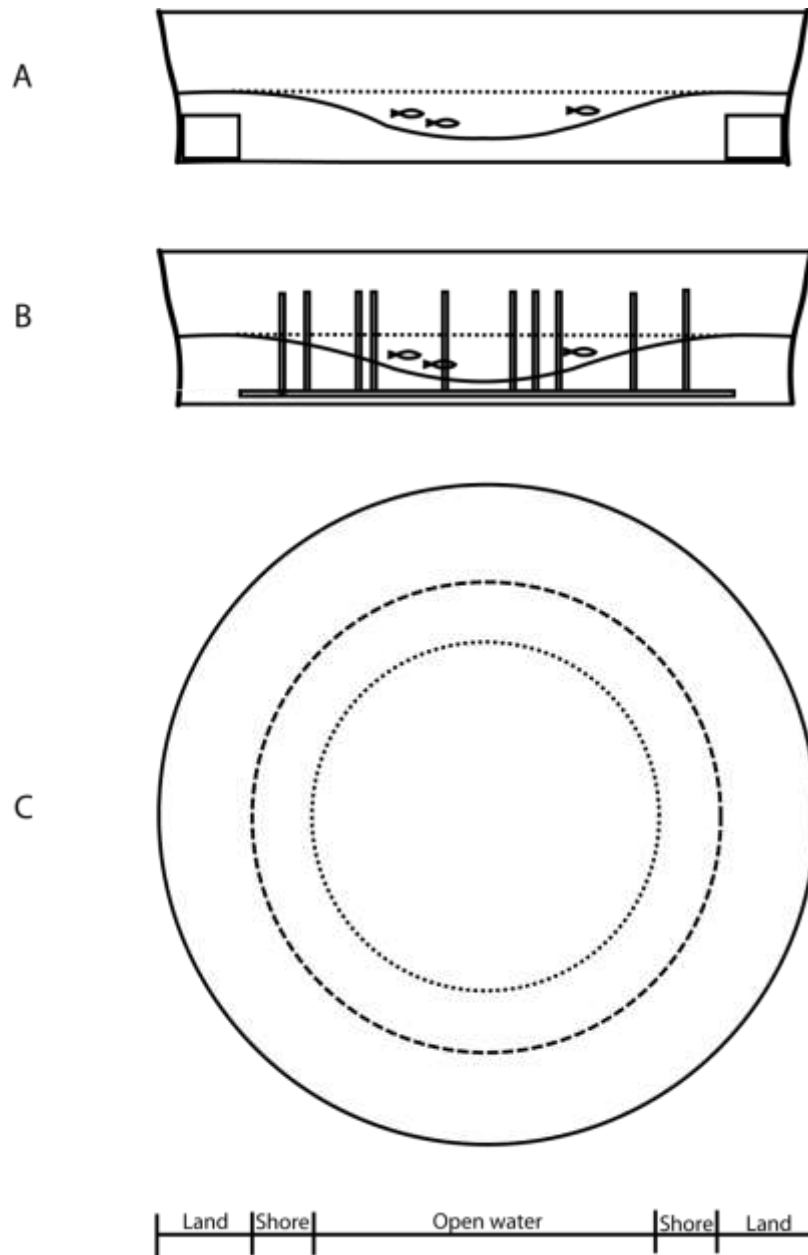

Figure 3. 1. Cartoon of the test arena used for experiments examining the effects of prey density (A) and habitat structural density (B) on foraging behaviour of mangrove saltmarsh snakes (*Nerodia clarkii compressicauda*) in Experiments I and II, respectively. The top-down view (C) and legend indicate the approximate positions of land, shore, and open water areas. Not drawn to scale. See text for dimensions.

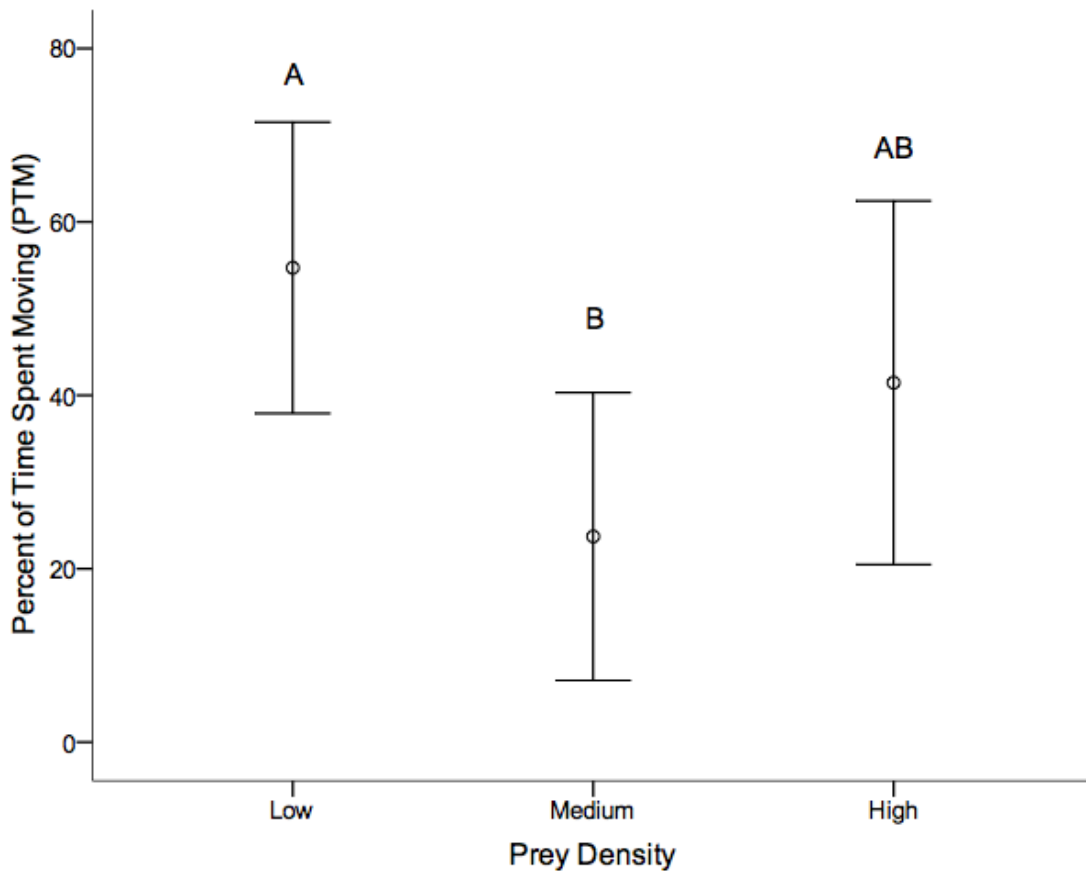

Figure 3. 2. Percent of time spent moving (PTM; mean \pm 95% CI) by mangrove saltmarsh snakes (*Nerodia clarkii compressicauda*) in the presence of prey guppies (*Poecilia reticulata*) at three different levels of prey density (Low = 2.6 m⁻²; Medium = 13 m⁻²; High = 65 m⁻²) in Experiment I. Means that do not share superscribed letters are significantly different from each other.

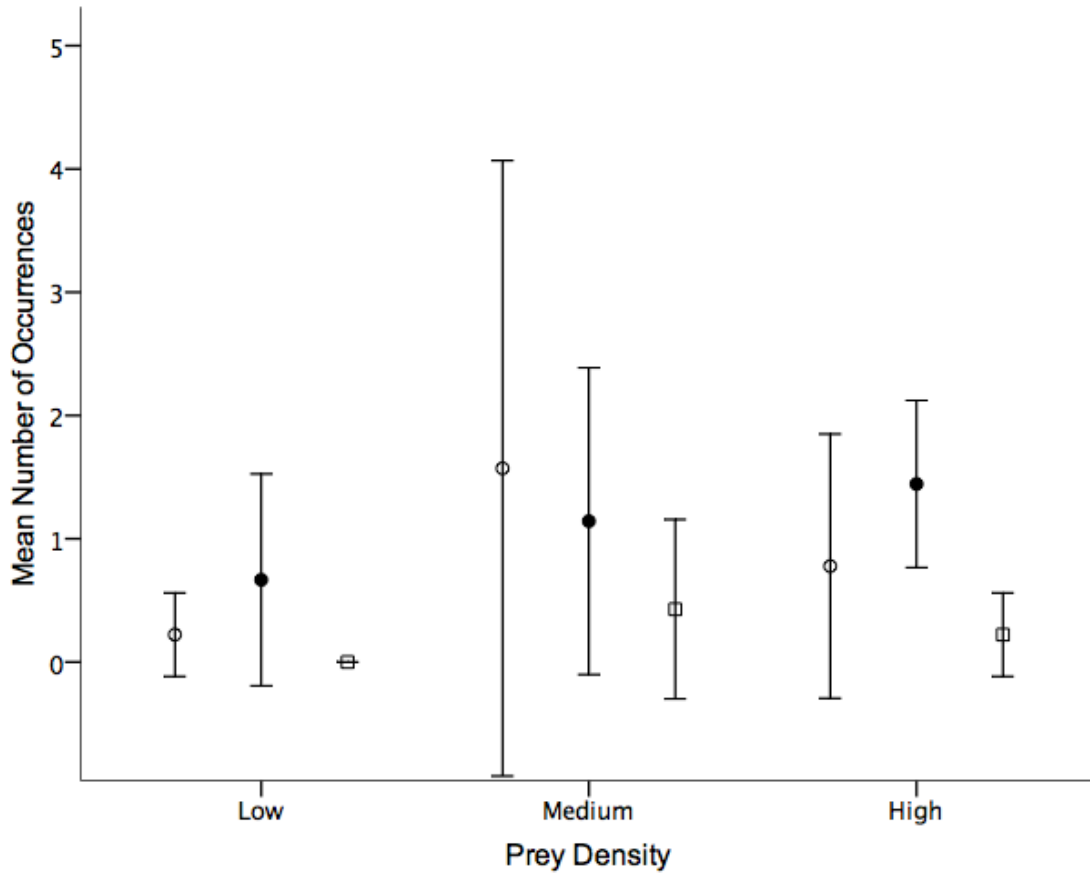

Figure 3. 3. Mean (\pm 95% CI) number of luring tongue flicks (open circles), attacks (closed circles), and captures (open squares) by mangrove saltmarsh snakes (*Nerodia clarkii compressicauda*) in the presence of prey guppies (*Poecilia reticulata*) at three different levels of prey density (Low = 2.6 m⁻²; Medium = 13 m⁻²; High = 65 m⁻²) in Experiment I.

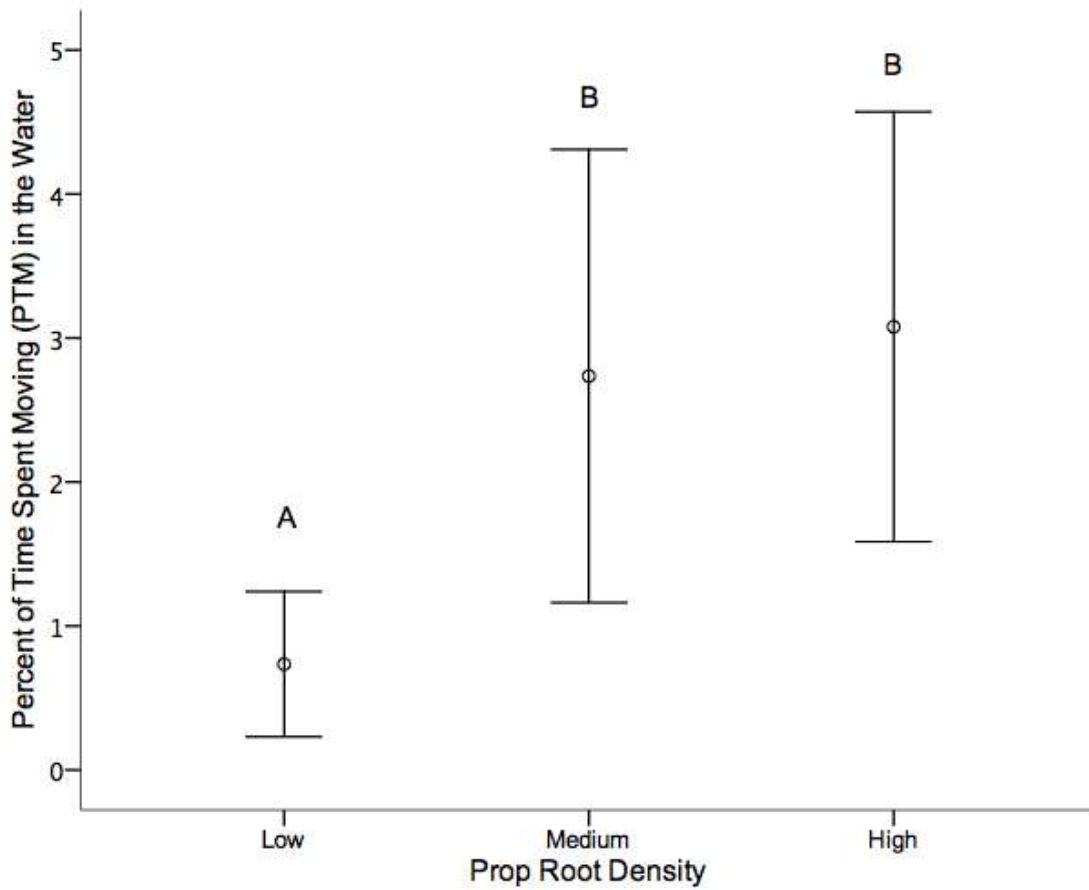

Figure 3. 4. Percent of time spent moving (PTM; mean \pm 95% CI) in open water by 24 mangrove saltmarsh snakes (*Nerodia clarkii compressicauda*) observed in the presence of three guppies (*Poecilia reticulata*) at three prop-root density levels (0 m^{-2} , 30 m^{-2} , and 60 m^{-2}) in Experiment II. Means that do not share superscribed letters are significantly different from each other.

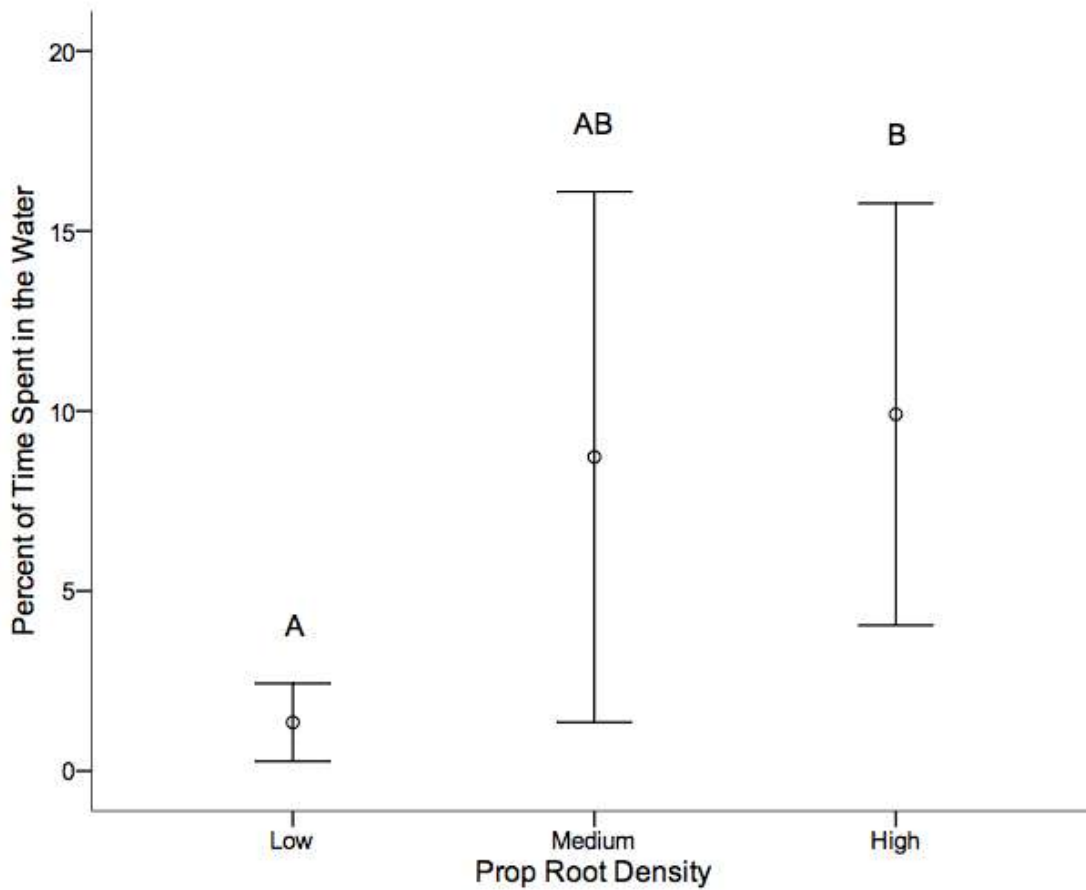

Figure 3. 5. Percent of time spent in open water (mean \pm 95% CI) among three levels of habitat structural complexity. Subjects were 24 mangrove saltmarsh snakes (*Nerodia clarkii compressicauda*) observed in the presence of three guppies (*Poecilia reticulata*) at three prop-root density levels (0 m^{-2} , 30 m^{-2} , and 60 m^{-2}) in Experiment II. Means that do not share superscribed letters are significantly different from each other.

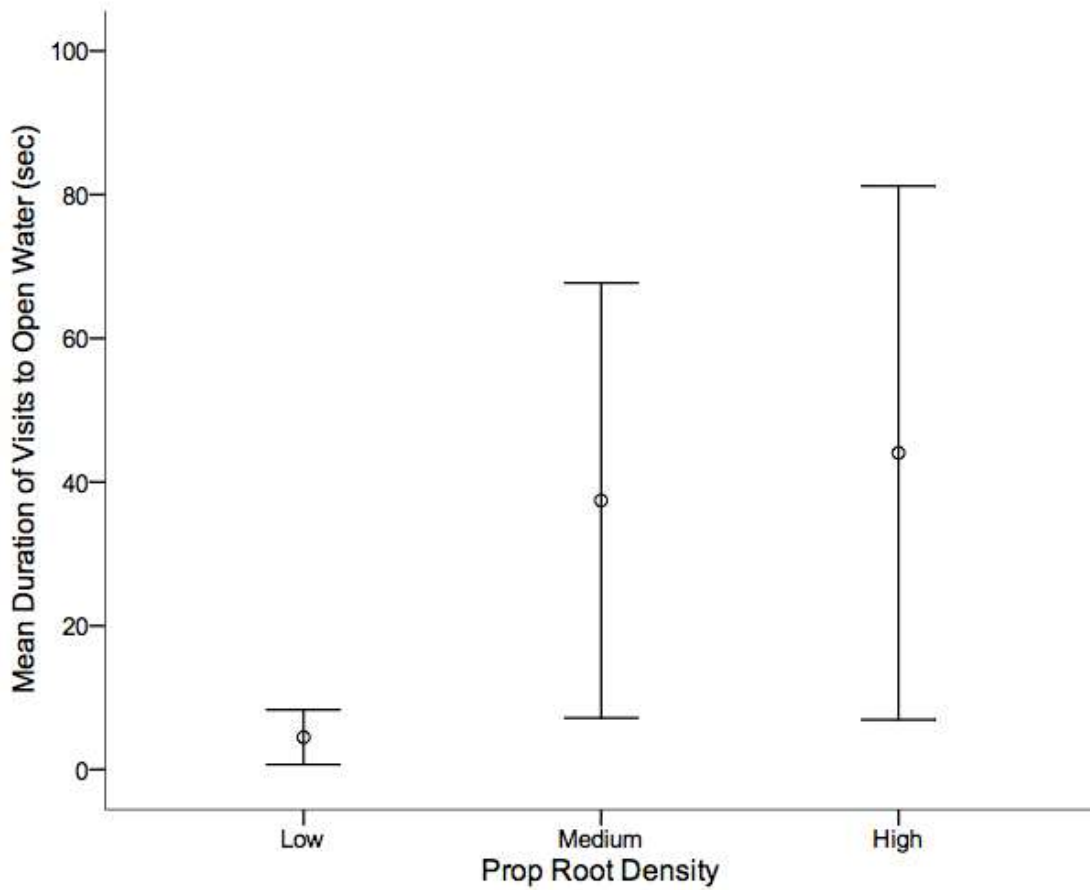

Figure 3. 6. Mean (\pm 95% CI) duration of visits to open water among three levels of habitat structural complexity. Subjects were 24 mangrove saltmarsh snakes (*Nerodia clarkii compressicauda*) observed in the presence of three guppies (*Poecilia reticulata*) at three prop-root density levels (0 m^{-2} , 30 m^{-2} , and 60 m^{-2}) in Experiment II.

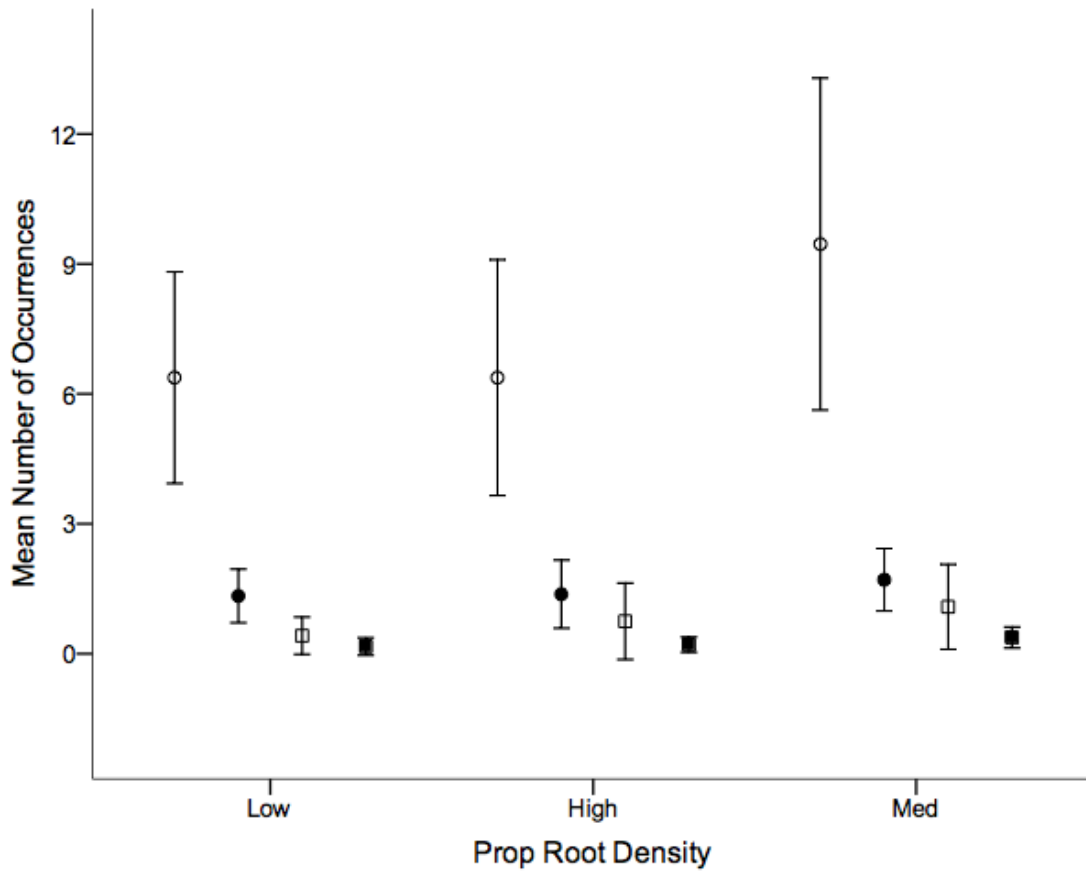

Figure 3. 7. Numbers (mean \pm 95% CI) of encounters (within 6 cm; open circles), attacks (closed circles), luring tongue flicks (open squares), and captures (closed squares) involving individual mangrove saltmarsh snakes (*Nerodia clarkii compressicauda*; $N = 24$) and three guppies (*Poecilia reticulata*) at three prop-root density levels (Low, 0 m^{-2} ; Medium, 30 m^{-2} ; and High, 60 m^{-2}) in Experiment II.

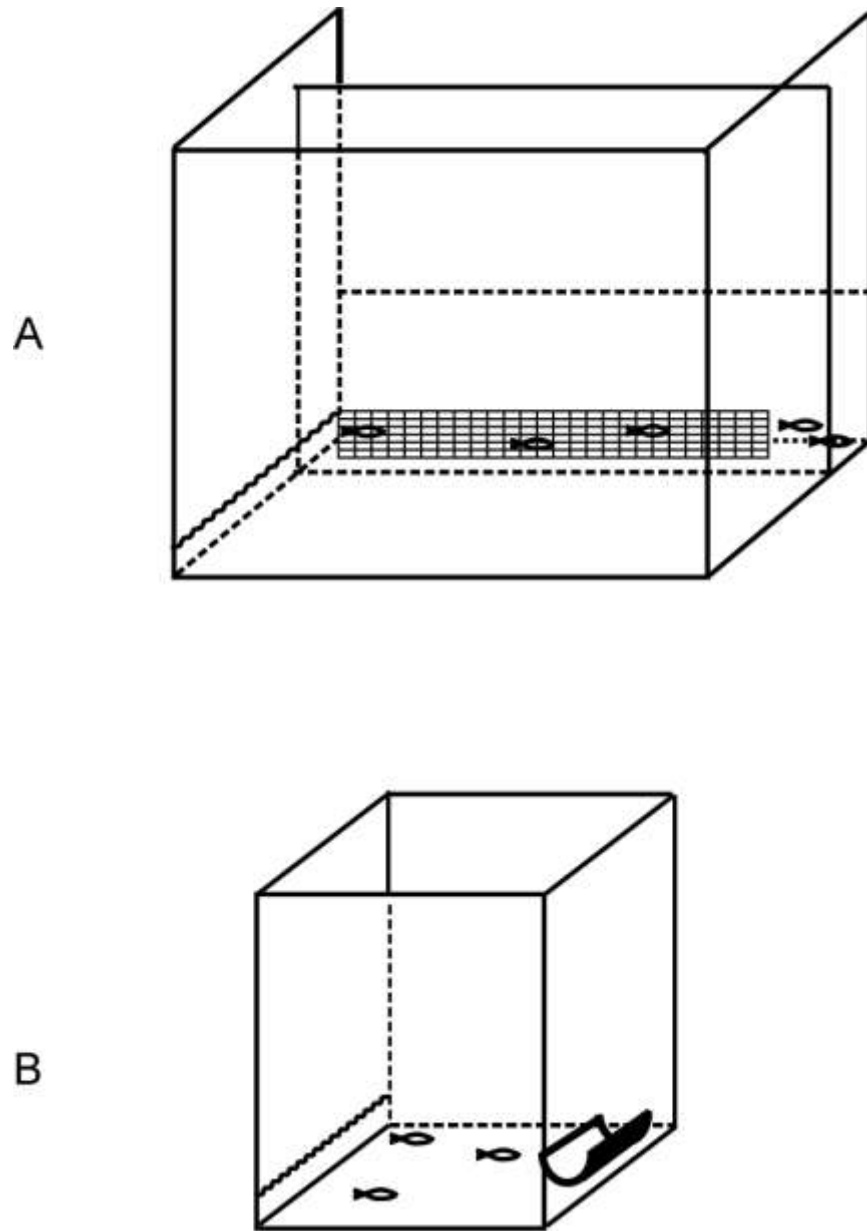

Figure 3. 8. Cartoon of the test arenas used in Experiment III for experiments examining the effects of light intensity on foraging behaviour of mangrove saltmarsh snakes (*Nerodia clarkii compressicauda*). Not drawn to scale. See text for dimensions.

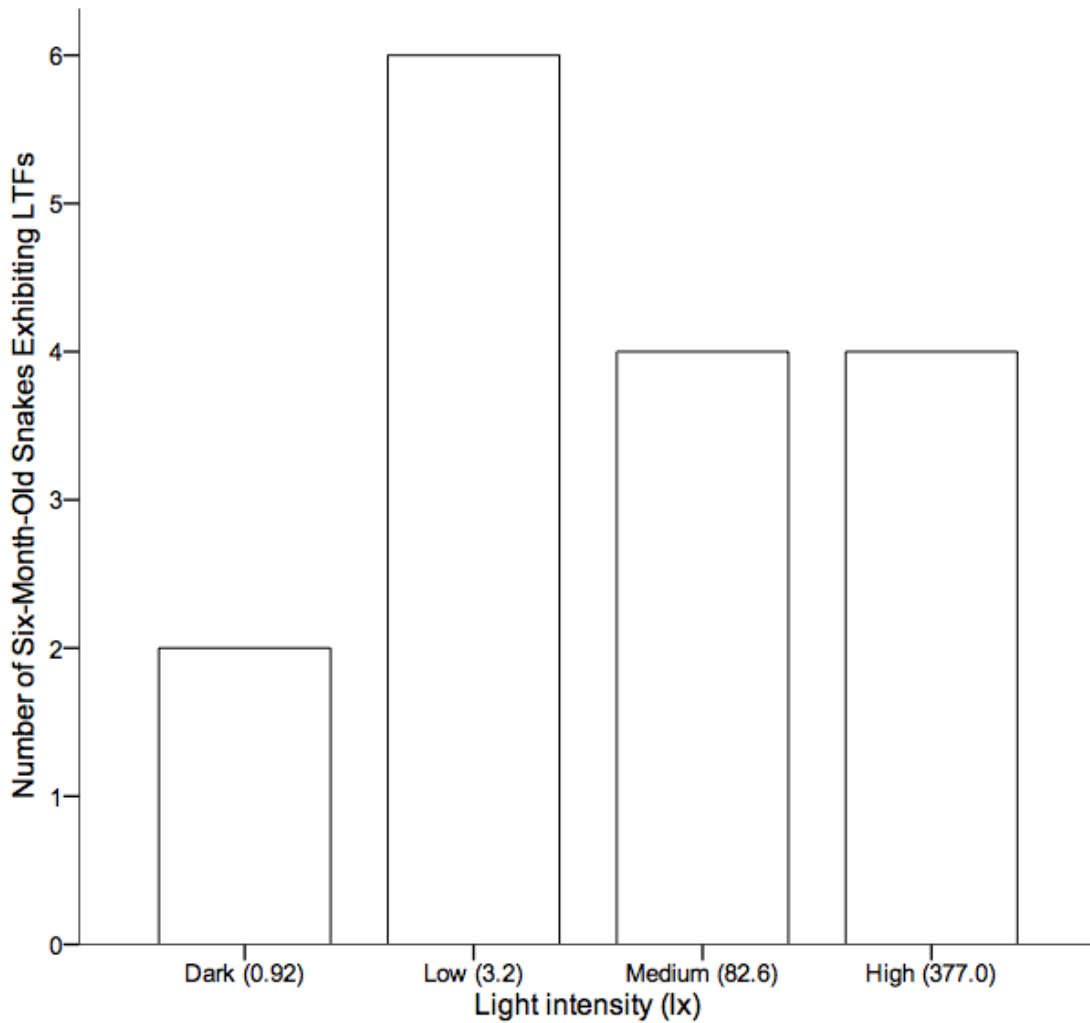

Figure 3. 9. Number of six-month-old mangrove saltmarsh snakes (N = 9) exhibiting luring tongue flicks (LTFs) in the presence of fish prey at each of four different light intensities in Experiment III.

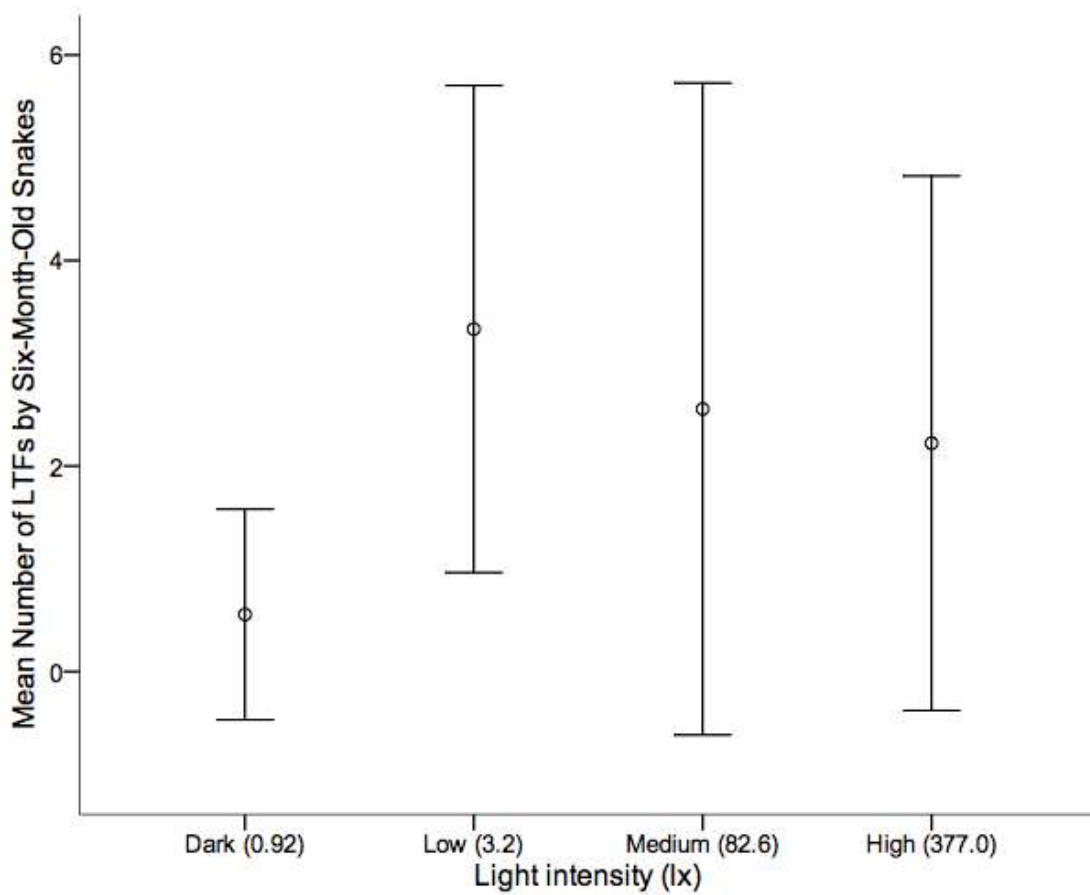

Figure 3. 10. Mean (\pm 95% CI) number of luring tongue flicks (LTFs) exhibited by six-month-old mangrove saltmarsh snakes ($N = 9$) in the presence of fish prey at each of four different light intensities in Experiment III.

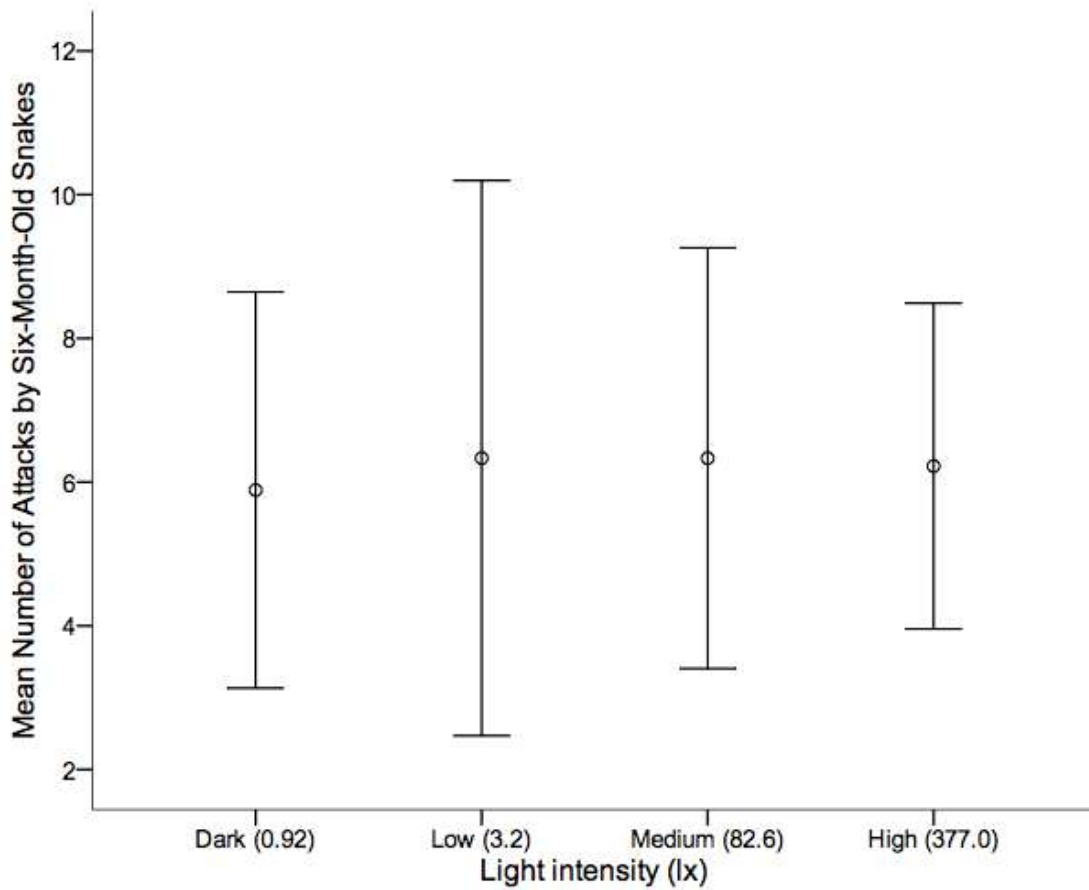

Figure 3. 11. Mean (\pm 95% CI) number of attacks exhibited by six-month-old mangrove saltmarsh snakes ($N = 9$) in the presence of fish prey at each of four different light intensities in Experiment III.

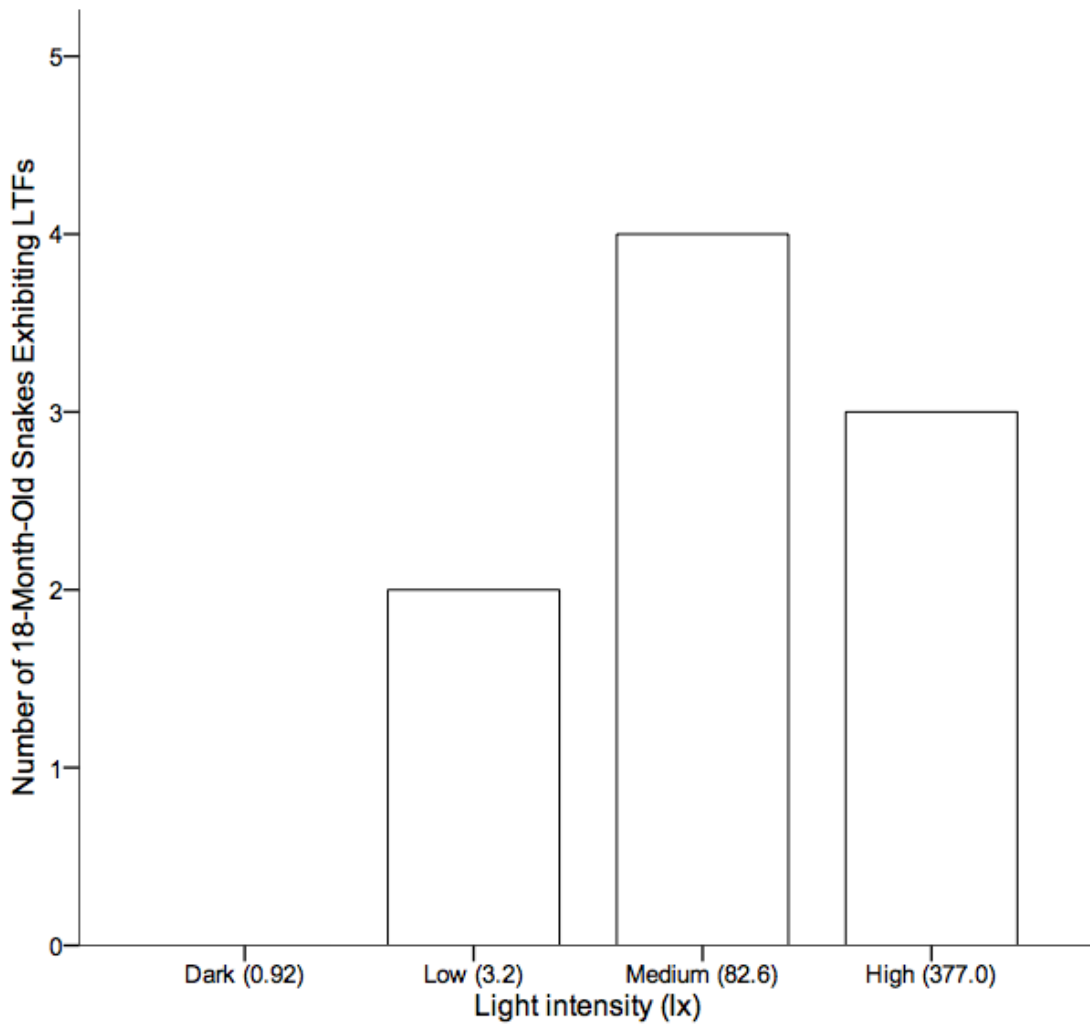

Figure 3. 12. Number of 18-month-old mangrove saltmarsh snakes (N = 15) exhibiting luring tongue flicks (LTFs) in the presence of fish prey at each of four different light intensities in Experiment III.

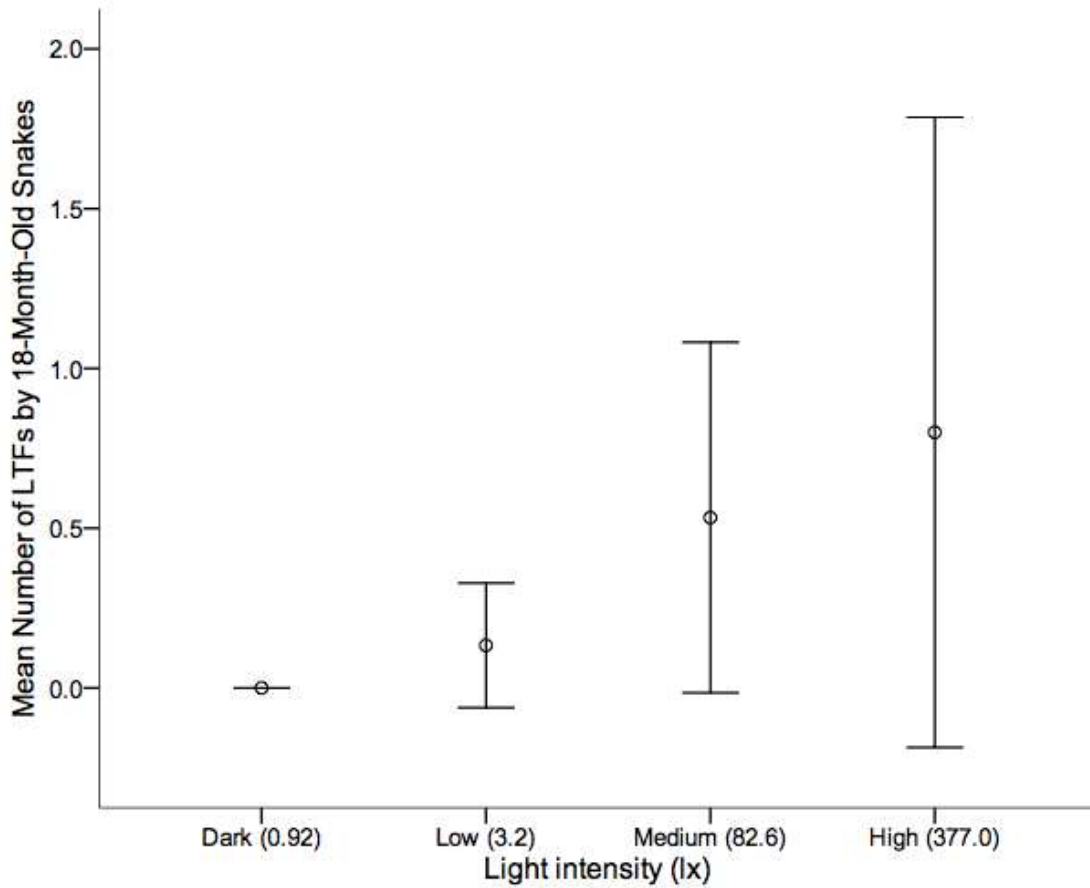

Figure 3. 13. Mean (\pm 95% CI) number of luring tongue flicks (LTFs) exhibited by 18-month-old mangrove saltmarsh snakes (N = 15) in the presence of fish prey at each of four different light intensities in Experiment III.

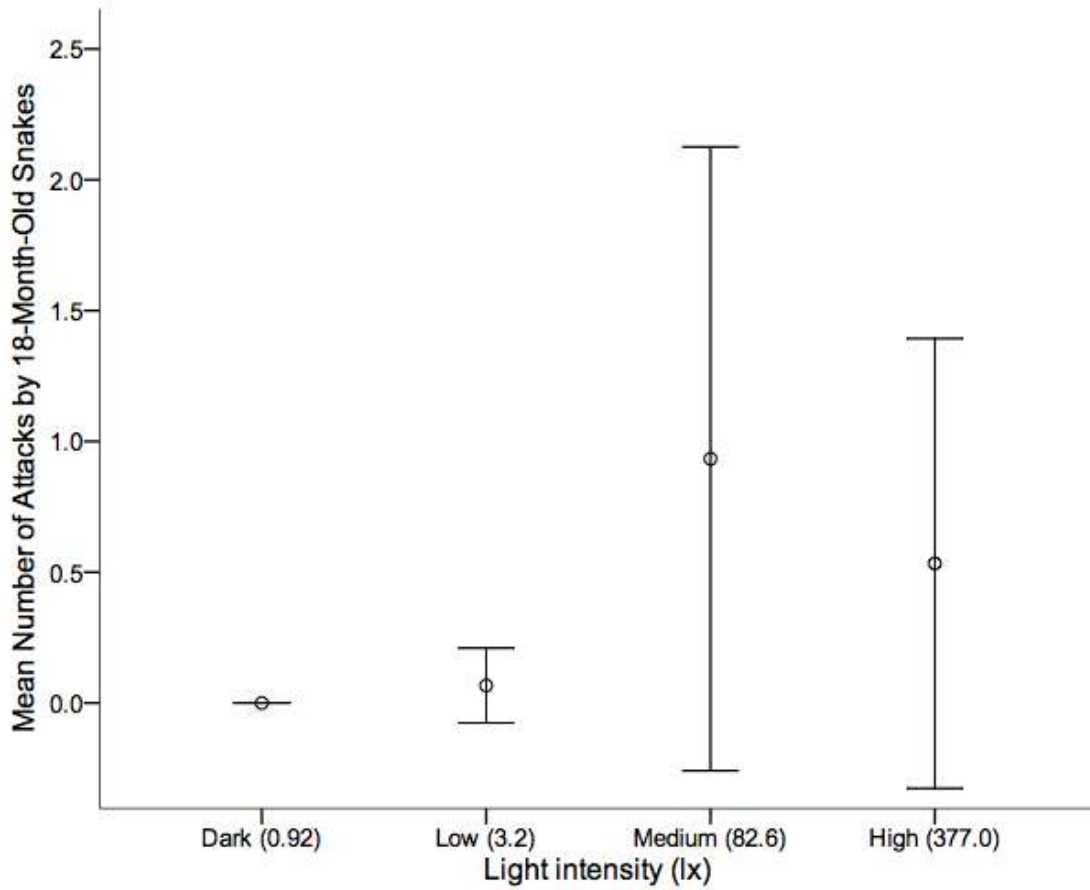

Figure 3. 14. Mean (\pm 95% CI) number of attacks exhibited by 18-month-old mangrove saltmarsh snakes (N = 15) in the presence of fish prey at each of four different light intensities in Experiment III.

CONCLUSION

Mangrove saltmarsh snakes are moderately active predators that employ a mixed foraging strategy, varying their use of alternative tactics when environmental characteristics change. One of the tactics they use is a unique form of predatory luring known as lingual luring. By extending their tongue and keeping it out for long periods, they aim to attract fish prey close enough to permit capture. The luring behavior is exhibited only when there is evidence of the presence of prey fish, and it clearly functions to attract them. The mixed foraging strategy of mangrove saltmarsh snakes is affected by a number of other ecological variables. Alterations in prey density brought about changes in the activity level of these snakes, which may also have been connected to transitions between different phases in the predation cycle. Snakes were more active when fewer prey were present, and a large part of this activity occurred on the land area, where they may have switched to the search phase from the pursuit phase. A similar transition may have occurred with changes in habitat structure, which were accompanied by switches in foraging location. Subjects spent more time in the water when there was greater structural density, and this may have been related to several things, including changes in the visibility of prey to the snakes as well as the snakes' own perception of danger. Among ecological variables other than prey-related stimuli, only light intensity affected the frequency of lingual luring, indicating that one of the few stable requirements for the use of this tactic is a modicum of available light. As such, lingual luring by mangrove saltmarsh snakes appears to present a visual cue to the prey fish involved.

VITA

Kerry Hansknecht received his undergraduate degree in biology at George Mason University, where he developed his interest in reptiles, especially watersnakes. His graduate career began at Central Michigan University, where he was able to spend countless hours watching watersnakes forage in Lake Michigan, one of the most enjoyable experiences of his professional career. He has continued to study watersnakes at the University of Tennessee, and moving on to a university position in the southeastern US, he should have no trouble finding more watersnakes to study.