



4-1-1999

SP435C No-till Establishment of Forage Crops

The University of Tennessee Agricultural Extension Service

Follow this and additional works at: http://trace.tennessee.edu/utk_agexfora

Recommended Citation

"SP435C No-till Establishment of Forage Crops," The University of Tennessee Agricultural Extension Service, SP435C-5M-4/99 E12-2015-00-261-99, http://trace.tennessee.edu/utk_agexfora/9

The publications in this collection represent the historical publishing record of the UT Agricultural Experiment Station and do not necessarily reflect current scientific knowledge or recommendations. Current information about UT Ag Research can be found at the [UT Ag Research website](#).

This Forages is brought to you for free and open access by the UT Extension Publications at Trace: Tennessee Research and Creative Exchange. It has been accepted for inclusion in Forages by an authorized administrator of Trace: Tennessee Research and Creative Exchange. For more information, please contact trace@utk.edu.



No-till Establishment of Forage Crops

*Gary Bates, Associate Professor, Plant and Soil Science
H. Paul Denton, Professor, Plant and Soil Science*

Agriculture has changed in many ways during the last 50 years. One of the greatest changes has been the use of no-till planting methods. When no-till planting is mentioned, most people usually think of crops such as corn, soybeans and cotton. The problem of soil erosion with conventional row-crop production has been significantly decreased by using herbicides to kill a cover crop and planting without tillage. Though often overlooked, no-till technology is also well-suited to be used in forage crop establishment.

Why Use No-till?

Many of the pastures in Tennessee were planted to permanent pastures because they were too steep to conventionally plant to corn or soybeans. The potential for soil erosion was so great that a perennial plant had to be used to prevent yearly seedbed preparation and the soil erosion that was inevitable with crop production on these slopes. The main advantage to no-till planting is to conserve soil and decrease erosion.

No-till planting has several other advantages. Planting is able to occur soon after a rain using no-till, while the soil must be allowed to dry before disking when conventional planting is used. After planting, the soil retains moisture

longer when no-till is used, because the soil is not directly exposed to the sun. Cost comparisons between conventional and no-till planting generally show the expenses for both to be similar. No-till plantings require less fuel and labor than conventional planting, but require a chemical kill of the existing vegetation.

Characteristics Needed in No-Till Drills

Good no-till drills need to be able to place seed at the right depth, at the right rate and in good contact with soil. They need to do this across a wide range of soil-water contents, soil types, slopes and residue cover. Listed below are some characteristics to consider in choosing or using a no-till drill.

Weight — A no-till drill needs enough weight to let coulters and seed openers penetrate firm soil, allow press wheels to close the seed furrow and keep drive wheels or coulters in good contact with the ground. Depending on soil-water content, depth of planting and the setup of the drill, this may require 300 to 600 pounds per foot of width. Because weight needs vary, most drills have weight brackets to add weights or barrels that can be filled with water.

Coulters — Many drills use coulters to cut through residue in front of seed-furrow openers. In general, narrow coulters less than 1 inch wide disturb less residue, require less weight and work better across a wider range of conditions than wide-fluted coulters. Either narrow-ripple or smooth-edge ripple (bubble) coulters work well on drills. Coulters should be as close to openers as possible for better tracking on hills. Generally, coulters should be run at the depth of seeding or slightly deeper. Some drills use offset double-disk openers or angled, single-disk openers instead of coulters. These drills require less weight to penetrate the soil and have fewer moving parts. Disk openers wear out quicker on these drills, and the coulters may be useful in heavy residue.

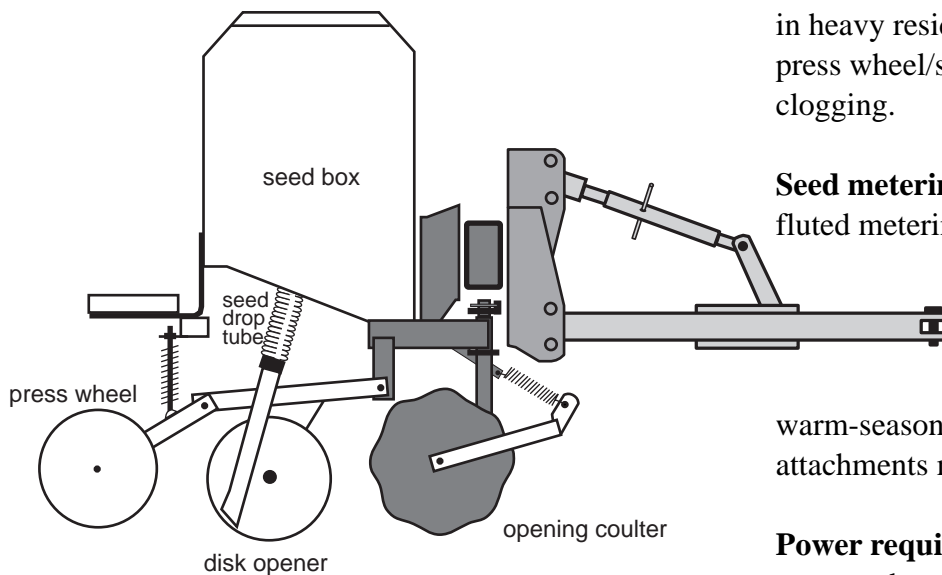

Seed furrow opener — Double- or single-disk openers give more consistent depth of seeding and handle heavy residue better than hoe or shovel openers. They are particularly better for shallow planting of small seed, such as alfalfa and clovers.

Depth control — Seeding depth is usually controlled by the press wheels or by depth gauge wheels mounted by the seed openers. Some drills rely on coulters depth to set seeding depth, but this

method will not give as consistent results. In choosing a drill, it is important that seeding depth be easily adjustable and that there be a simple, fast method to set all units at the same depth.

Press wheels — Press wheels cover the seed, firm the soil and control seeding depth on many planters. Generally, either single 2-inch press wheels or two narrow press wheels in a V-shaped configuration work well on no-till drills. Single, narrow press wheels (1 inch wide) will not control depth well in soft soils and should be used only if depth is controlled by gauge wheels. Press wheels wider than 2 inches will not close the seed furrow in no-till unless they have ribs on either side of the furrow. The angled, V-shaped press wheels work well on hard ground, but may clog in heavy residue like corn stubble. Staggering the press wheel/seed opener units helps reduce clogging.

Seed metering — Most drills have internally fluted metering mechanisms that are easy to adjust and are suitable for a wide range of seeds. However, for small-seeded legumes or light, fluffy seeds like some of the warm-season prairie grasses, special seed box attachments may be needed.

Power requirements — Pull-type drills need five to seven horsepower per foot of width. Mounted drills need 10 to 15 horsepower per foot for adequate lift capacity.

Tracking — Proper tracking, with the seed opener and press wheels following in line behind the coulters, is often a problem on hilly ground or in turns. Drills that have the coulters as close as possible to the openers or that do not need leading coulters have less problems with tracking. Wider coulters help by tilling a wider zone, but they require more weight.

Maintenance and operation — If you own a no-till drill, be sure to follow recommended maintenance practices. Be familiar with operating procedures as described in the owner's manual. Always inspect the drill well before use and replace broken or worn parts that will affect drill performance. Many forage producers rent drills. The age, type and maintenance of these units will vary greatly. If you rent, be sure you understand how to adjust the seeding rate, how to change the seeding depth, how the weight and ballasting system works, and what the horsepower and hydraulic requirements of the drill are. Inspect the drill when you pick it up for worn, broken or missing parts. Be sure that the seed-metering mechanism, coulters and press wheels are adequate for your crop and conditions. Before beginning to plant, take time to adjust coulters settings and seeding depth, and to calibrate the drill. More tips on calibration and use can be found in the calibration section below.

Steps for Successful No-till Establishment of Forages

Research and farmer experience have shown that most forage crops can be planted using no-till methods. Forage species may differ in many of their characteristics (seedling vigor, tolerance to shading, etc.), but the basic principles for successful no-till establishment are the same for all forage crops. Following are a few important details to be successful in obtaining a stand using no-till.

(1) Fertilize according to soil test.

Conditions in the field to be planted need to be manipulated so the environment created favors the forage to be planted. The first step in creating a favorable environment is to provide the nutrients needed for seed germination and seedling growth. An optimum pH, plus adequate nitrogen, potash and phosphate are required by the plant. The more acid the soil, the less of these

nutrients are available and the more conditions favor weeds over forage. Lime and fertilizer applications should be based on soil test results, and can be applied to the soil surface. Even though the lime and fertilizer are not incorporated in the soil, they will still be effective. Fertilizer can be applied at planting, while lime needs to be applied as far ahead of planting as possible. This is especially important for sensitive crops such as alfalfa. For sensitive crops, if the pH is below 6.0, lime should be applied 6-12 months prior to seeding.

(2) Plant at the proper time. Seeding date is very important for successful establishment of forages. All forages have specific environmental conditions that result in their peak production. For instance, tall fescue is the most productive during the spring and fall, when temperatures are relatively cool and moisture is plentiful. Hot, dry conditions during the summer cause a somewhat dormant period for tall fescue. The response that a plant has to environmental conditions will be even more dramatic when it is a seedling. Plants need to be seeded when temperature, day length and moisture favor the young seedlings. Recommended seeding dates for several forage crops are listed in Table 1.

Table 1. Recommended planting rates and dates for several forage crops.

crop	seeding rate (lb/acre)	seeding date
tall fescue	15	Aug 15 - Oct 1* Feb 20 - April 1
orchardgrass	15	Aug 15 - Oct 1* Feb 20 - April 1
timothy	9	Aug 15 - Oct 1* Feb 20 - April 1
wheat	90	Sept 1 - Nov 10
rye	120	Aug 15 - Oct 15
annual ryegrass	20	Aug 15 - Oct 15
bermudagrass	6 - 10	April 15 - July 1
pearl millet	10 - 15	May 1 - July 15
sorghum X sudangrass hybrid	30	April 20 - July 1
alfalfa	15 - 20	Aug 15 - Sept 15* March 1 - May 1
red clover	8	Feb 15 - April 1
white clover	2	Feb 15 - April 1
annual lespedeza	25 - 40	March 15 - April 15
* Fall planting is usually the most successful for tall fescue, orchardgrass and timothy. If possible, no-till alfalfa seedings should be made in spring to avoid sclerotinia crown rot.		

(3) Plant the proper amount of seed. The maximum production from a hay field or pasture can only be achieved if enough forage plants are present to provide the yield. If only a half a stand of alfalfa or tall fescue is present, no amount of fertilizer can be added to produce the maximum yield. Because of this, it is important to plant enough seed to ensure a full stand. Most producers who use no-till for forage plantings do not own their own drill. Most no-till drills are rented from local farm-supply companies. Producers are fortunate to have access to no-till drills without having to purchase one; however, these drills typically see many hours of use and are not always in the best shape. It is important to check the seed flow from these drills to be sure that the proper amount of seed is being planted.

The calibration charts on these drills are usually correct when drills are new, but as they get older and parts wear, seeding rates may be significantly higher or lower than recommended rates. Spending a few minutes before planting can prevent all of the seed being placed on a small portion of the field, or having to run over the field twice because the drill wasn't putting out enough seed. Recommended seeding rates for various forage crops are also listed in Table 1.

Calibrating a drill is nothing more than determining how much seed is being released per acre at a given setting. To calibrate a drill, set the seed flow rate for the drill according to its calibration chart guidelines. Mark a 100-foot length to use for catching seed. Load the seed and pull the drill for several feet until seeds begin to

flow. Then tape a bag on to each of the holes that let seed fall. Once the bags are attached, pull the drill over the 100-foot marked area. Weigh the amount of seed released over the 100-foot area. Seeding rate in pounds per acre can be determined by the following formula:

$$\text{Seeding rate (lb/acre)} = \text{seed released (in lb)} * \frac{43560 \text{ sq ft per acre}}{100 \text{ ft} * \text{drill width (in ft)}}$$

Be sure to use the amount of seed released in pounds. If it is measured using a gram scale, convert the measurement to pounds by dividing by 454.

(4) Plant when moisture is available. Water is the most critical nutrient for plant survival. Without nitrogen, potash or phosphate, a plant might not be very productive, but it should still be able to survive. A lack of water will result in the slow death of a plant. When using a no-till drill to plant a forage, you must have adequate soil moisture available for success. You are depending on the drill to slice open a furrow in the soil, drop the seed and then press the soil together for good soil-to-seed contact. If the soil is dry, it may be too hard for the disc openers to get into the soil, and soil-to-seed contact will be poor. A poor stand may result, because seed was dropped on top of the ground instead of being placed in the ground.

A second reason adequate moisture is needed

for successful no-till is because moisture is needed for the seed to germinate. Some no-till drills are heavy enough so they can penetrate the soil no matter how dry and hard it is. If the soil is dry, however, the seed will not germinate until rain comes. Often there is just enough moisture

for the seed to germinate and begin to grow, but before the root system can get established, the seedling dries up and dies from moisture stress. Don't be lulled into thinking that just because the drill is getting into the ground that all problems are solved. Without adequate moisture, seedlings have no hope of getting established.

(5) Plant at the proper depth. A common error with no-till planting is placing seed too deep in the ground. The first few weeks of a seedling's life are the most difficult. When a seed germinates, it must push its way through the soil to the surface so it can receive sunlight. Once in the sun, it can produce its own energy. Until that happens, it must depend on energy stored in the seed to grow. The deeper a seed is planted, the more energy required for it to emerge from the soil. Some seeds are relatively large and should be planted deep. Other seeds are small, and have very little energy stored. These seed should be

Table 2. Recommended seeding depth for forage crops.

<i>crop</i>	<i>depth (inches)</i>
alfalfa	1/4 to 1/2
clovers	1/4 to 1/2
bermudagrass	1/4 to 1/2
tall fescue, orchardgrass, timothy, annual	1/4 to 1/2
ryegrass, small grains	
pearl millet	1/2 to 1 1/2
sorghum x sudangrass hybrid	1 to 2

planted very shallow. Table 2 gives recommended seeding depths for many forage crops.

No-till drills vary in the method used to control coulters seeding depth. Coulters depth on some drills can be adjusted by adding or removing weights to the drill. Some drills have a hydraulic mechanism that can be raised or lowered to adjust coulters depth. A variety of mechanisms are used to adjust disk opener depth. When the drill is being calibrated for seeding rate, several furrows should be checked to determine the depth the coulters is cutting into the ground and the depth of seed placement.

(6) Control weeds at planting. The purpose of no-till is to maintain cover on the area and decrease soil loss because of seedbed preparation. Successful no-till depends on killing all vegetation at planting, which will decrease competition for young seedlings. The two major chemicals used for burndown prior to planting are Roundup® and Gramoxone Extra®. Both herbicides are non-selective, which means they are active on all plants. Gramoxone Extra is a contact herbicide, meaning that it works by desiccating the green tissue it touches. Roundup, on the other hand, is systemic (absorbed by the plant and moves within the plant to roots, rhizomes, etc.). Because of this, Roundup will generally provide more thorough control of perennial weeds, although it takes longer to see its results. For recommendations concerning the specific herbicide to use, as well as rates and dates to spray, check with your local Extension office. It is important to do a good job with the burndown before planting. Competition from weeds can result in a partial or total failure of a no-till stand.

Conclusion

No-till plantings can be successful, as long as the proper procedures are followed. If a no-till seeding fails, the reason can usually be traced to one of the points listed above. Planning ahead for soil testing, drill calibration and weed control are critical steps. It is also important to use patience and wait for rain. Planting into a dry seedbed can cause the death of a stand. Preparation is the key to success in no-till plantings.



PRINTED ON RECYCLED PAPER

Precautionary Statement

To protect people and the environment, pesticides should be used safely. This is everyone's responsibility, especially the user. Read and follow label directions carefully before you buy, mix, apply, store, or dispose of a pesticide. According to laws regulating pesticides, they must be used only as directed by the label.

Pesticides recommended in this publication were registered for the prescribed uses when printed. Pesticide registrations are continuously being reviewed. Should registration of a recommended pesticide be canceled, it would no longer be recommended by The University of Tennessee.

Use of trade or brand names in this publication is for clarity and information; it does not imply approval of the product to the exclusion of others which may be of similar, suitable composition, nor does it guarantee or warrant the standard of the product.

SP435C-5M-4/99
E12-2015-00-261-99

A State Partner in the Cooperative Extension System

The Agricultural Extension Service offers its programs to all eligible persons regardless of race, color, national origin, sex, age, disability or veteran status and is an Equal Opportunity Employer. COOPERATIVE EXTENSION WORK IN AGRICULTURE AND HOME ECONOMICS. The University of Tennessee Institute of Agriculture, U.S. Department of Agriculture and county governments cooperating in furtherance of Acts of May 8 and June 30, 1914.

Agricultural Extension Service, Billy G. Hicks, Dean